



**AUSTRALIA'S  
BIGGEST RANGE OF 2 POST HOISTS**

# **Classic CL4500XH**

## **Installation/Owners Manual**

### **CONTENTS**

Product Features and Specifications .....1

Installation Requirement .....3

Steps of Installation .....5

Test Run .....20

Operation Instruction.....22

Maintenance Schedule .....23

Trouble Shooting .....24

Exploded View .....25

Lift Disposal .....33

**Classic CL4500XH**

Model	Lifting Capacity	Lifting Height	Lifting Time	Overall Height	Overall Width	With Between Columns	Minimum Pad Height	Motor
Classic CL4500XH	4500KG	2000~2290mm	64s	4035/4313mm	3666mm	3000mm	90mm	3.0HP

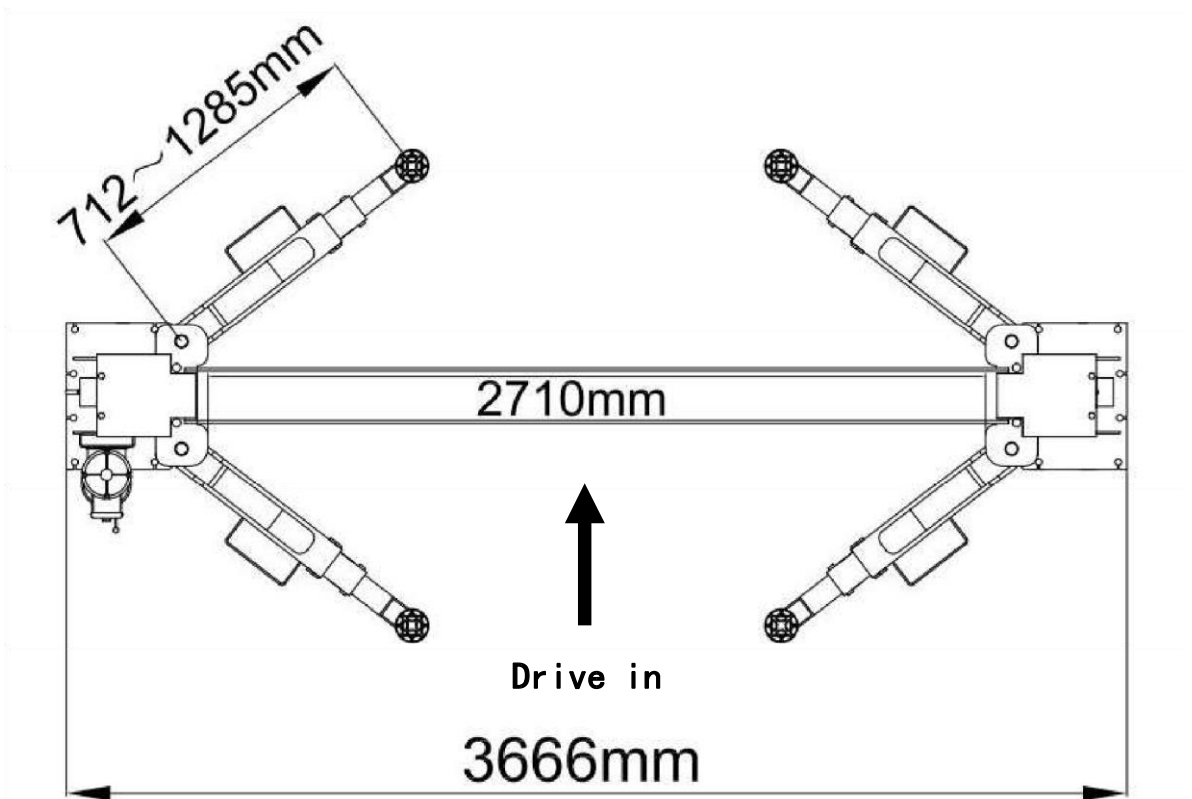

**Fig. 2**

**II. INSTALLATION REQUIREMENT**

**A. TOOLS REQUIRED**

- ✓ Rotary Hammer Drill (Φ19)



- ✓ Carpenter's Chalk



- ✓ Hammer



- ✓ Screw Sets



✓ Level Bar



✓ Tape Measure (7.5m)



✓ English Spanner (12")



✓ Pliers



✓ Ratchet Spanner With Socket (28#)



✓ Socket Head Wrench (3#, 6#)



✓ Wrench set

(10#, 13#, 14#, 15#, 17#, 19#, 24#, 27#)

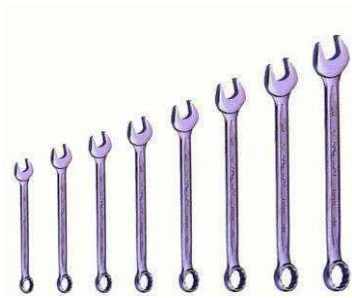

✓ Lock Wrench



**Fig. 3**

**B Equipment storage and installation requirements.**

**The equipment should be stored or installed in a shady, normal temperature, ventilated and dry place.**

**C.The equipment should be unload and transfer by forklift.**



**Fig.4**

#### D. SPECIFICATIONS OF CONCRETE (See Fig. 10)

Specifications of concrete must be adhered to the specification as following.

Failure to do so may result in lift and/or vehicle falling.

1. Concrete must be thickness **100mm** minimum and without reinforcing steel bars, and must be dried completely before the installation.
2. Concrete must be in good condition and must be of test strength 3,000psi (210kg/cm<sup>2</sup>) minimum.
3. Floors must be level without cracks.

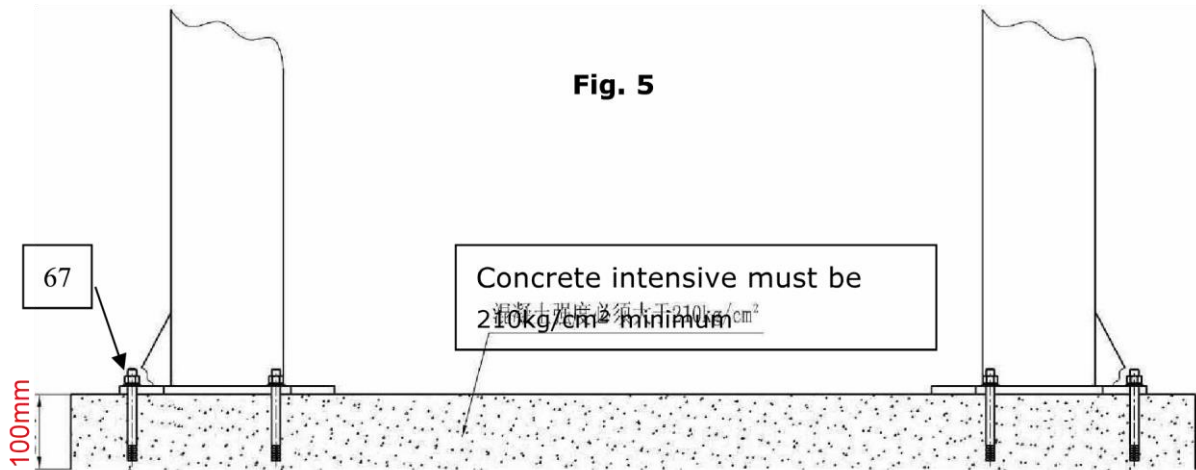

#### E. POWER SUPPLY

The electrical source must be 2.2KW minimum. The source cable size must be 2.5mm<sup>2</sup> and in good condition of contacting with floor.

### III. STEPS OF INSTALLATION

#### A. Location of Installation

Check and insure the installation location (concrete, layout, space size etc.) is suitable for lift installation.

**B.** Use a carpenter's chalk line to establish installation layout of base plate (See Fig. 6).

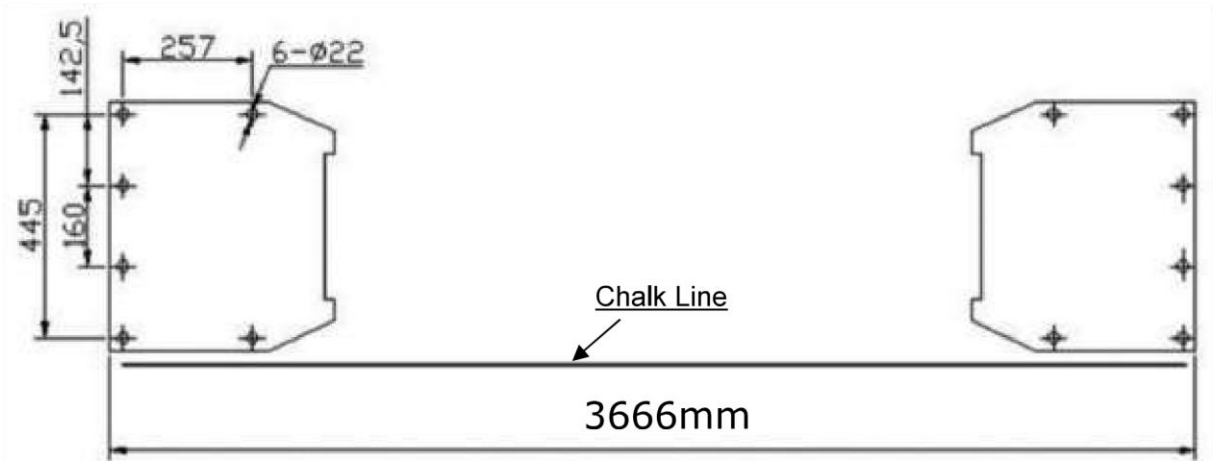

**Fig.6**

#### C. Check the parts before assembly

1. Packaged lift and hydraulic power unit (see Fig. 7)

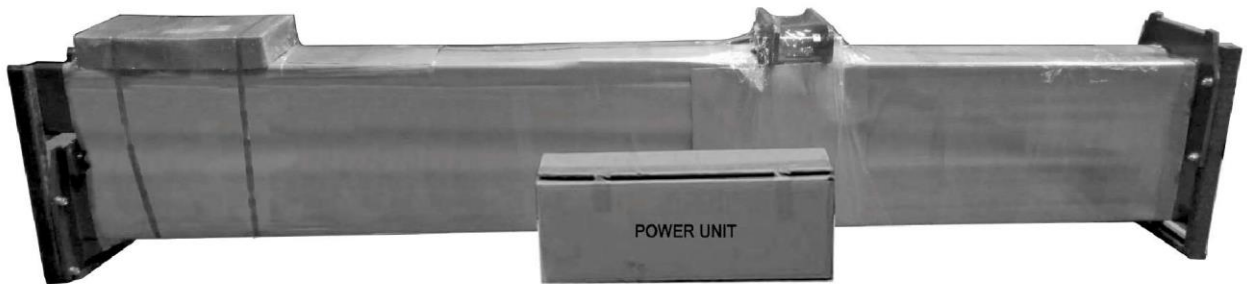
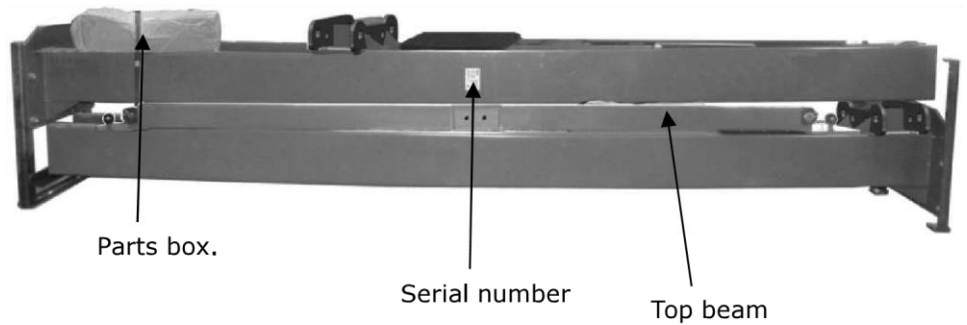

**Fig. 7**

2. Move the lift aside with a fork lift or hoist, and open the outer packing carefully , take off the parts from upper and inside the column, take out the parts box, check the parts according to the shipment parts list (See Fig. 8).



Shipment Parts



**Fig. 8**

3. Loosen the screws of the upper package stand, take off the upper column and remove the package stand.
4. Move aside the parts and check the parts according to the shipment parts list (See Fig. 9, 10).



**Fig. 9**

Parts in the shipment parts list

**40**



**Fig. 10**

Parts in the parts box (40)



5. Open the bag of parts and check the parts of the parts bag according to parts bag list (See Fig. 11).



**Fig. 11**

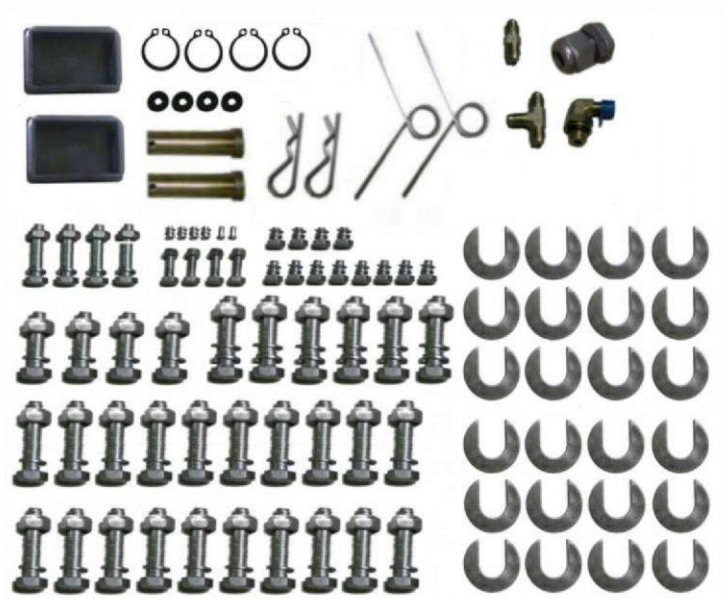

. o n

### D P sitio power side column

Lay down two columns on the installation site parallel, position the power side column according to the actual installation site. Usually, it is suggested to install power-side column on the right side of vehicles enter direction. (See Fig. 12).

This lift is designed with 2-section columns. Adjustable height according to the ceiling height and connecting the inner and extensions columns.

Ceiling height over 4343mm, can be both low setting/high setting,

Ceiling height between 4065-4343mm, only available low setting.

Minimum ceiling height: 4065mm

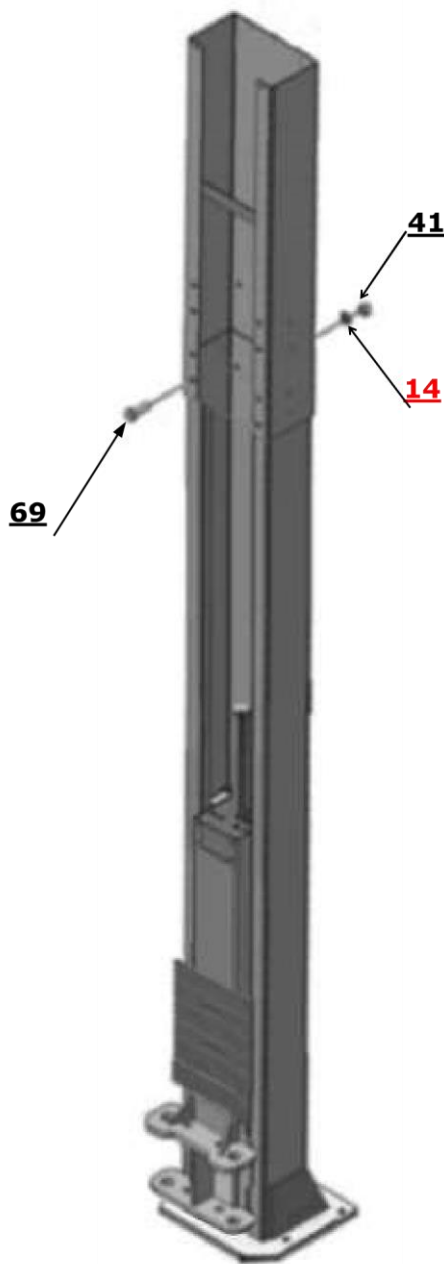

**High Setting**

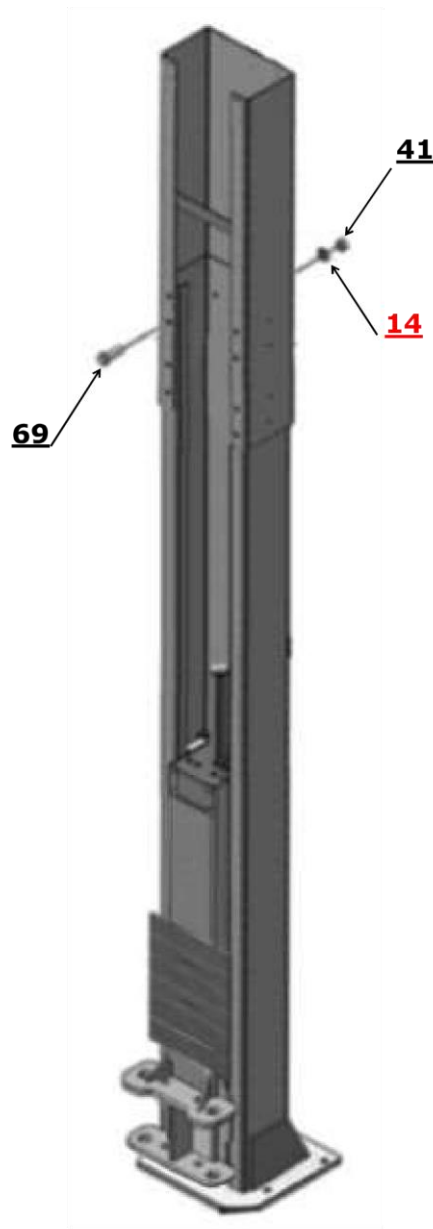

**Low Setting**

. o n

**Fig. 12**

**E P sitio columns**

Place the columns on the installation layout of base plate. Install the anchor bolts. Do not tighten the anchor bolts (**See Fig.13**).

**Fig.14**

. o n

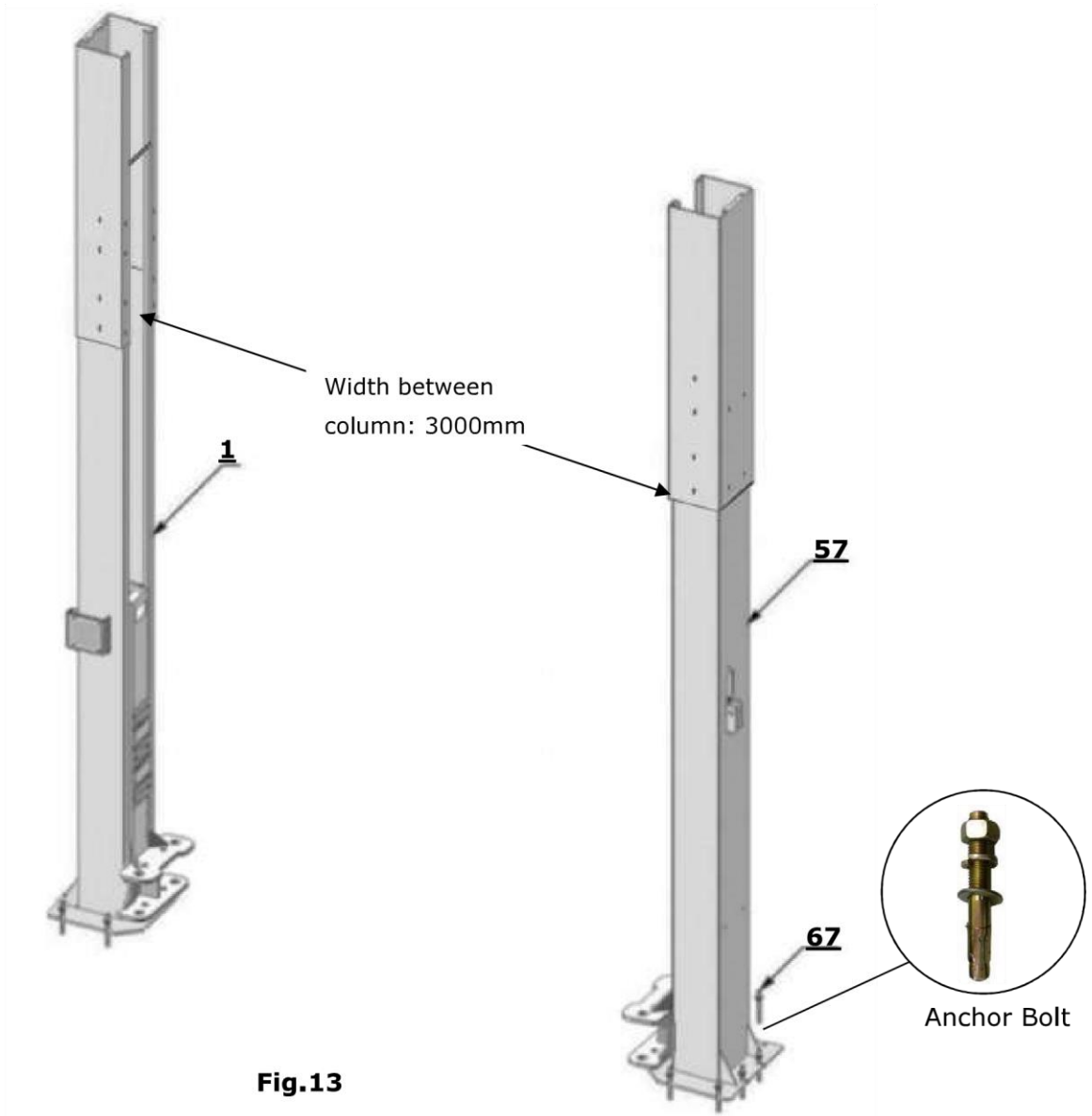

Note: Minimum embedment of anchors is 90mm.



. o n

F M unti g the top beam . Fig.15

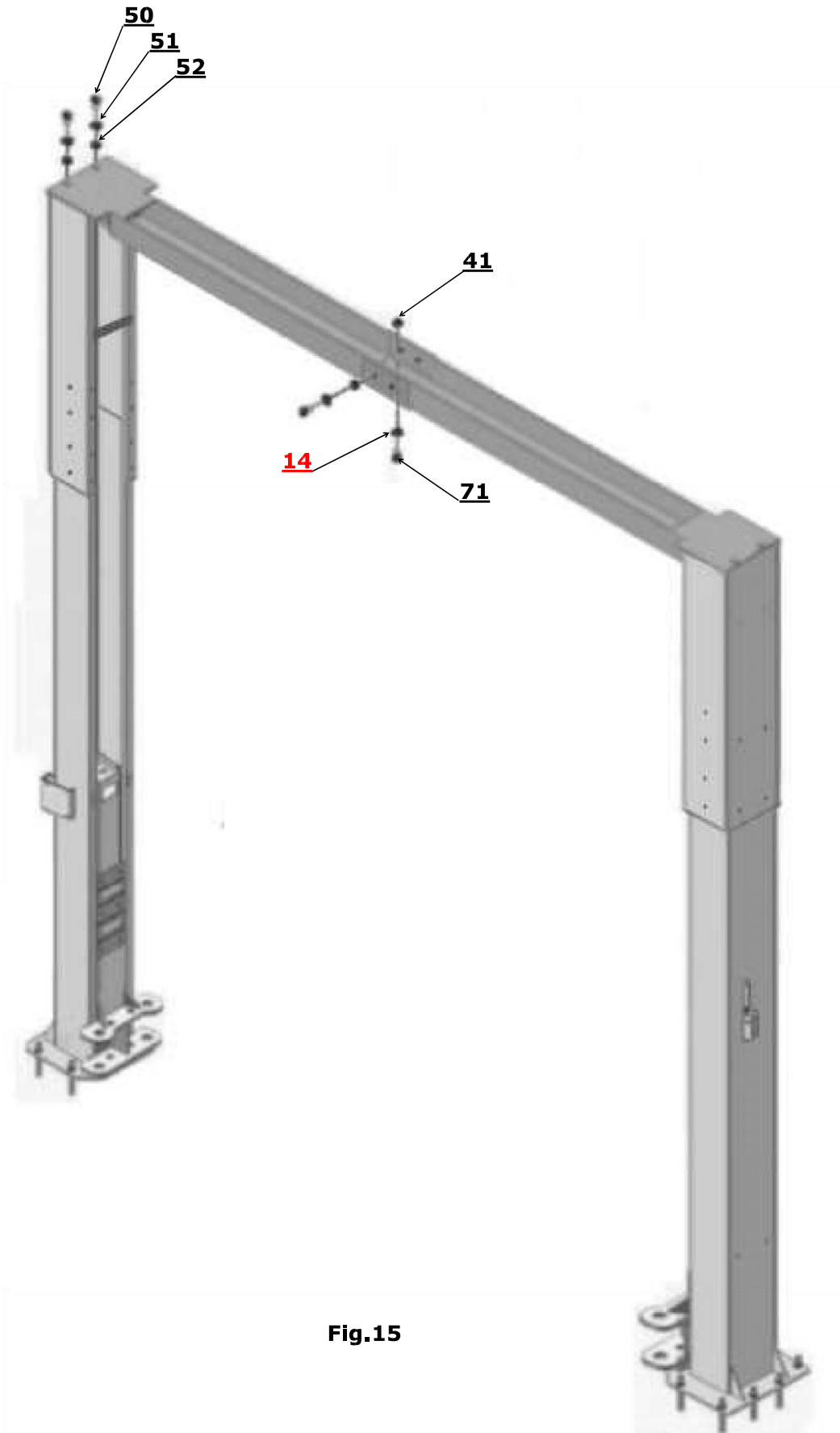
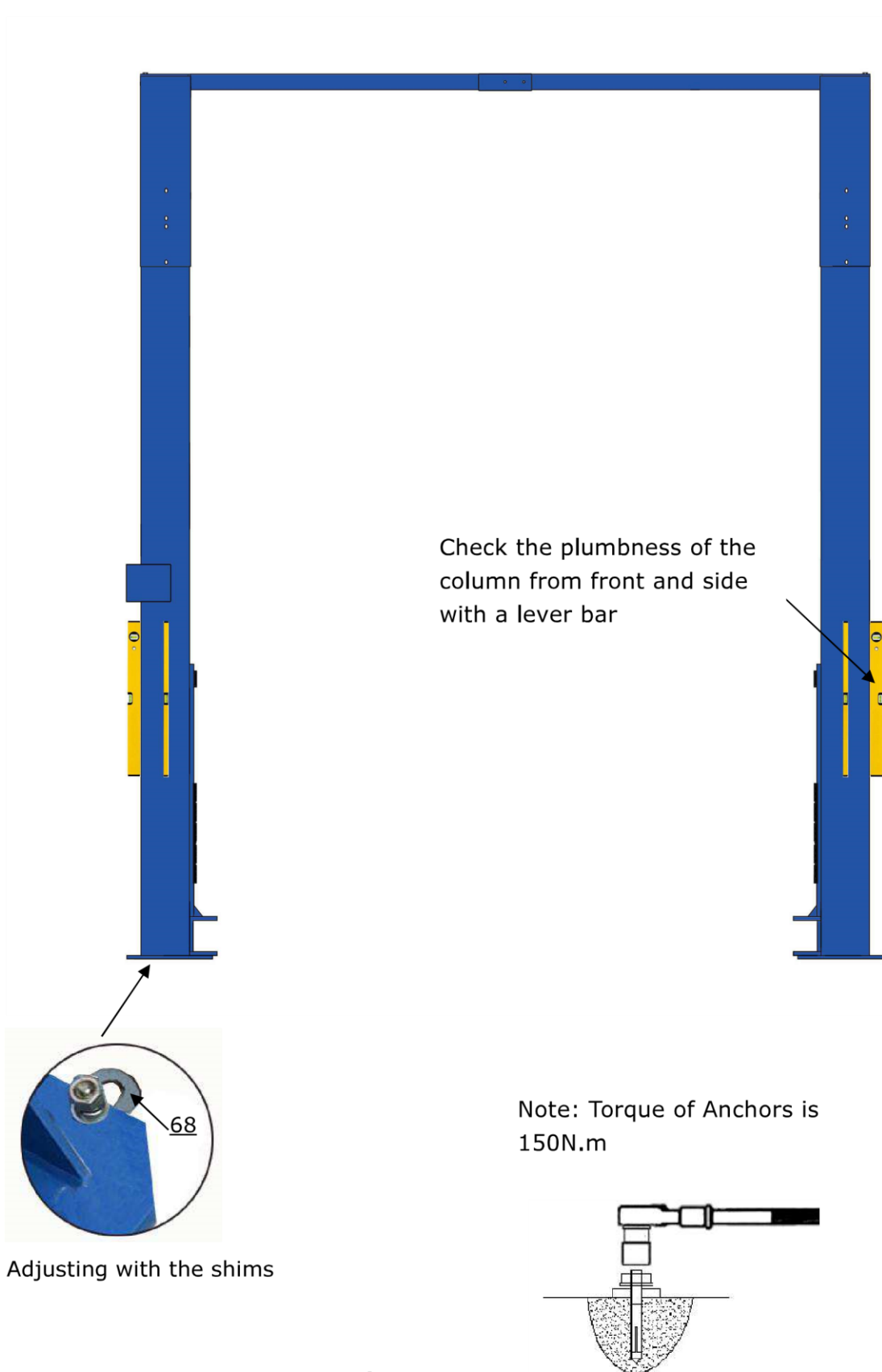

Fig.15

**G.** Check the vertical of the columns with level bar, and adjusting with the shims if the columns are not vertical. Tighten the anchor bolts (**See Fig.16**).



**Fig. 16**

**H' Install the Limit switch control bar and limit switch (See Fig. 17).**

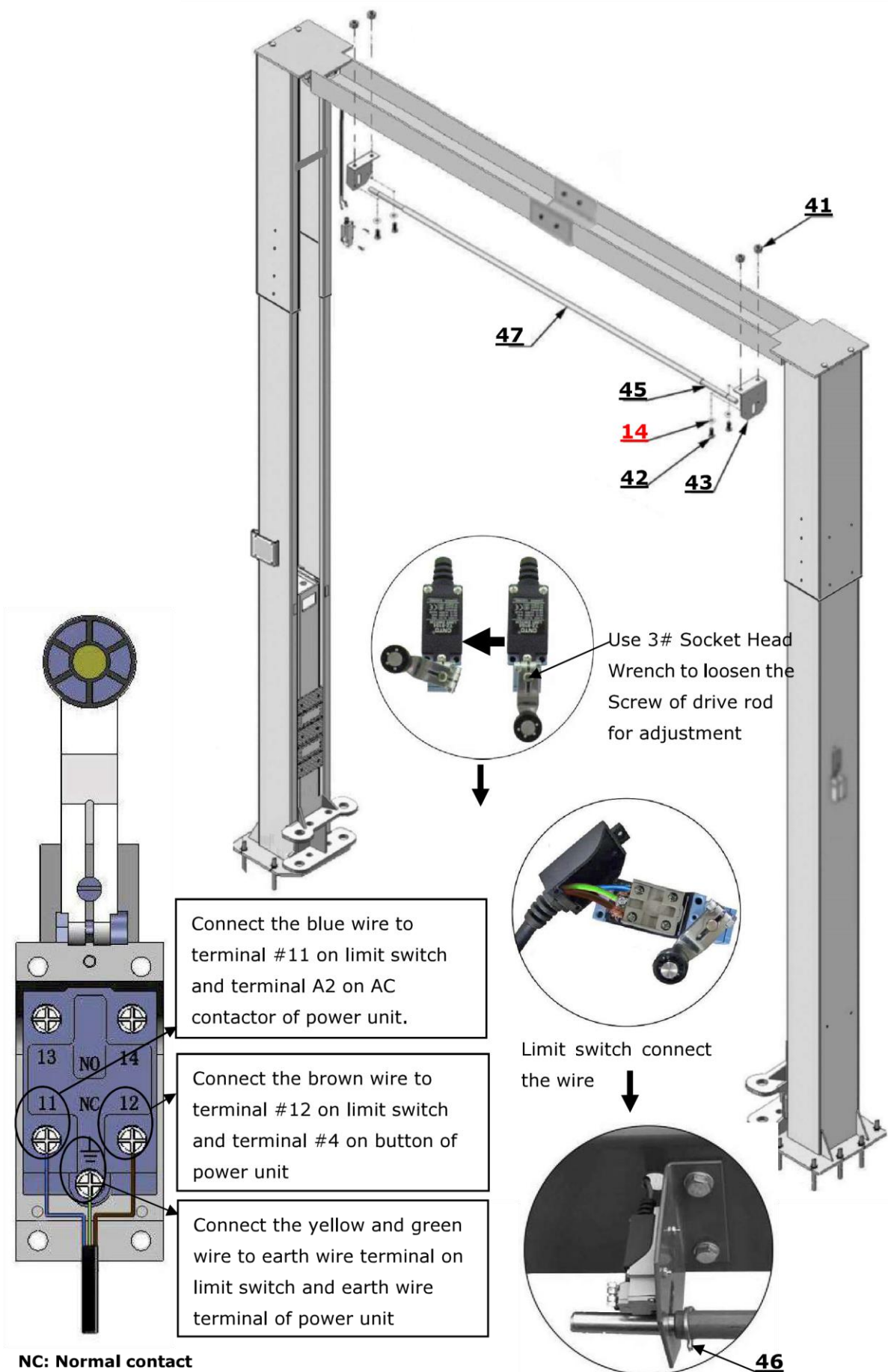

**Fig. 17**

**I' Instal' safety cable & Safety Device (See Fig. 18).**

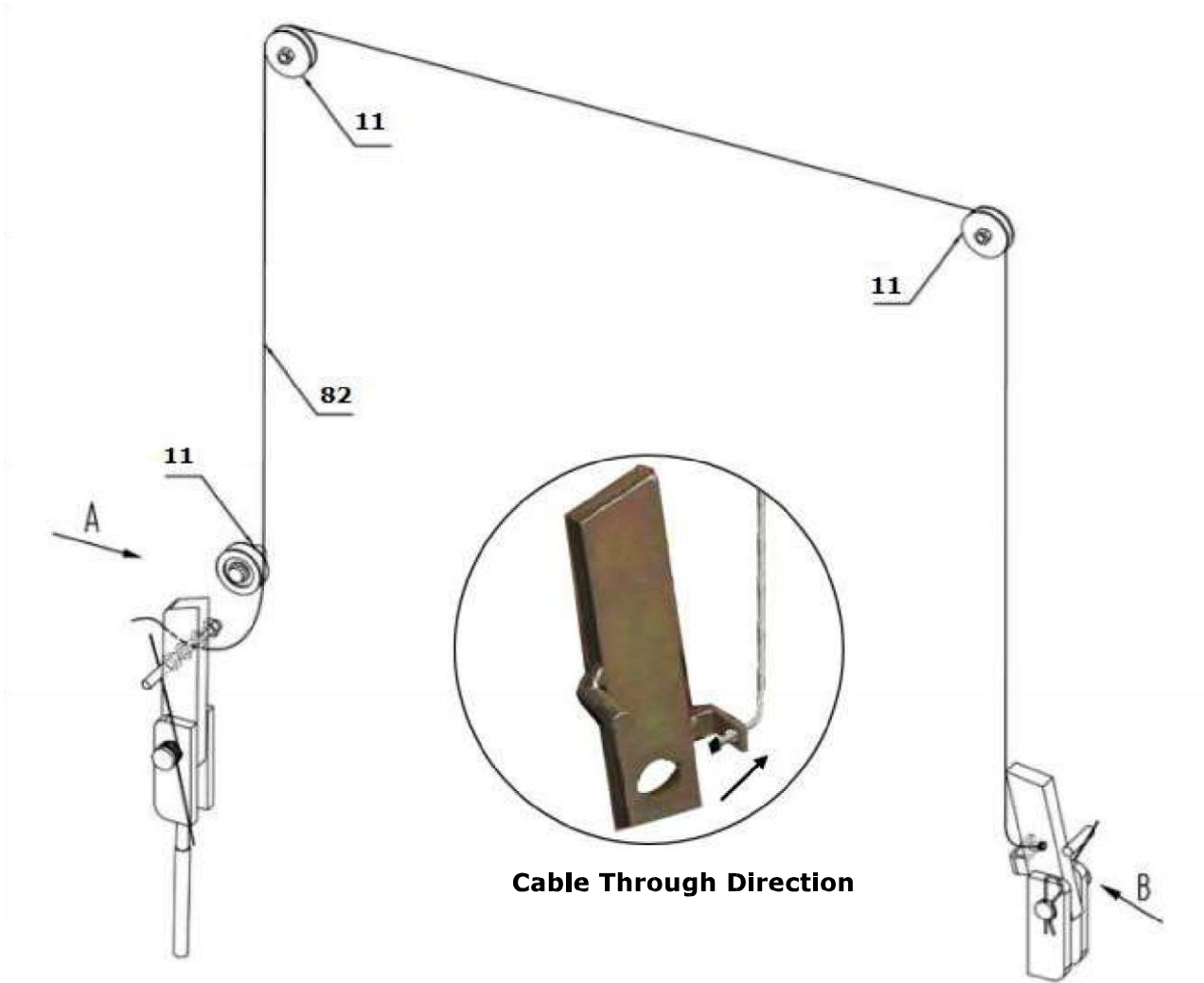



i s

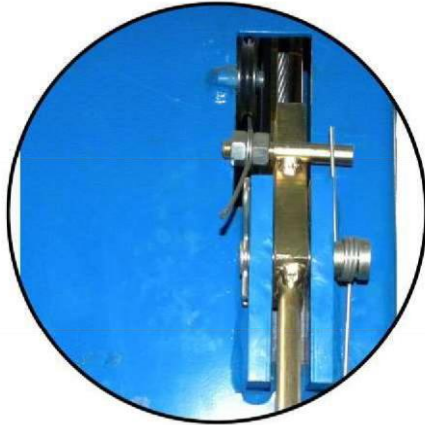

View A



View B

Fig. 18

**J Lift the carriage up by hand and make them be locked at the same level (See Fig. 19).**

**Note: Make Sure the carriage is locked by safety guard.**

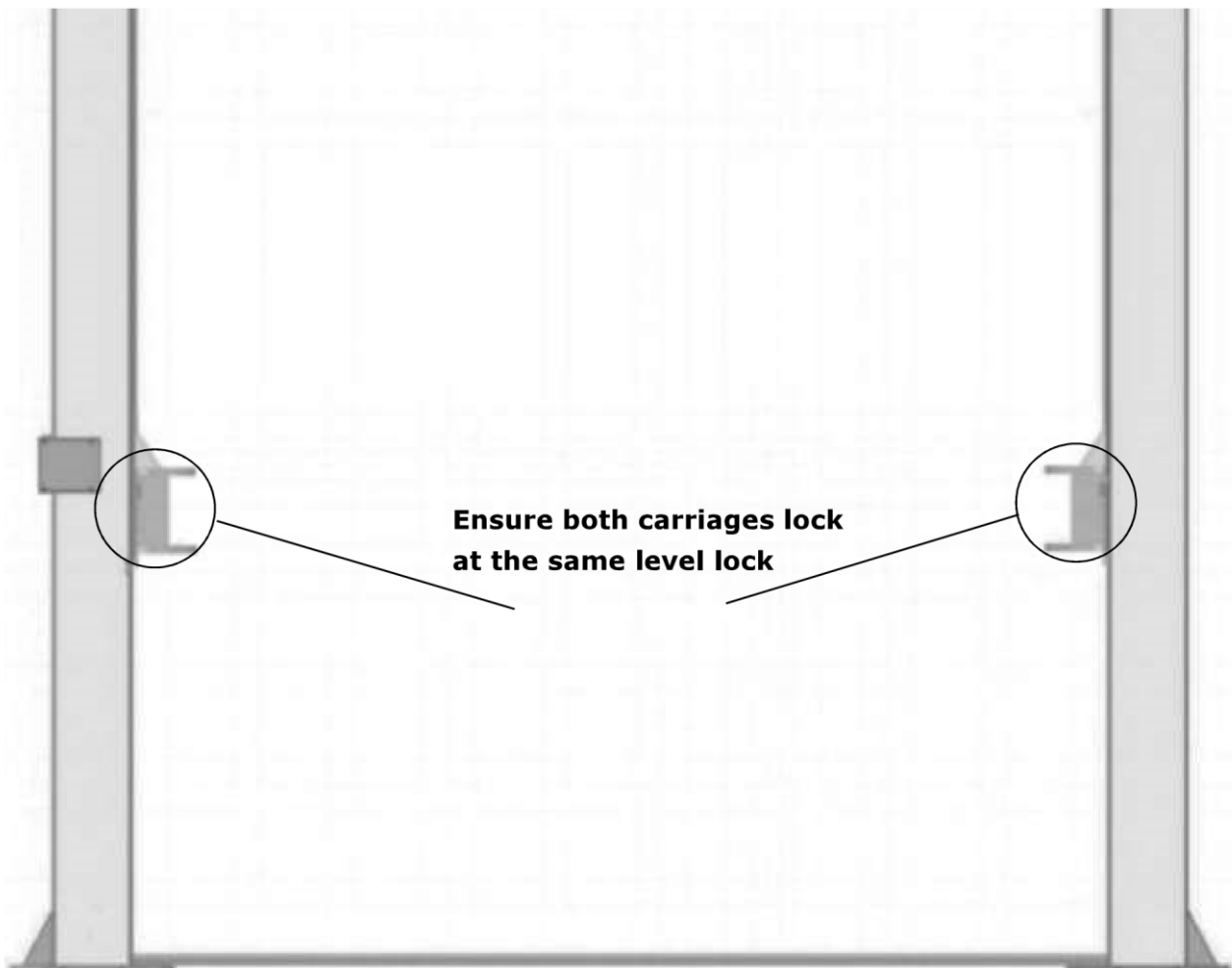

. |

**Fig. 19**

. s l

**K In tall cables (See Fig. 20).**

**Note: The cables for high setting and low setting are different.**

**High Setting:  $\phi 9.5 \times 10473 \text{mm}$**

**Low Setting:  $\phi 9.5 \times 9915 \text{mm}$**

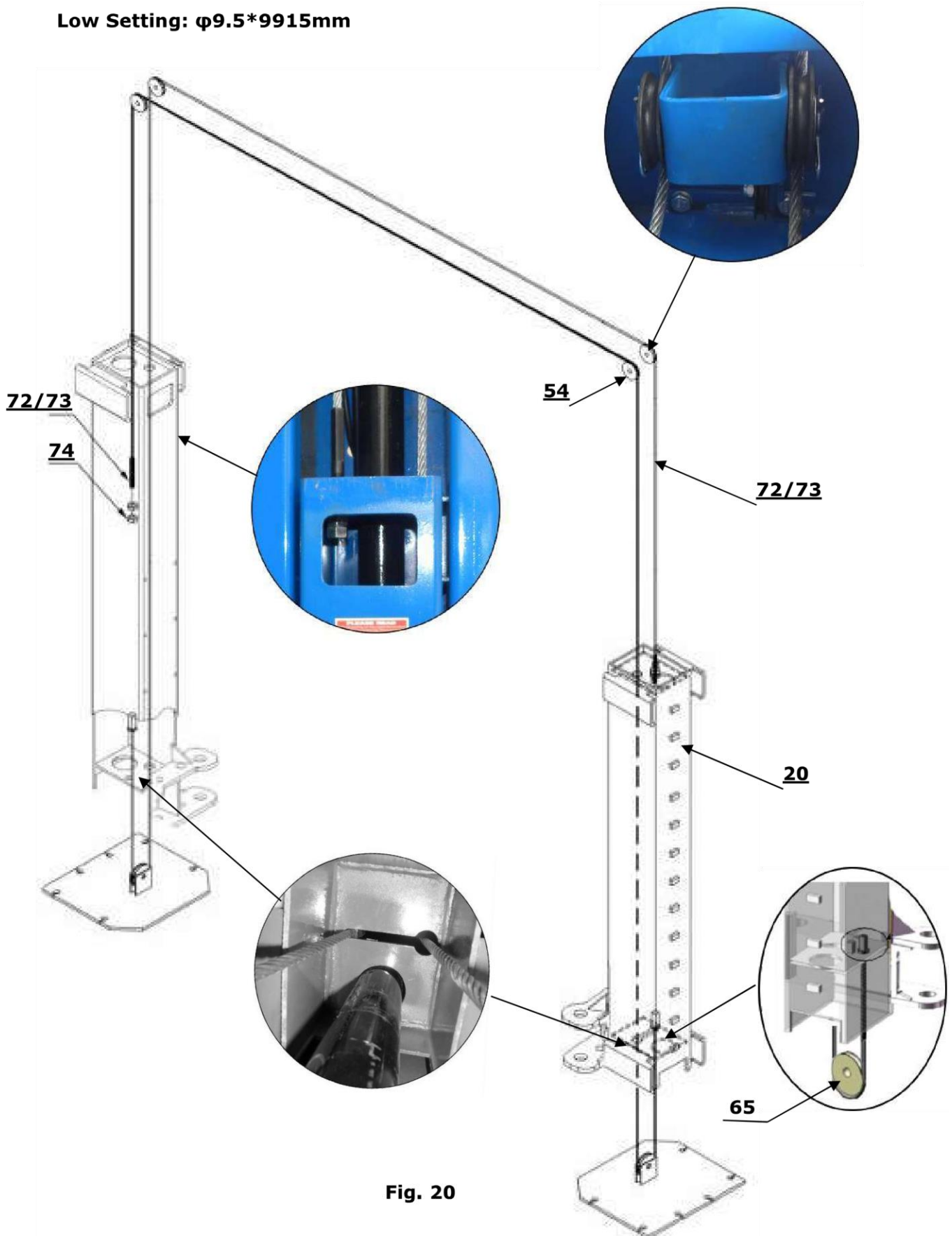

**Fig. 20**

s I

L. A sembly o I ho e, tighten all the fitting for oil hose. See fig.21  
No.78 & 79 only for high setting

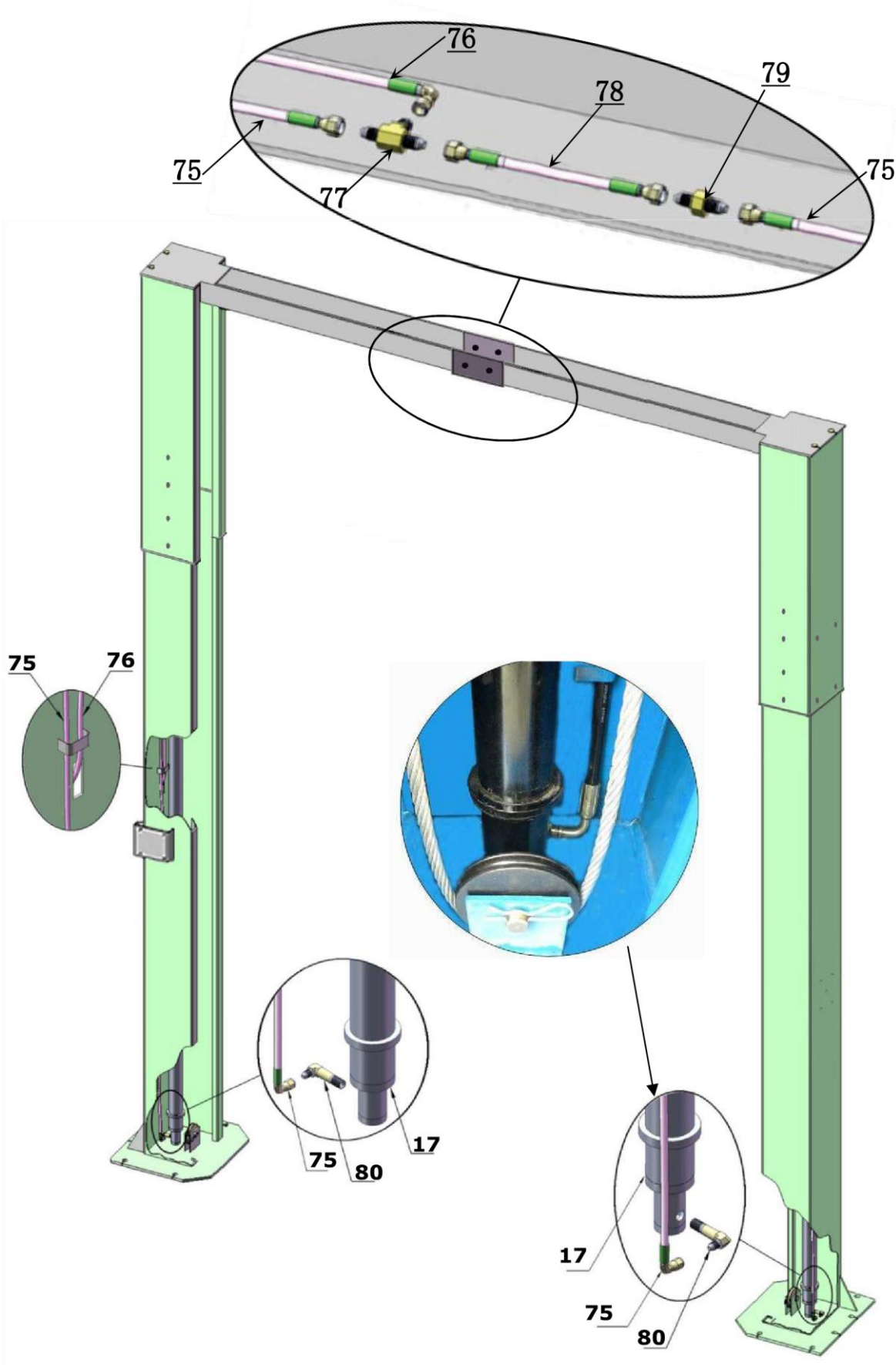
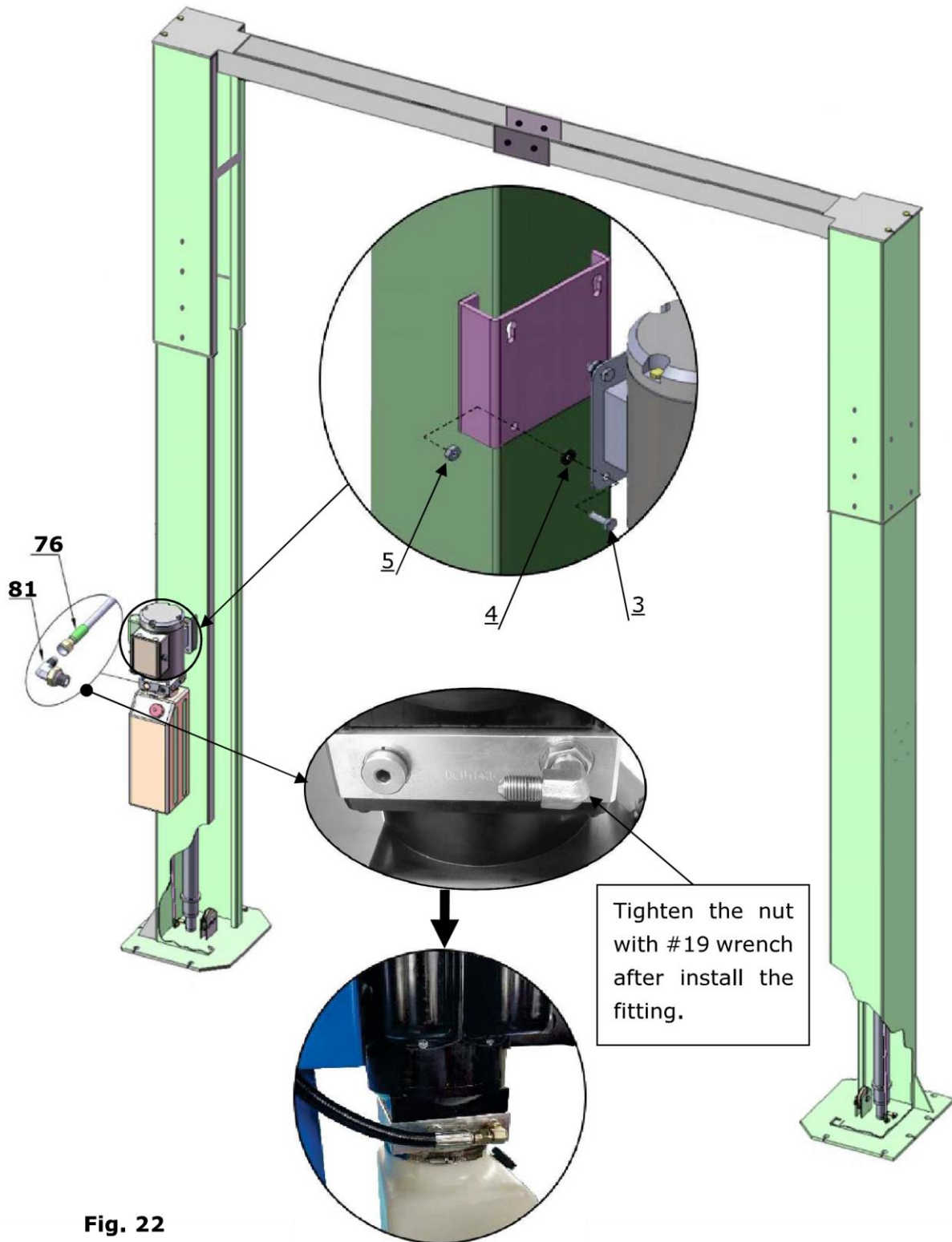

Fig. 21

s i s

**M. In tall power unit and oil hoses (See Fig. 22)**

**Pay attention to lock the fitting for hose and power unit to prevent oil leakage**



**Fig. 22**

**s l**

**N. Tighten all the hydraulic fittings, and fill the reservoir with hydraulic oil.**

**Note: In consideration of Hydraulic Power Unit's durability and keep the equipment running in the perfect condition, please use Hydraulic Oil 46#.**

## O. In<sup>S</sup> tall electrical system

Connect the power source on the data plate of power unit.

**Note: 1. For safety of operators, the power wiring must contact the floor well.**

**2. Pay attention to the direction of rotations when using three phase motors.**

### Single phase motor (See Fig. 23).

1. Connect the two power supply lines (Active **L** and Neutral Wire **N**) to terminals of AC contactor marked **L1, L2** respectively.
2. Connect the Limit Switch wire, remove the wire of connecting terminal **4#** on control button and terminal **A2** on AC contactor firstly (See Fig. 24), then connecting wire **12#** (Brown) of the limit switch with terminal **4#** of the control button and connecting wire **11#** (Blue) with terminal **A2** on AC contactor respectively. Connecting the earth wire (Green and Yellow) of the limit switch with earth wire terminal on power unit. (See Fig. 25).

Limit switch internal wires connect with NC Terminal, see Fig.17

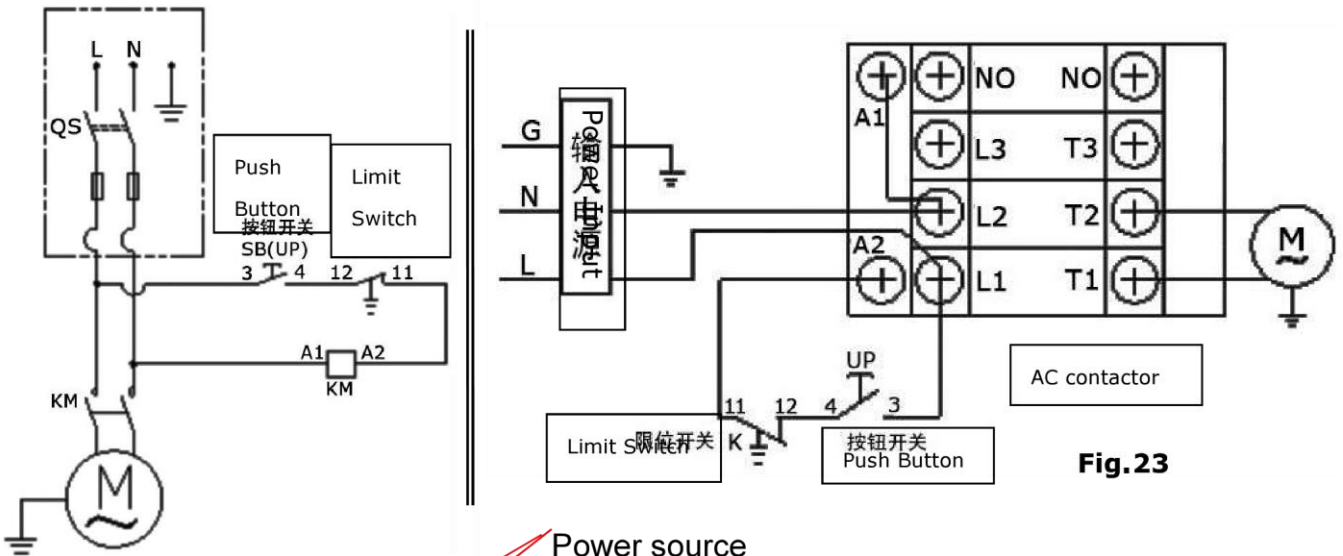

**Fig.23**

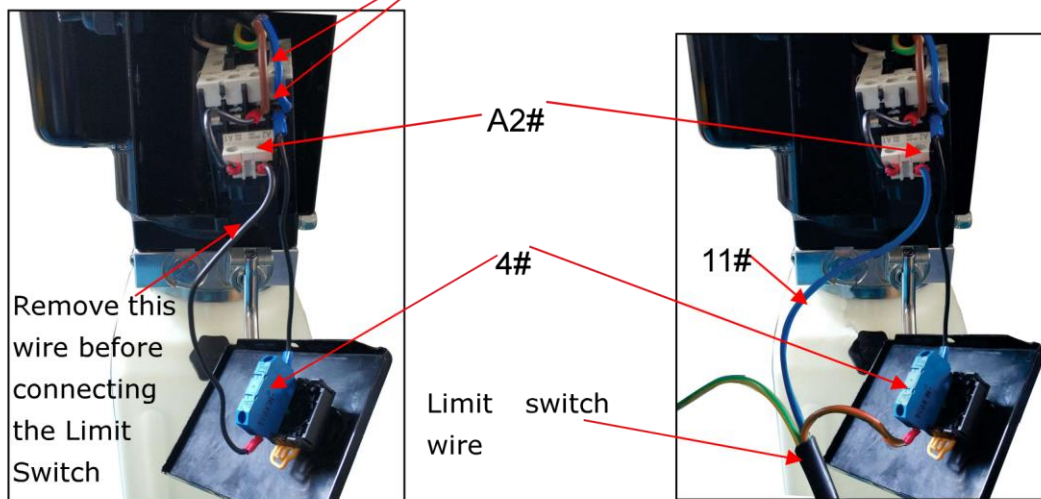
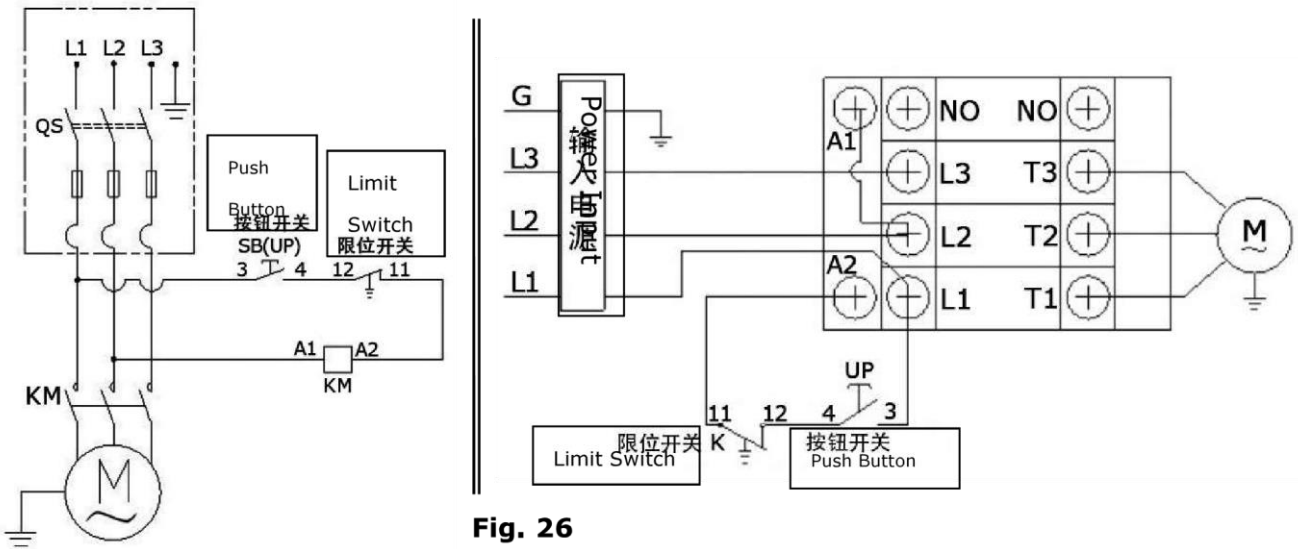

**Fig. 24**

**Fig. 25**

## Three phase motor

### 1. Circuit diagram (See Fig. 26)



### 2. Connection step (See Fig. 27)

- Connect the 3 Active wires with terminals of AC contactor marked **L1, L2, L3** respectively.
- Remove the wire connected terminal **4#** of push button and terminal **A2#** of AC contactor.
- Connect wire **12#** (Brown) of limit switch with terminal **4#** of push button ; wire **11#** (Blue) connected with **A2** terminals of AC contactor. Earth wire (Green and Yellow) of limit switch is connected with terminal earth wire of the motor.
- Terminals **3#** of control button connected with **L1** terminals of AC contactor.

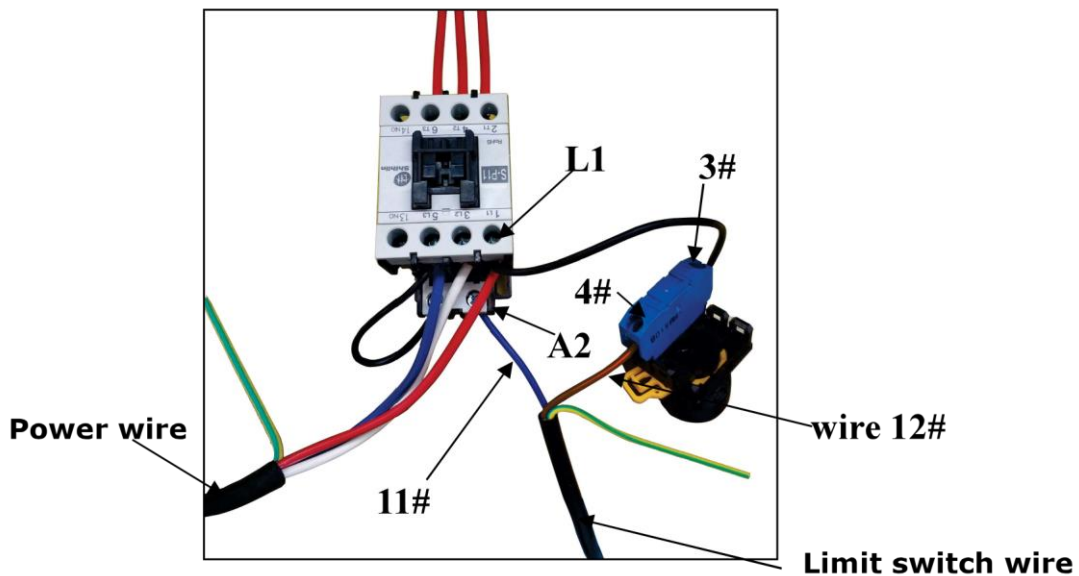



**P. Install lifting arms and adjust the arm locks**

1. Install the lifting arms (**See Fig. 28**).
2. Lowering the carriages to the lowest position, then use the 8# wrench to loosen the nut of arm lock (**See Fig. 29**).

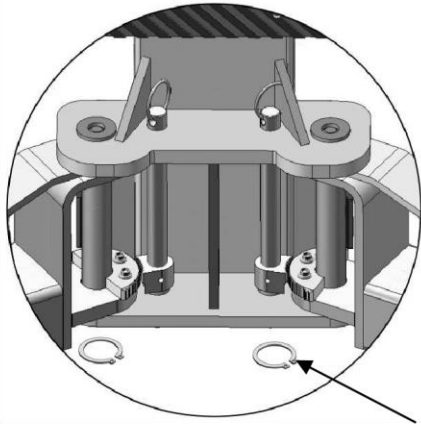

**Fig. 28**

Snap Ring

Use the 8# wrench to  
loosen the nut

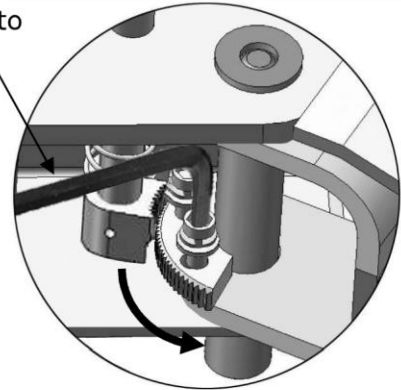

**Fig. 29**

3. Adjust the arm lock as direction of arrow (**See Fig. 30**)
4. Adjust the moon gear and arm lock to make it to be meshed, then tighten the nut of arm lock (**See Fig. 31**).

Adjust the moon gear

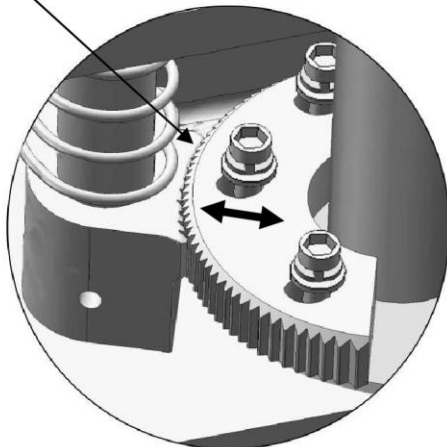

**Fig. 30**

Lock the nuts after the moon gear  
and arm lock are engaged well

Lock the nut

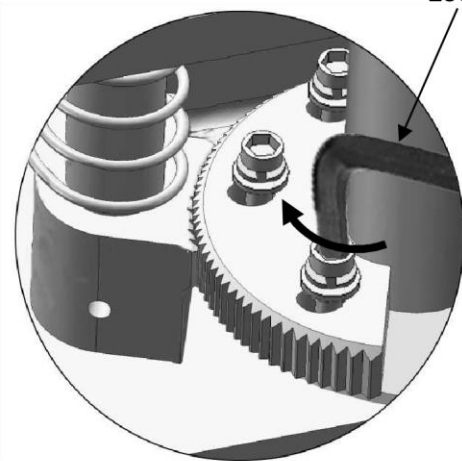

**Fig. 31**

## IV. TEST RUN

### 1. Adjust synchronous cable (See Fig. 32)

Use wrench to hold the cable fitting, meanwhile use ratchet spanner to tighten the cable nut.

Make sure two cables are with the same tension so that two carriages can work synchronously.

Fit the plastic hole cover on the lifting carriages.

**If the carriages do not synchronize when lifting, Please tighten the cable nut of lower side carriage.**

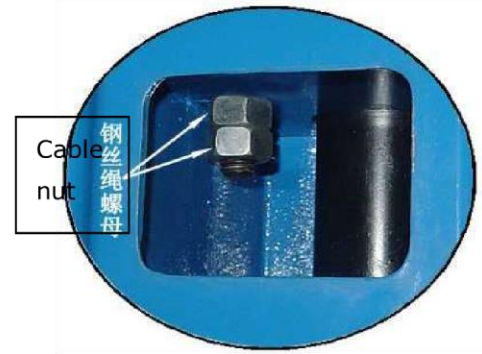

Fig. 32

### 2. Adjust safety cable

Lifting the carriages and lock at the same height, strain the safety cable and then release a little, and then tighten the cable nuts. Make sure the safety device can always be worked properly.

### 3. Bleeding air

This hydraulic system is designed to bleeding air by loosen the bleeding plug. Lifting the carriages to about 1 meter height, and loose the bleeding plug, the air would be bled automatically, then tighten the plug after bleeding, the lift would work stably and smoothly, otherwise repeat bleeding (See Fig. 33).

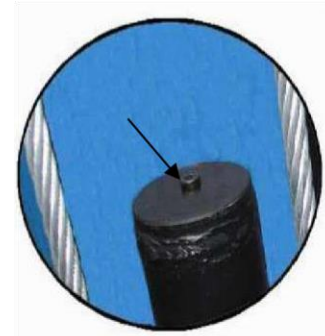
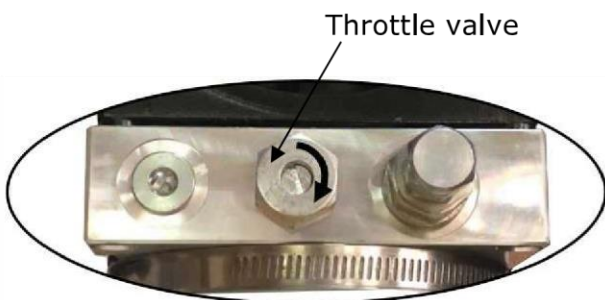

Fig. 33

### 4. Adjust the lower speed

You can adjust the lower speed of the lift if needing: Turn the Throttle Valve in clockwise direction to decrease the lower speed, or increase the speed in counterclockwise direction.



Clockwise to decrease the down speed

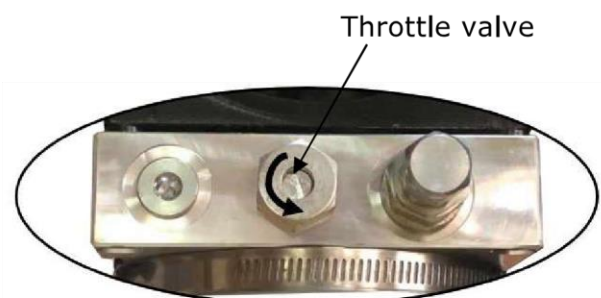

Counterclockwise to increase the down speed

**Fig.34**

**5. Test with load**

After finishing the above adjustment, test the lift with load. Raise the lift in low position for several times firstly, make sure the lift can be raised and lowered synchronously, and the safety device can be locked and released synchronously. And then raise the lift to the top position completely. If there is anything improper, repeat the above adjustment.

**NOTE: It may be vibrated when lifting at start, lifting it with load for several times, the air would be bled and the vibration would be disappeared automatically.**

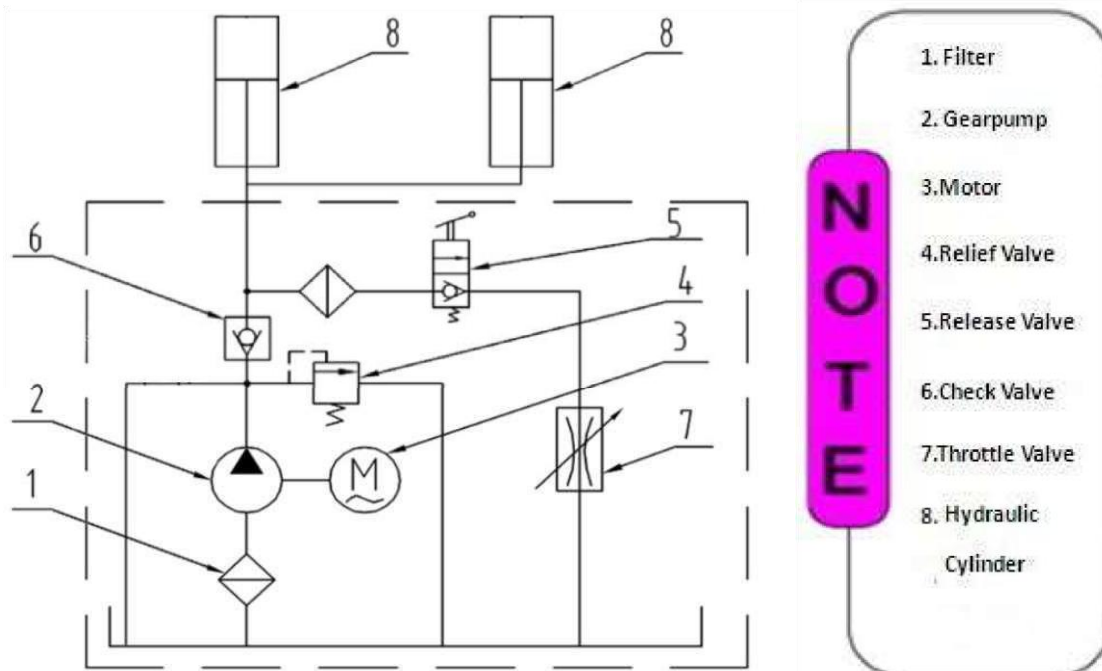

**Fig. 35 Hydraulic System**

## **V. OPERATION INSTRUCTIONS**

**Please read the safety tips carefully before operating the lift**

### **To lift vehicle**

1. Keep clean of site near the lift;
2. Position lift arms to the lowest position;
3. To shortest lift arms;
4. Open lift arms;
5. Position vehicle between columns;
6. Move arms to the vehicle's lifting point;

**Note: The four lift arms must at the same time contact the vehicle's lifting point where manufacturers recommended**

7. Push button **UP** until the lift pads contact underside of vehicle totally. Recheck to make sure vehicle is secure;
8. Continue to raise the lift slowly to the desired working height, ensuring the balance of vehicle;
9. Push lowering handle to lower lift onto the nearest safety. The vehicle is ready to repair.

### **To lower vehicle**

1. Be sure clear of around and under the lift, only leaving operator in lift area;
2. Push button **UP** to raise the vehicle slightly, and then release the safety device, lower vehicle by pushing lowering handle.
3. Open the arms and position them to the shortest length;
4. Drive away the vehicle.

Note: In order to extend the service life of the cylinder and seals, raise the machine to top at least once a day

## **VI**

### **. MAINTENANCE SCHEDULE**

#### **Monthly:**

1. Re-torque the anchor bolts to 150 Nm;
2. Check all connectors, bolts and pins to insure proper mounting;
3. Lubricate cable with lubricant;
4. Make a visual inspection of all hydraulic hoses/lines for possible wear or leakage;
5. Check safety device and make sure proper condition;
6. Lubricate all rollers and pins with 90wt. Gear oil or equivalent;

**Note: All anchor bolts should take full torque. If any of the bolts does not function for any reason, DO NOT use the lift until the bolt has been replaced.**

#### **Every six months:**

1. Make a visual inspection of all moving parts for possible wear, interference or damage.
2. Check and adjust as necessary, equalizer tension of the cables to insure level lifting.
3. Check the vertical of columns.
4. Check rubber pads and replace as necessary.
5. Check safety device and make sure proper condition.

## VI

### Oil cylinder maintenance:

In order to extend the service life of the oil cylinder, please operate according to the following requirements.

1. Recommend to use N46 anti-wear hydraulic oil.
2. The hydraulic oil of the lifts should be replaced regularly during using. Replace the hydraulic oil 3 months after the first installation, Replace the hydraulic oil once a year afterwards.
3. Make at least one full trip raising and lowering per day. For exhausting the air from the system, which could effectively avoid the corrosion of the cylinder and damage to the seals caused by presence of air or water in the system.

Protect the outer surface of the oil cylinder's piston rod from bumping and scratching, and timely clean up the debris on the oil cylinder dust-ring and the piston rod.

### I.TROUBLE SHOOTING

TROUBLE	CAUSE	REMEDY
Motor does not run	<ol style="list-style-type: none"><li>1. Button does not work</li><li>2. Wiring connections are not in good condition</li><li>3. Motor burned out</li><li>4. Height Limit Switch is damaged</li><li>5. AC Contactor burned out</li></ol>	<ol style="list-style-type: none"><li>1. Replace button</li><li>2.Repair all wiring connections</li><li>3. Repair or replace motor</li><li>4.Replace the Limit Switch</li><li>5. Replace AC Contactor</li></ol>
Motor runs but the lift is not raised	<ol style="list-style-type: none"><li>1. Motor runs in reverse rotation</li><li>2. Gear Pump out of operation</li><li>3. Release Valve in damage</li><li>4. Relief Valve or Check Valve in damage</li><li>5. Low oil level</li></ol>	<ol style="list-style-type: none"><li>1.Reverse two power wire</li><li>2.Repair or replace</li><li>3. Repair or replace</li><li>4.Repair or replace</li><li>5.Fill tank</li></ol>
Lift does not stay up	<ol style="list-style-type: none"><li>1. Release Valve out of work</li><li>2. Relief Valve or Check Valve leakage</li><li>3. Cylinder or Fittings leaks</li></ol>	Repair or replace
Lift raises slowly	<ol style="list-style-type: none"><li>1. Oil line is jammed</li><li>2. Motor running on low voltage</li><li>3. Oil mixed with Air</li><li>4. Gear Pump leaks</li><li>5. Overload lifting</li></ol>	<ol style="list-style-type: none"><li>1. Clean the oil line</li><li>2. Check electrical system</li><li>3. Fill tank</li><li>4. Replace Pump</li><li>5. Check load</li></ol>

## VI

Lift cannot lower	<ol style="list-style-type: none"><li>1. Safety device are locking</li><li>2. Release Valve in damage</li><li>3. Safety cable broken</li><li>4. Oil system is jammed</li></ol>	<ol style="list-style-type: none"><li>1. Release the safeties</li><li>2. Repair or replace</li><li>3. Replace</li><li>4. Clean the oil system</li></ol>
-------------------	--	---

## II EXPLODED VIEW

Model 210CHX

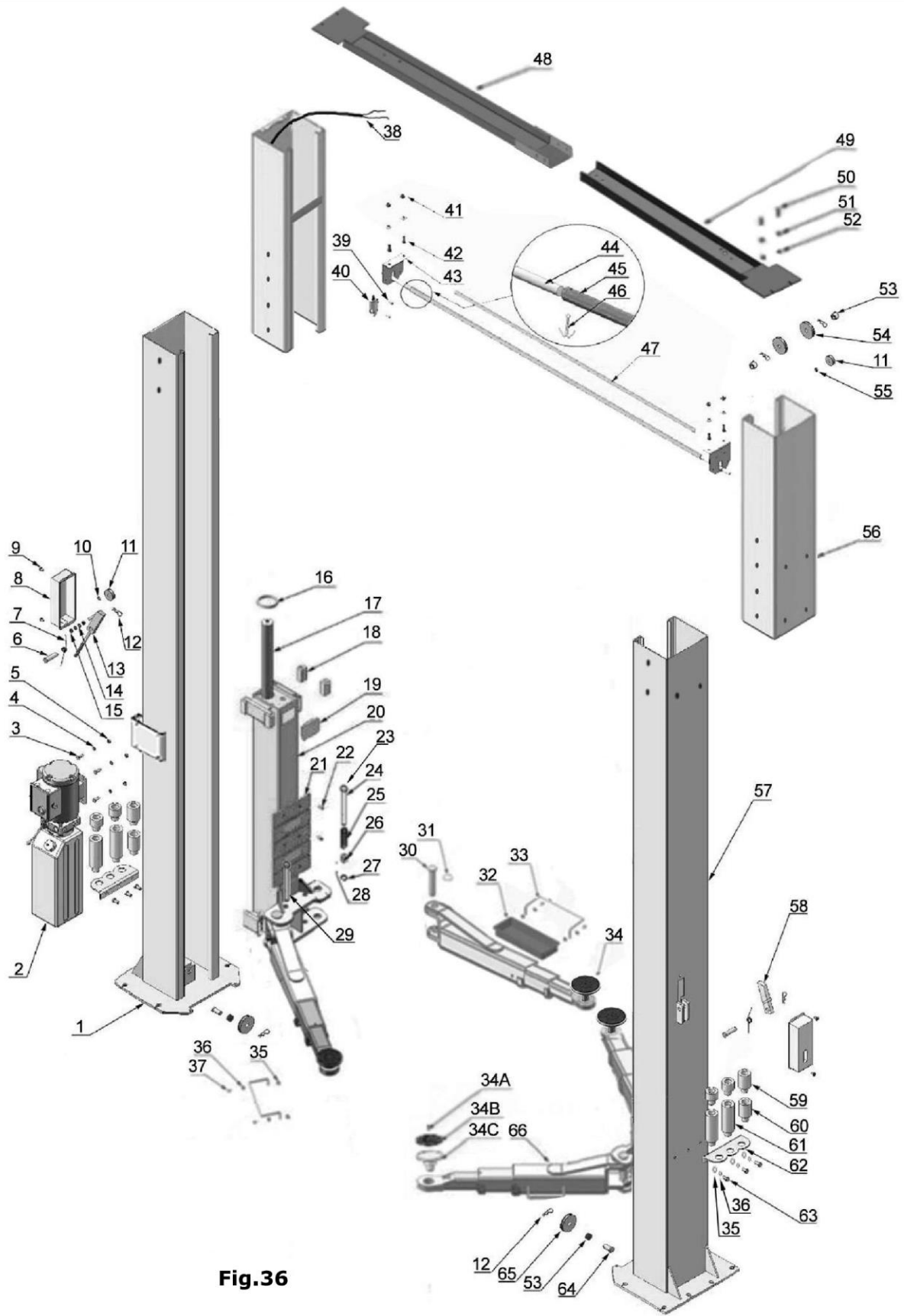

Fig.36



## PARTS LIST FOR MODEL 210CHX

Item	Part#	Description	Qty.
1	1102681000A	Power Side Column	1
2	81513001	Power Unit 220V/50Hz Single Phase	1/1
	81513002	Power Unit 380V/50Hz 3 Phase	
3	10209003	Hex Bolt M8*25	4
4	10209004	Rubber Ring φ8*20*3	4
5	10209005	M8 Self Locking Nut	4
6	11206002	Pin for Safety Block	2
7	10209007	Snap Ring	2
8	10209008	Safety Device Cover	2
9	10209009	Cup Head Bolt M6*8	4
10	10209010	φ10Snap Ring	1
11	10209049	Plastic Pulley (black)	3
12	10209012	φ3.2 Hair Pin	8
13	11209013	Power Side Safety Device	1
14	10206006	φ12Washer	12
15	10206023A	Hex Nut M12	2
16	11209111	Protective ring for cylinder	2
17	10002576001	Cylinder	2
18	10209015	Slider Block	16
19	10209016	Plastic Cover for Carriage	2
20	11209208	Carriage	2
21	10209018	Protective Rubber	2
22	10209019	Screw M6*16	12
23	10209153	Pull tab for arm lock bar	4
24	11217046A	Arm Lock Bar (Left)	2
25	10217045	Spring φ26*φ31*φ2.5	4
26	10217044	Arm Lock	4
27	10206032	Snap Ring φ25	4
28	10206036	Hair Pin φ6*40	4
29	11217046	Arm Lock Bar (Right)	2
30	11217168	Arm Pin	4
31	10520023	Snap Ring φ38	4
32	10206190	Tool Tray (Short)	2
33	11206191	Toe Guard	4
34	11217114A	Rubber Pad Assy.	4
34A	10420138	M6*16 Socket Bolt	4
34B	10209134	Rubber Pad	4
34C	11680030B	Support Frame	4
35	10209033	φ8 Washer	8
36	10209034	φ8 Lock Washer	8
37	10201002	Hex Bolt M8*16	8
38	1002685011	Wire 3*1 <sup>2</sup> *3350	1
39	10206011	Cup Head Bolt M5*12	2
40	10206013	Limit Switch	1
41	10206023	M12 Self Locking Nut	10
42	10206041	Hex Bolt M12*20	4
43	11206042	Control Bar Bracket	2
44	11206025C	Control Bar Connecting Pin	2
45	11202011	Control Bar	1

Item	Part#	Description	Qty.
46	10201005	Split Pin (φ4*50)	2
47	10206025A	Control Bar Foam Tube	1
48	1102682001A	Top Beam (Power-side )	1
49	1102682002A	Top Beam (Off-side )	1
50	10209046	Hex Bolt M10*35	4
51	10209039	φ10 Lock Washer	12
52	10209021	Hex But M10	4
53	10209057A	Bronze Bush	6
54	11206020	Pulley	4
55	10209056	M10 Self Locking Nut	2
56	1102681002A	Outer Column	2
57	1102681000B	Off-Side Column	1
58	11211013	Off-Side Safety Device	1
59	11209051B	Stackable Adapter (1.5")	4
60	11209052B	Stackable Adapter (2.5")	4
61	11209053B	Stackable Adapter (5.5")	4
62	11209054A	Adapter Bracket.	2
63	10680003	Hex Bolt M8*12	4
64	11209044	Pulley Pin	2
65	11209045	Pulley	2
66	10203156	Front Arm Assy.	4
67	10209059	Anchor Bolts	12
68	10201090	Shim (1mm)	12
	10620065	Shim (2mm)	12
69	10206024	Hex Bolt M12*25	20
70	10209502B	Parts Box	1
71	10217069	Hex Bolt M12*30	6
72	1002695009	Cable Φ9.52×10473mm(High setting)	2
73	1002695005	Cable Φ9.52×9915mm(Low setting)	2
74	10209066	Hex Nut M16	8
75	1002695004-01	Oil Hose 1/4*5598mm	2
76	1002695003-01	Oil Hose 1/4*4548mm	1
77	10211016	T Fitting	1
78	1002571009-01	Oil Hose 1/4*550mm	1
79	10620079	Straight Fitting	1
80	10211017	90° Fitting for cylinder	2
81	10209060	90° Fitting for Power Unit	1
82	1002685001	Safety Cable Φ2.5*8500mm	1
83	10209502B	Parts Box	1

# 1 Lifting arm assy. (10203156) explosive view

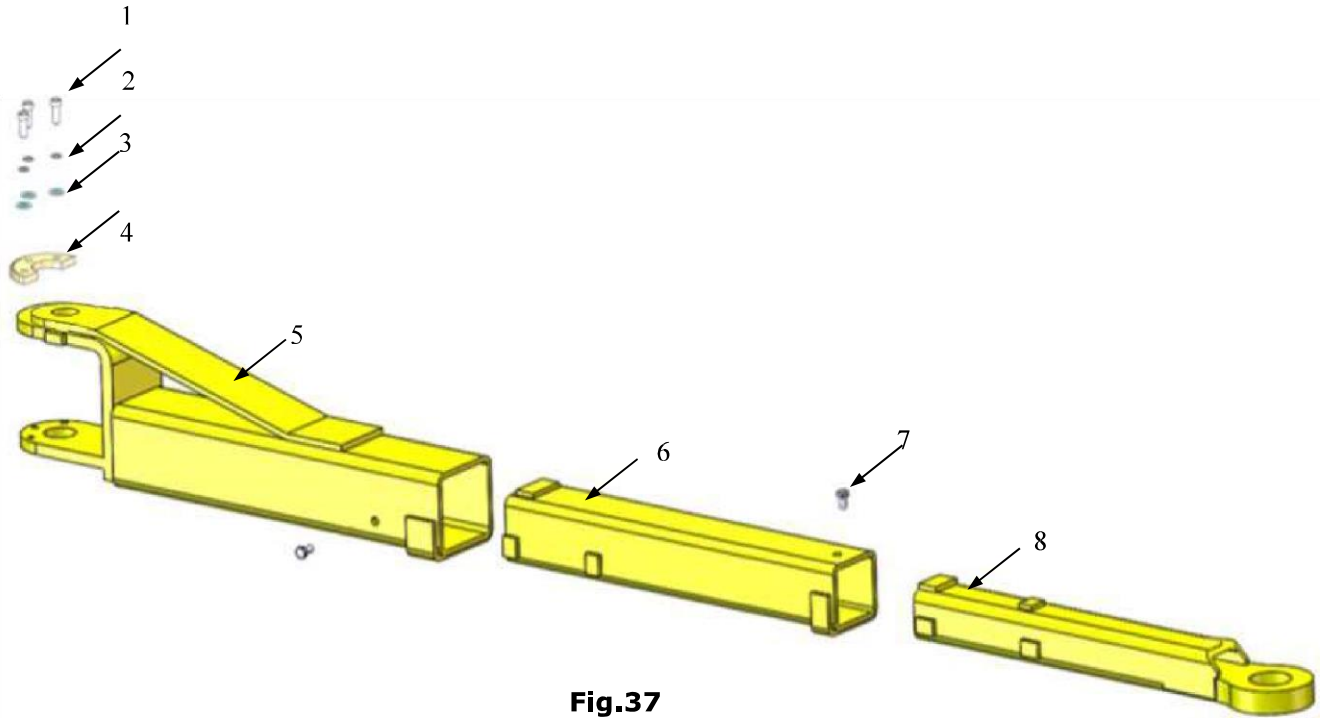
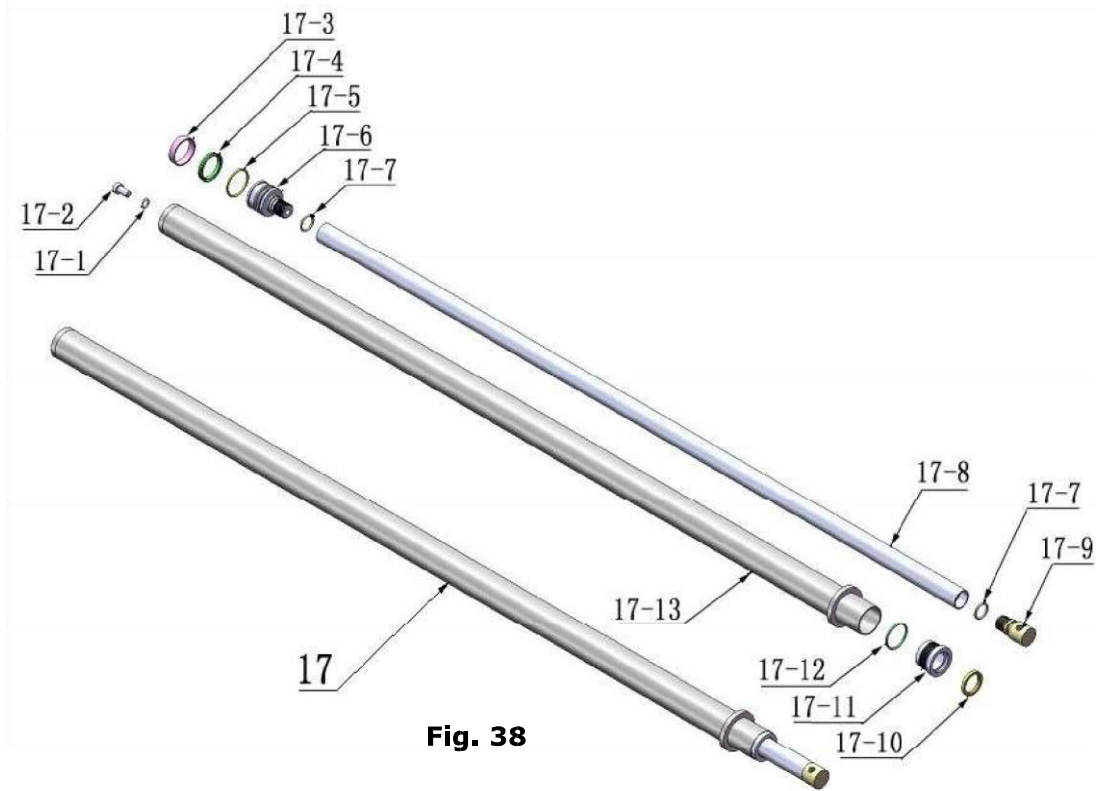

**Fig.37**

No	Part no	Name	QTY
1	10206048	Socket bolt	12
2	10209039	Lock Washer	12
3	10209022	Washer	12
4	11206049	Moon gear	4
5	11203146	Outer arm	4
6	11203147	Middle arm	4
7	10201149	Cup head bolt	8

8	11203148	Inner arm	4
---	----------	-----------	---

## 2' Cylinders (1002576001) explosive view



**Fig. 38**

## Part list for cylinder

<b>No</b>	<b>Part no</b>	<b>Name</b>	<b>QTY</b>
17-1	10209069	O ring	2
17-2	10209070	Bleeding Plug	2
17-3	10209071	Support Ring	2
17-4	10209072	Y ring	2
17-5	10209073	O ring	2
17-6	11209074	Piston	2
17-7	10209075	O Ring	4
17-8	1102576002	Piston rod	2
17-9	11209077	Piston Rod Fitting	2
17-10	10209078	Dust wing	2
17-11	11209079	cover	2
17-12	10209080	O ring	2
17-13	1102576003	Bore Weldment	2

### 3 POWER UNIT (81513001/81513002) explosive view

220V/50HZ/Single Phase

380V/50HZ/3Phase

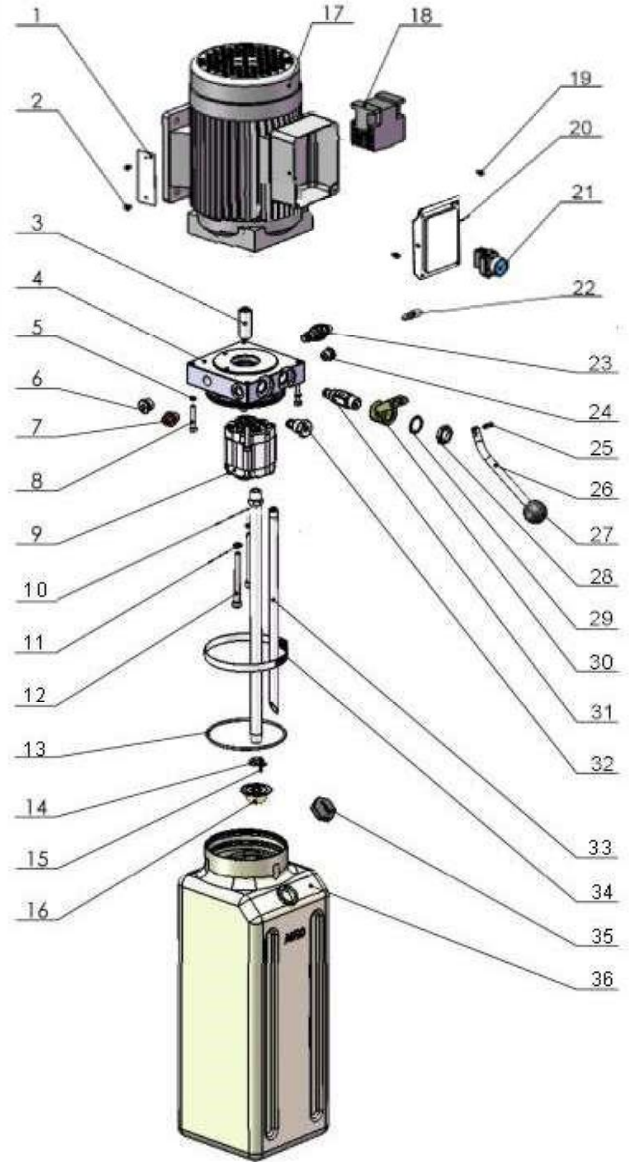
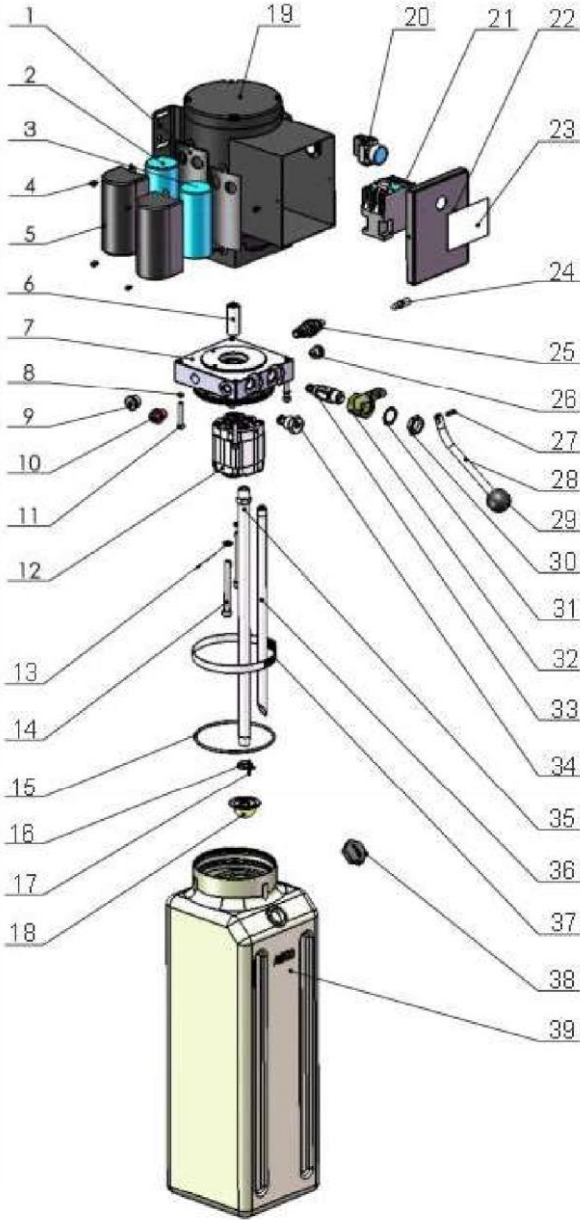

Fig. 39

**PARTS LIST FOR MANUAL POWER UNIT**

<b>Parts for Manual Power Unit 220V/50Hz/Single phase</b>				
<b>Item</b>	<b>Part#</b>	<b>Description</b>	<b>Qty.</b>	<b>Note</b>
1	81400180	Rubber pad	2	
2	81400250	Starting capacitor	1	
3	81400200	Running capacitor	1	
4	10420148	Screw with washer	6	
5	81400066	Capacitor cover	2	
6	81400363	Motor connector	1	
7	80101013	Manifold block	1	
8	10209149	Washer	4	
9	81400276	Plug	1	
10	81400259	Red plug	1	
11	85090142	Hex bolt	4	
12	81400280	Gear pump	1	
13	10209034	washer	2	
14	81400295	Hex nut	2	
5	81400365	O-ring	1	
16	10209152	Tape	1	
17	85090167	Magnet	1	
18	81400290	Filter	1	
19	81400413	Motor	1	
20	10420070	Button switch	1	
21	41030055	AC contractor	1	
22	81400287	Motor box cover	1	
23	71111170	AMGO label	1	



24	81400560	Throttle valve	1	
25	81400266	Relief valve	1	
26	81400284	Plug	1	
27	10720118	Elastic pin	1	
28	81400451	Release handle	1	
29	10209020	Plastic ball	1	
30	81400421	Release valve nut	1	
31	81400422	Release handle	1	
32	81400449	valve seat(short)	1	
33	81400567	Release valve	1	
34	81400566	Check washer	1	
35	81400288	Oil suction hose	1	
36	81400289	Oil return hose	1	
37	81400364	Hose clamp	1	
38	81400263	Oil tank cap	1	
39	81400275	Oil tank	1	

<b>Parts for Manual Power Unit 380V/50Hz/3 phase</b>				
1	71150055	AMGO Name plate	1	
2	81400300	Cup Head Bolt	2	
3	81400363	Motor Connecting Shaft	1	
4	81400362	Manifold block	1	
5	10209149	Washer	4	
6	81400276	Iron plug	1	
7	81400259	Red rubber plug	1	
8	85090142	Hex bolt	4	
9	81400292	Gear pump	1	
10	81400288	Oil pipe	1	
11	10209034	Lock Washer	2	
12	81400295	Socket bolt	2	
13	81400365	O ring	1	
14	10209152	Ties	1	
5	85090167	Magnet	1	
16	81400290	Filter	1	
17	81400439	Motor	1	
18	81400348	AC connector	1	
19	10420148	Cup head screw	2	
20	80101022	Cover of Motor Terminal Box	1	
21	10420070	Switch	1	
22	81400560	Throttle valve	1	
23	81400266	Relief valve	1	
24	81400284	Plug	1	
25	81400452	Elastic pin	1	
26	81400451	Release handle	1	

27	10209020	Plastic ball	1	
28	81400421	Release valve nut	1	
29	81400422	Self-locking shim	1	
30	81400449	Valve seat(short)	1	
31	81400567	release valve	1	
32	81400566	Check valve	1	
33	81400289	Oil return pipe	1	
34	81400364	Pipe ring	1	
35	81400263	Oil tank cap	1	
36	81400275	Oil tank	1	

## Illustration of hydraulic valve for hydraulic power unit

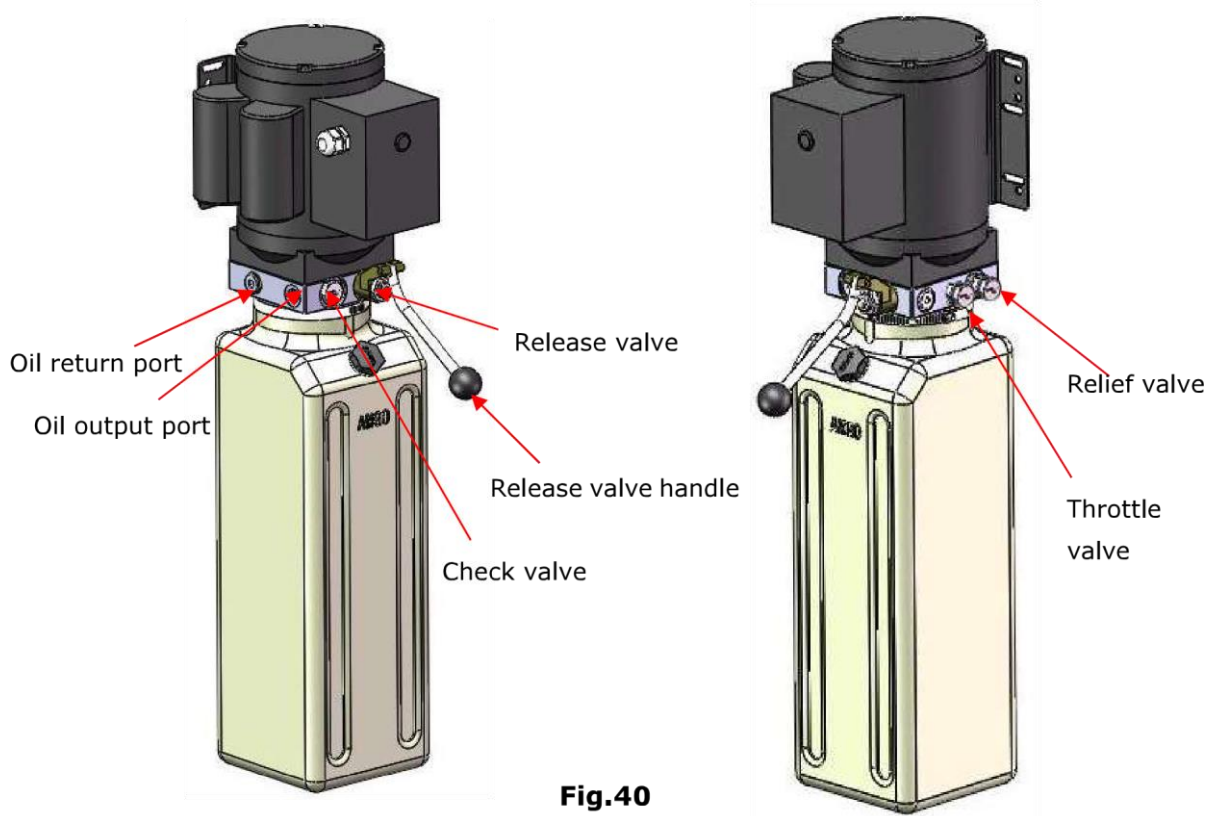

## IX. Lift Disposal

When the car lift cannot meet the requirements for normal use and needs to be disposed, it should follow local laws and regulations.



**AUSTRALIA'S  
BIGGEST RANGE OF 2 POST HOISTS**

**Classic Lift Australia**

[www.classiclift.com.au](http://www.classiclift.com.au)

**1800 951 022**