

CLASSIC LIFT

Installation And Service Manual

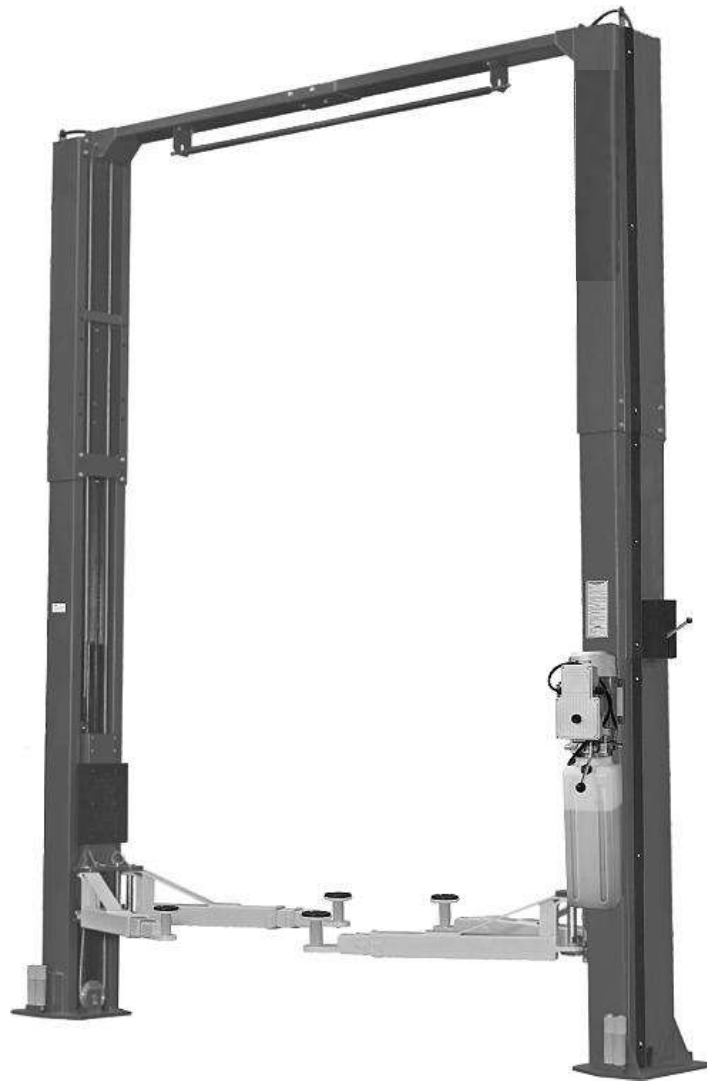

Two-Post Lift

Model: CL5500C

CONTENTS

Product Features and Specifications	1
Installation Requirement	3
Installation Steps	5
Exploded View	27
Test Run	37
Operation Instruction	39
Maintenance	40
Trouble Shooting	41
Lift Disposal	41

I. PRODUCT FEATURES AND SPECIFICATIONS

CLEAR-FLOOR DIRECT-DRIVED MODEL FEATURES

Model CL5500C (See Fig. 1)

- Direct-driven design, minimize the lift wear parts and breakdown ratio
- Dual hydraulic cylinders, designed and made on high standards, utilizing imported oil seal in cylinder
- Self-lubricating UHMW Polyethylene sliders and bronze bush
- Single-point safety release with dual safety design
- Clear-floor design, provide unobstructed floor use
- Overhead safety shut-off device prevents vehicle damage
- Standard adjustable heights accommodates varying ceiling heights

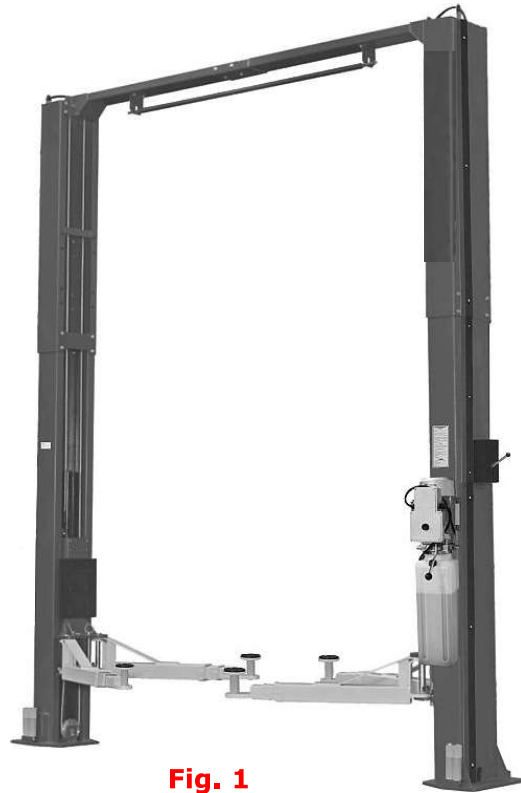

Fig. 1

Model	Lifting Capacity	Lifting Time	Lifting Height	Overall Height	Overall Width	Minimum Pad Height	Motor
CL5500C	5500kg	69S	1842-2071mm	4420/5029mm	3829mm	115-344mm	4.0 HP

MODEL CL5500C SPECIFICATIONS

Arm Swings View

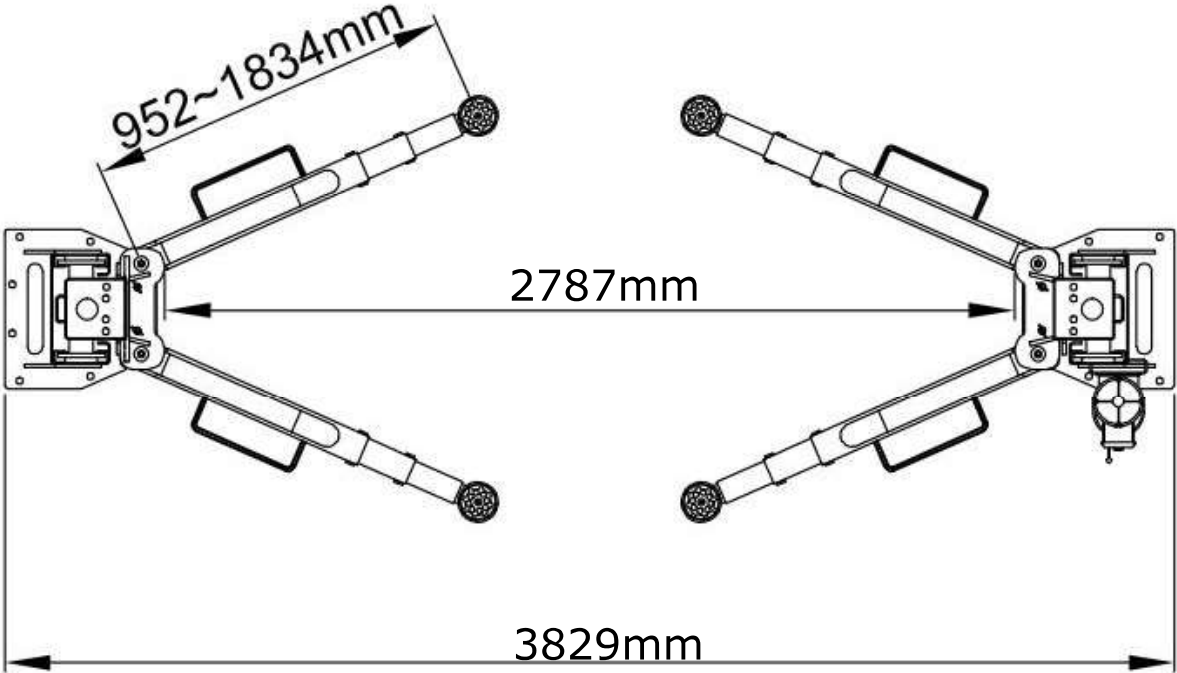

Fig. 2

II. INSTALLATION REQUIREMENT

A. TOOLS REQUIRED

- ✓ Rotary Hammer Drill (Φ19)



- ✓ Hammer



- ✓ Level Bar



- ✓ English Spanner (12")



- ✓ Ratchet Spanner With Socket (28#)



- ✓ Wrench set
(10#, 13#, 14#, 15#, 17#, 19#, 24#, 27#, 30#)



- ✓ Carpenter's Chalk



- ✓ Screw Sets



- ✓ Tape Measure (7.5m)



- ✓ Pliers



- ✓ Socket Head Wrench (3#, 5#, 8#)



- ✓ Lock Wrench



Fig. 3

B. Equipment storage and installation requirements.

The equipment should be stored or installed in a shady, normal temperature, ventilated and dry place.

C. The equipment should be unload and transfer by forklift.



Fig.4

D. SPECIFICATIONS OF CONCRETE (See Fig. 5)

Specifications of concrete must be adhered to the specification as following.
Failure to do so may result in lift and/or vehicle falling.

1. Concrete must be thickness 200mm minimum and without reinforcing steel bars, and must be totally dry before lift installation.
2. Concrete must be in good condition and must be of test strength 3,500psi (245kg/cm²) minimum.
3. Floors must be level with no cracks or holes.

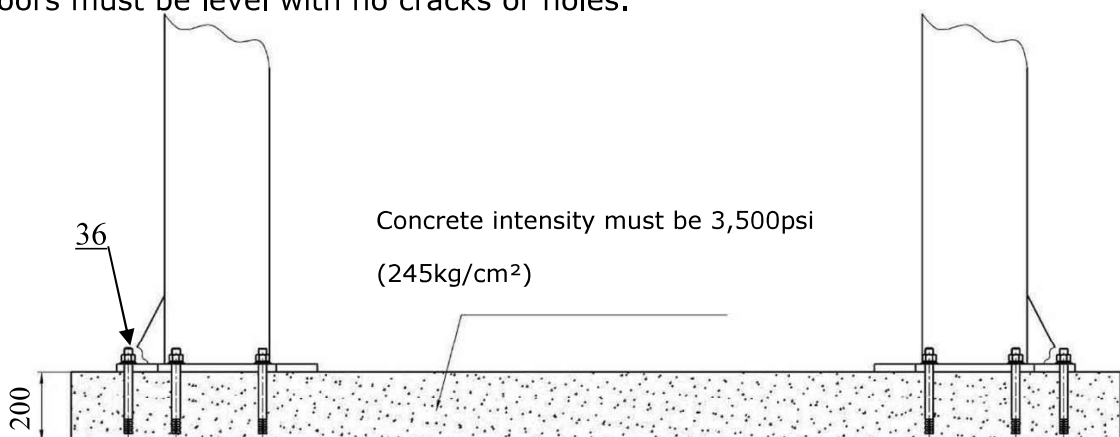

Fig. 5

E. POWER SUPPLY

The electrical source must be 3kw minimum. The source cable size must be 2.5mm² and in good condition of contacting with floor.

III. INSTALLATION STEPS

A. Location of installation

Check and ensure the installation location (concrete, layout, space size etc.) is suitable for lift installation.

B. Use a carpenter's chalk line to establish installation layout of base-plate (See Fig. 6).

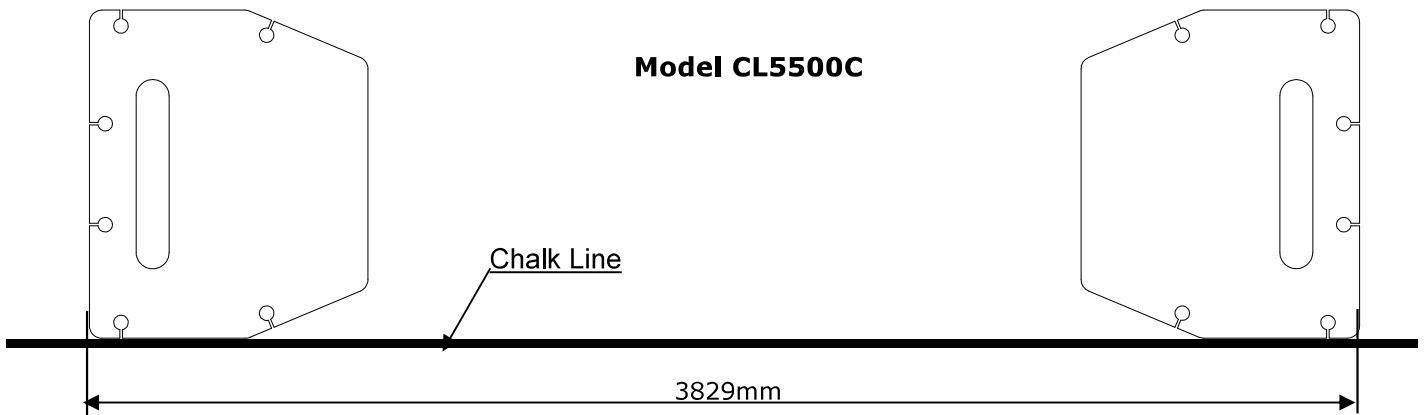
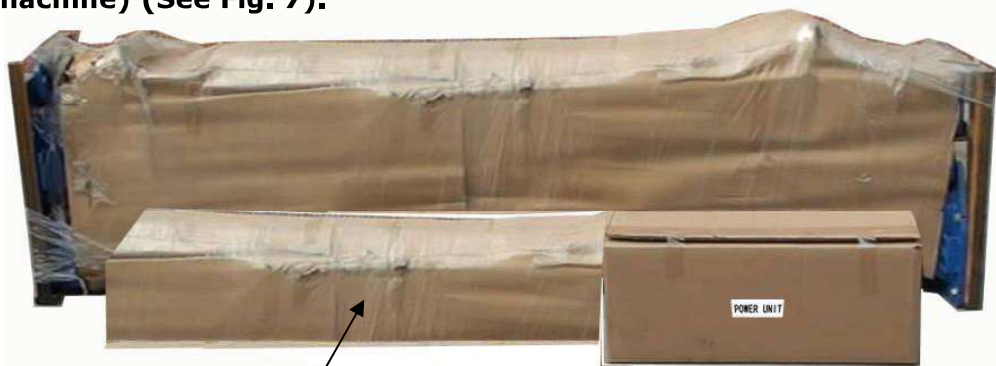

Fig. 6

C. Check the parts before assembly.

1. Packaged lift and hydraulic power unit (Remark: Outer column is not packed into the machine) (See Fig. 7).



Outer column

Fig. 7

2. Move the lift aside with a fork lift or hoist, and open the outer packing carefully (See Fig. 8).

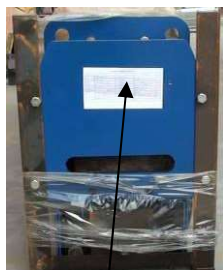

Shipment Parts list

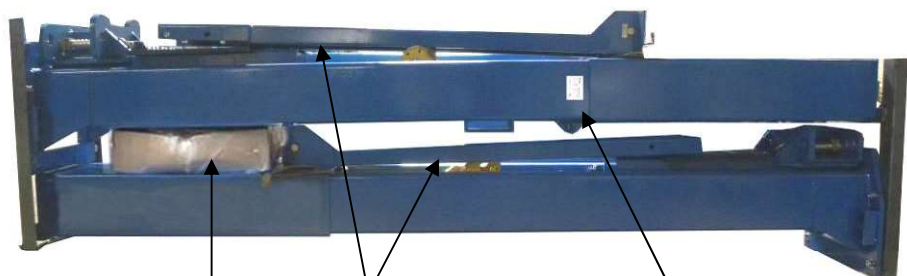

Parts box

Top beam Assy.

Name Plate

Fig. 8

3. Remove aside the top top beam assy. (See Fig. 9).



Fig. 9

4. Lift the upper column with a fork lift or hoist, loose the bolts of the upper package stand, take off the upper extension column, then take out the parts in the inner column (See Fig. 10).

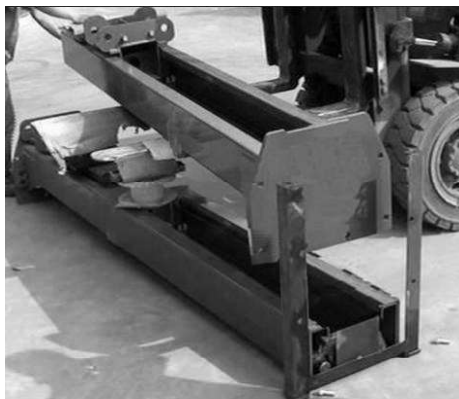

Fig. 10

5. Lift the lower column with a fork lift or hoist, take down the package stand, than take off the lower extension column, take out the parts in the inner column (See Fig. 11).

Lift the lower column
with a fork lift or hoist

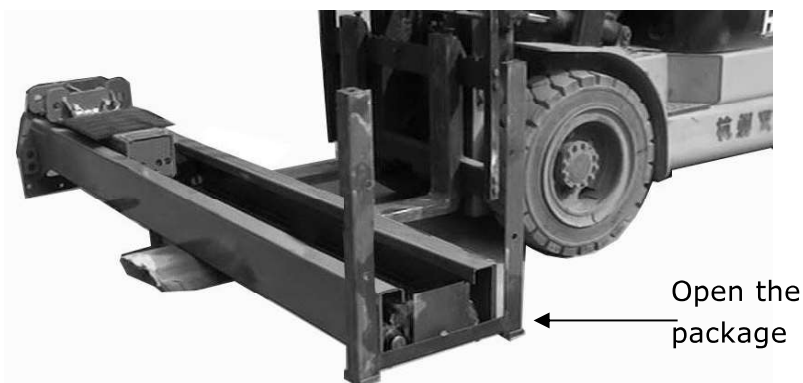
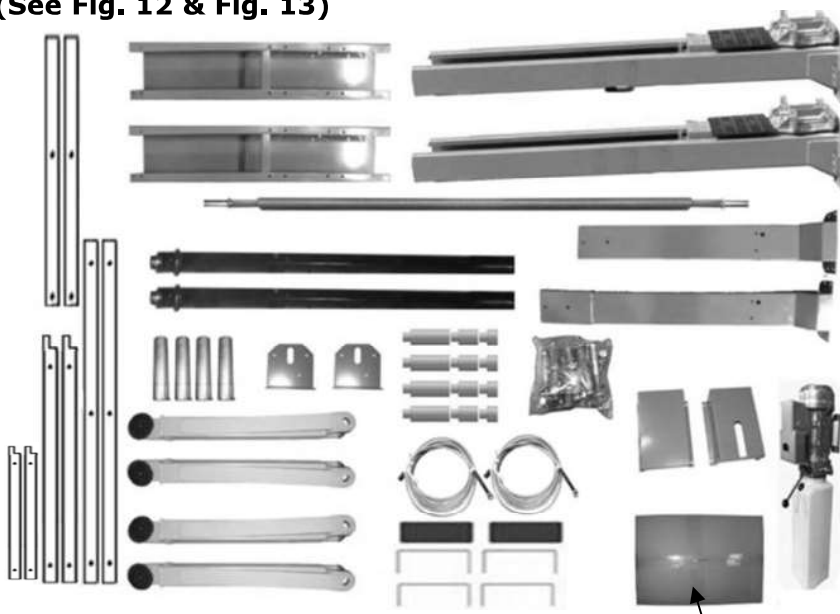

Fig. 11

6. Move aside the parts and check the parts according to the shipment parts list

(See Fig. 12 & Fig. 13)



Parts list

Fig. 12



Parts box list (111)

Fig. 13

7. Check the parts of the parts bag 1# according to parts bag list (See Fig. 14).



Fig. 14



8. Check the parts of the parts bag 2# according to parts bag list (See Fig. 15).



Fig. 15



D. Install parts of outer columns (See Fig. 16).

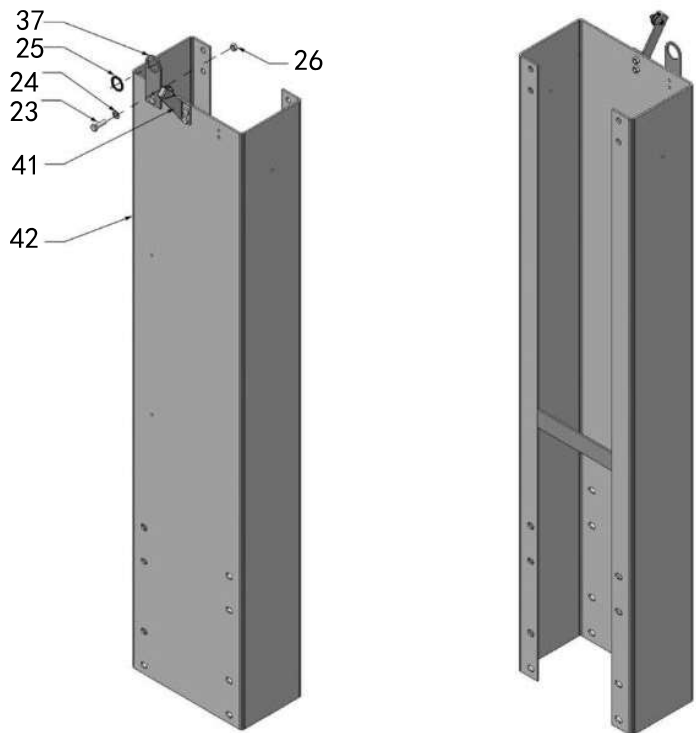
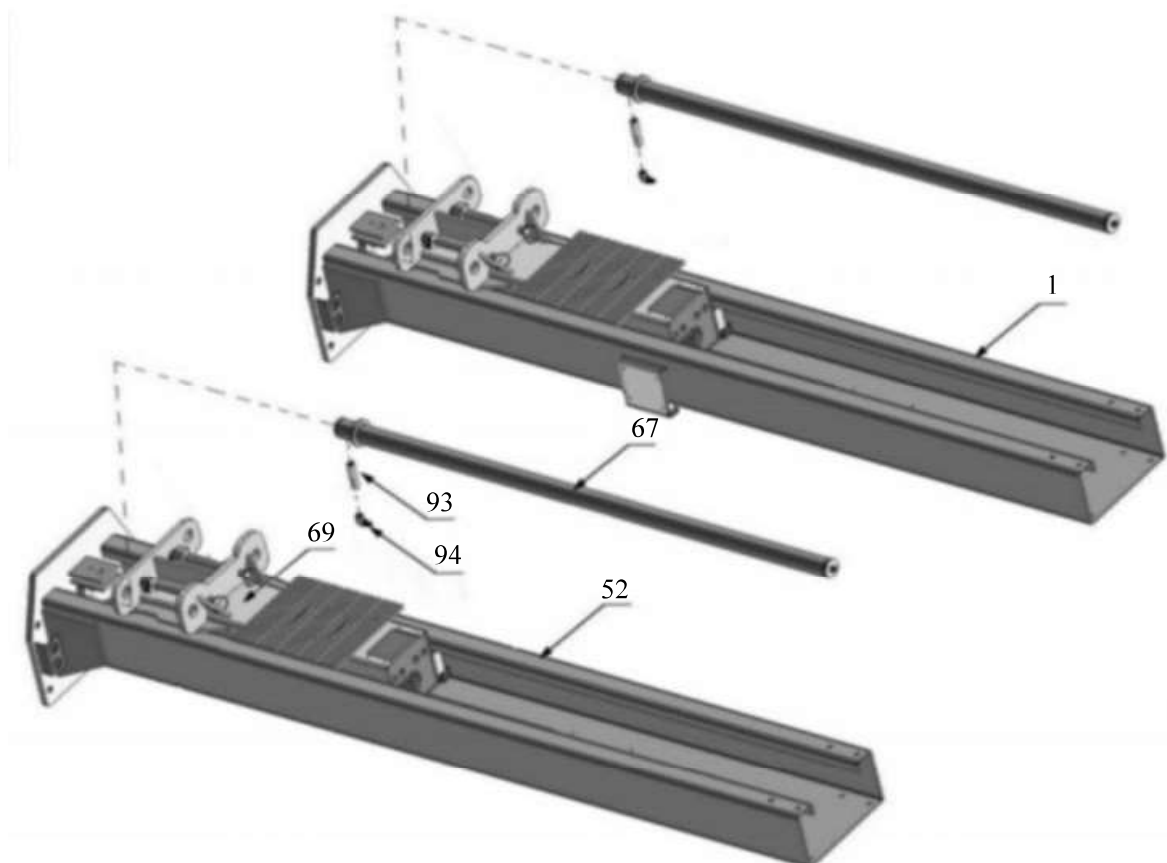

Fig. 16

E. Install hydraulic cylinder

Wind enough seal tape on the extended straight fitting and 90° fitting, and connecting the fittings, and then install the cylinder into the carriages (See Fig. 17).





Seal tape

Assemble the cylinder into the column



Fig. 17

The fitting of the cylinder toward the hole



F. Install columns

Lay down two columns on the installation site parallelly, position the power-side column according to the actual installation site. Usually, it is suggested to install power-side column on the right of vehicles driven-in. This lift is designed with 2-section columns. Adjustable height according to the ceiling height and connecting the inner and extension columns.

If the ceiling height is over 5035mm, it can be installed in a high setting; if the ceiling height between 4430mm - 5035mm, it can be installed in the low setting; it is not allowed to install if the ceiling height less than 4430mm.

1. High Setting, connecting the extension columns with the lower hole (**See Fig. 18**).

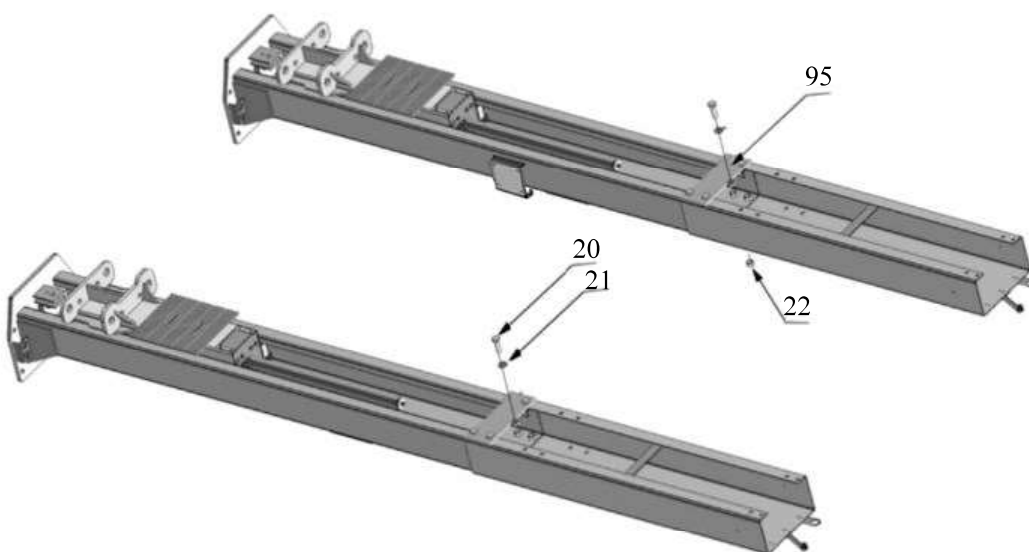

Fig. 18 High Setting

2. Low Setting: connecting the extension columns with the upper hole (See Fig.19).

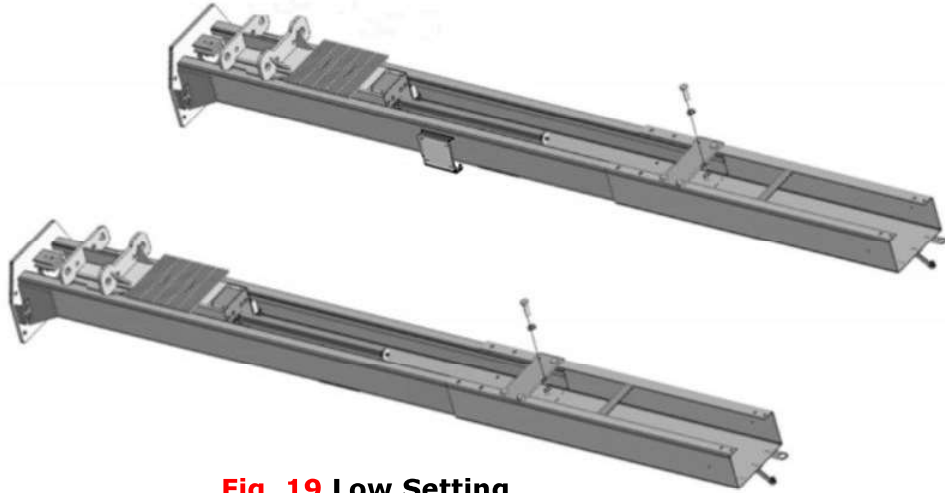
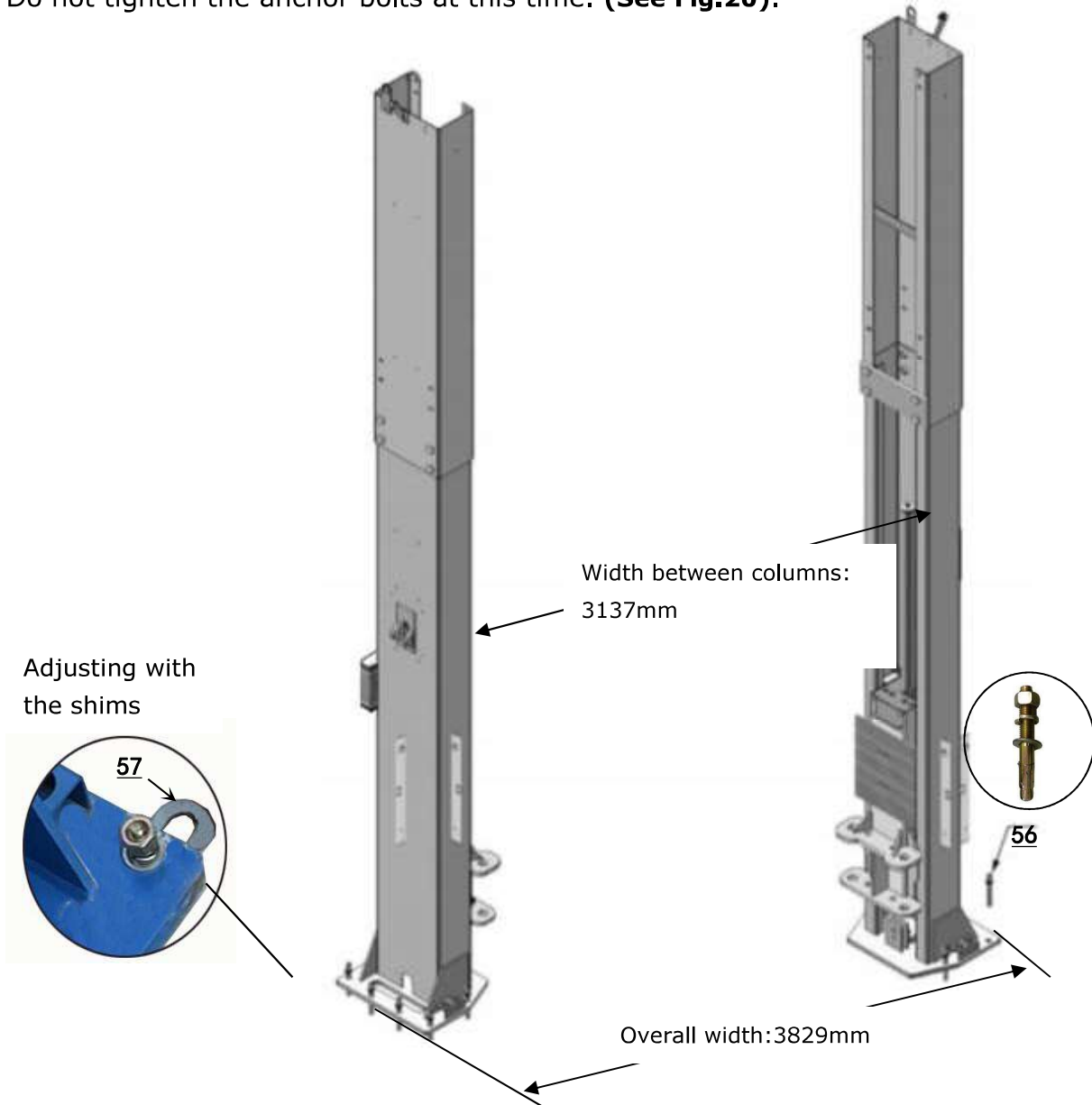

Fig. 19 Low Setting

G. Position the columns

Install anchor bolts. Position the columns on the installation layout. Check the columns verticality with level bar, and adjusting with the shims if the columns are not vertical. Do not tighten the anchor bolts at this time. (See Fig.20).



Note: Minimum embedment of Anchors is 115mm.

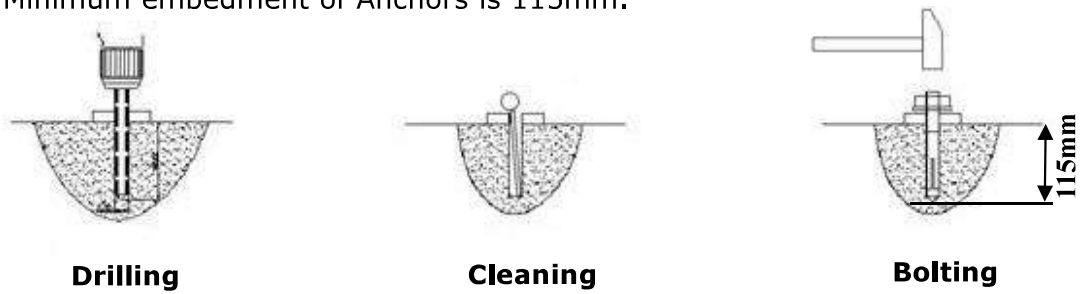

Fig. 20

H. Install overhead top beam

1. With help of the hook of top beam, put one side of top beam on top of the extension column and connecting the top beam to extension column by bolts, tighten the bolts. Then assemble the connecting bracket (**See Fig. 21**).

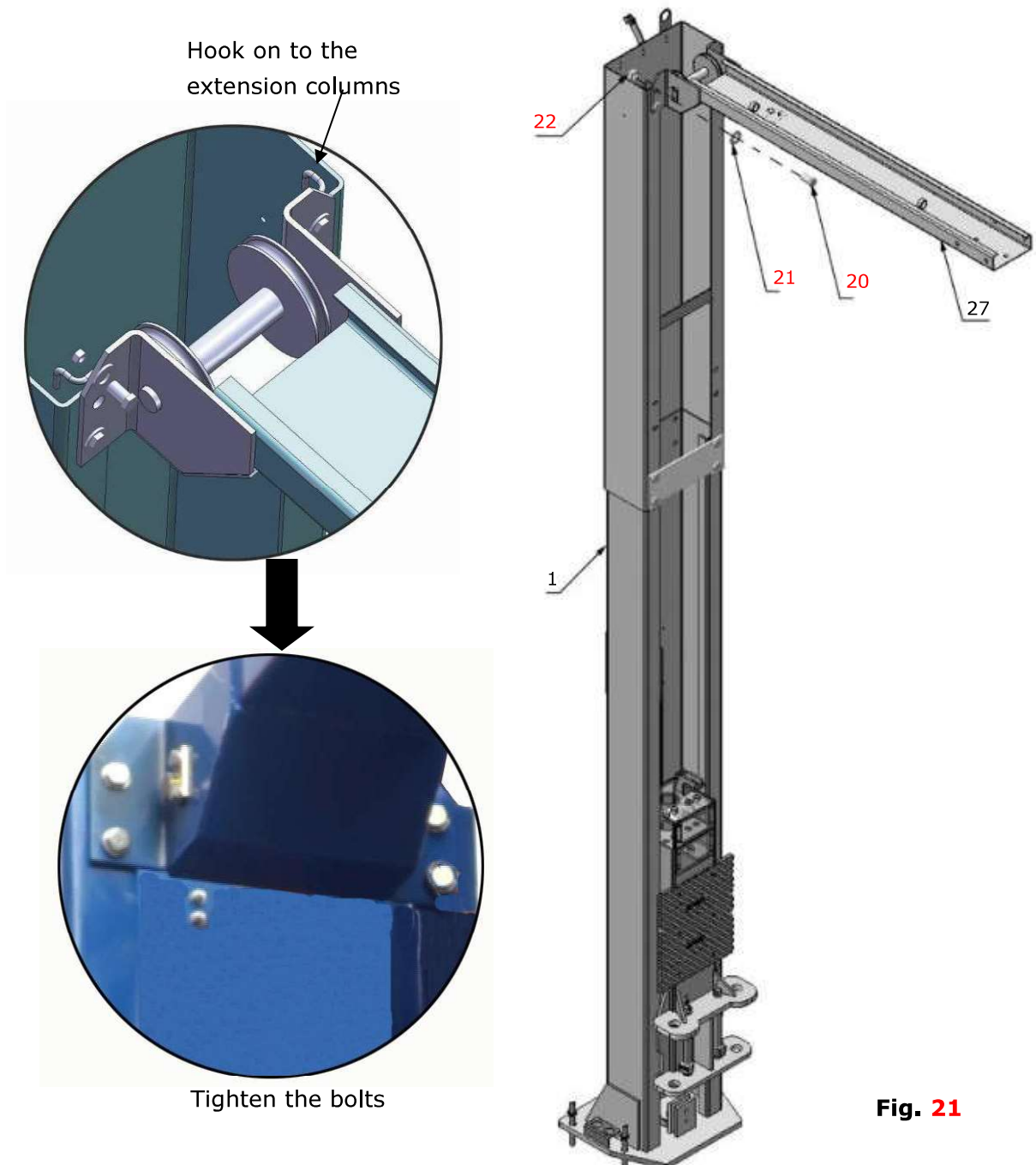

Fig. 21

2. Assemble overhead top beam, tighten the columns anchor bolts (**See Fig. 22**).

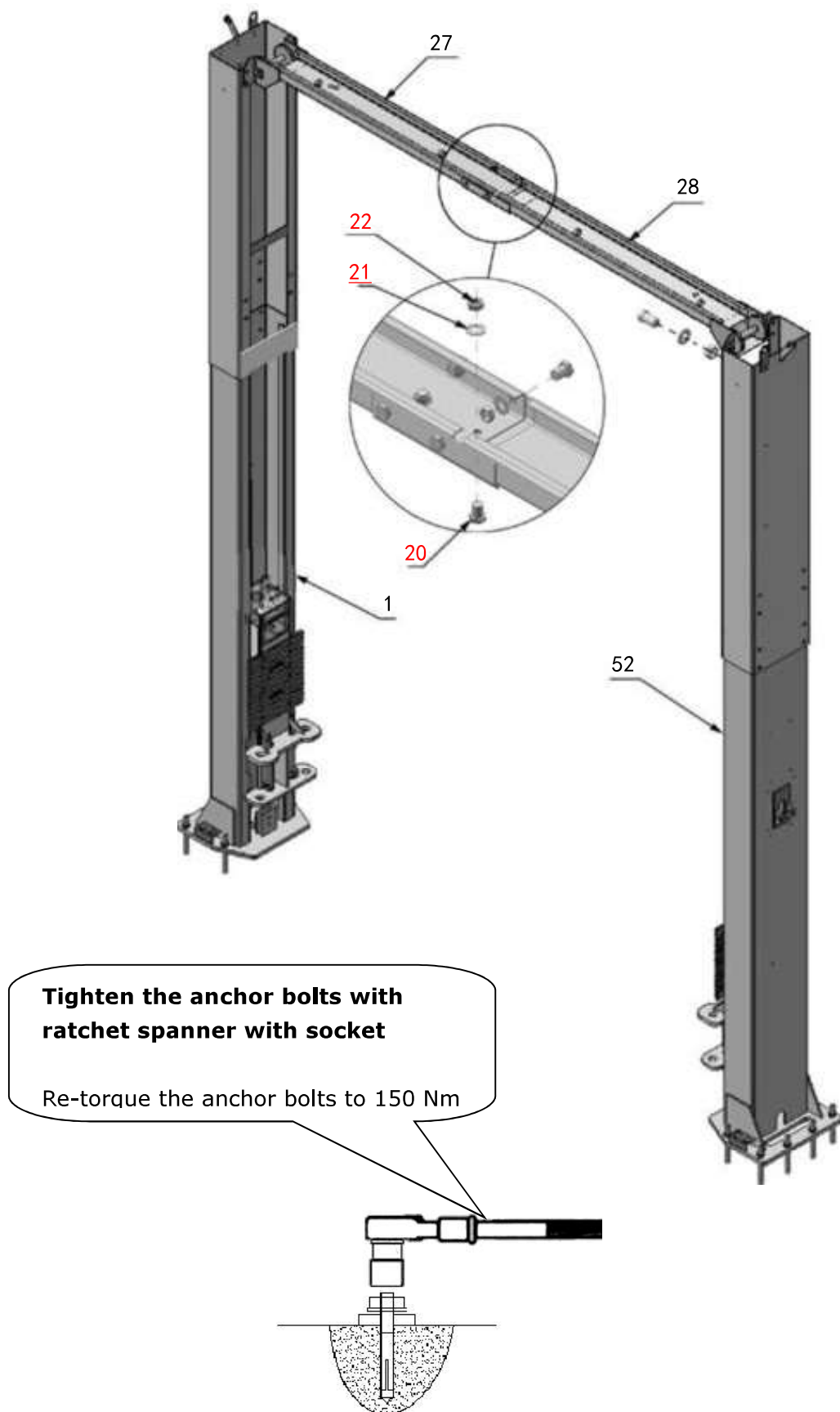

Fig. 22

I. Installing the limit control bar and limit switch (See Fig. 23).

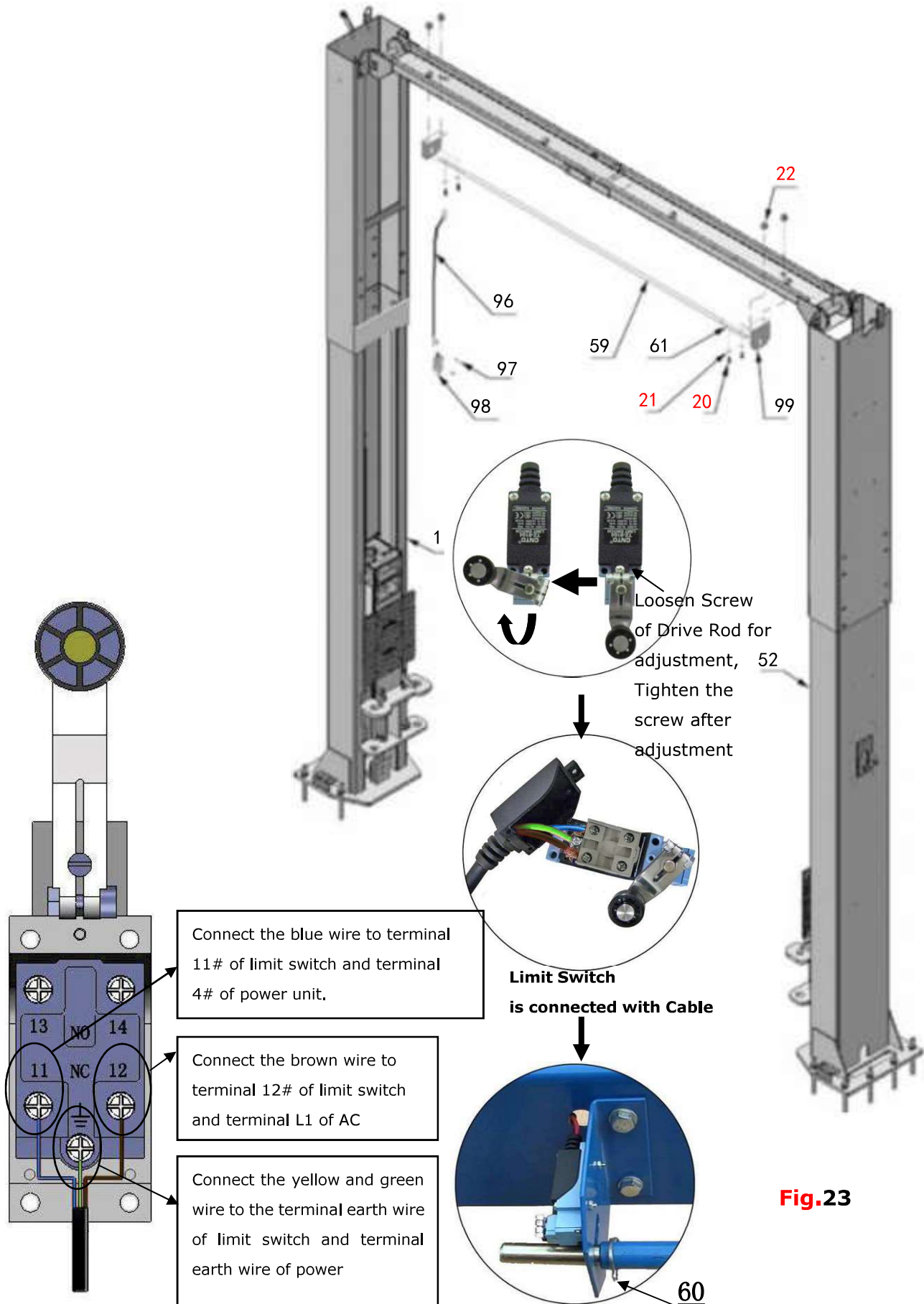

Fig.23

J. Install safety device (See Fig. 24 & Fig. 25).

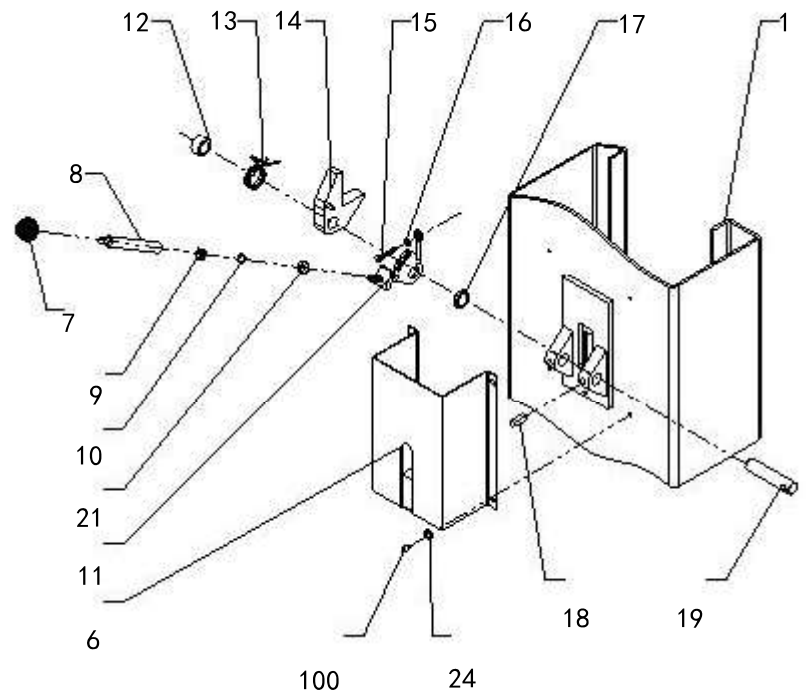
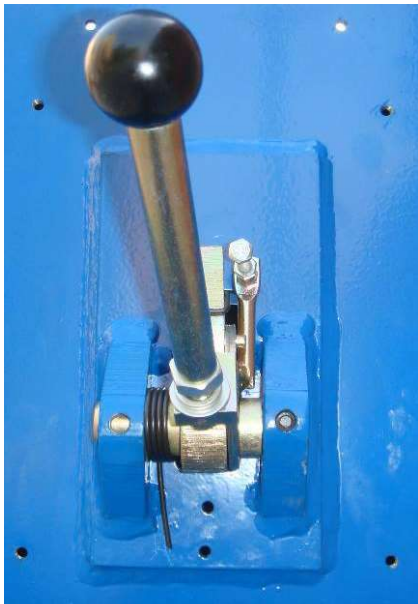

Fig. 24 Power-side safety device

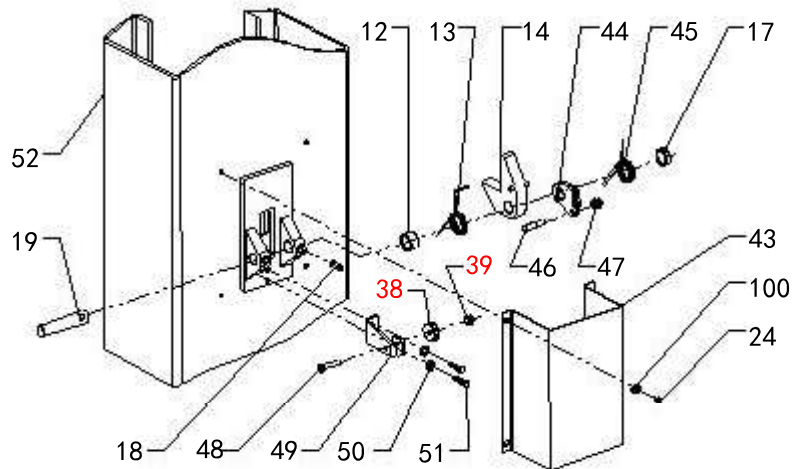

Fig. 25 Off-side safety device

K. Lift the carriages up by hand and make them be locked at the same level (**See Fig. 26**).

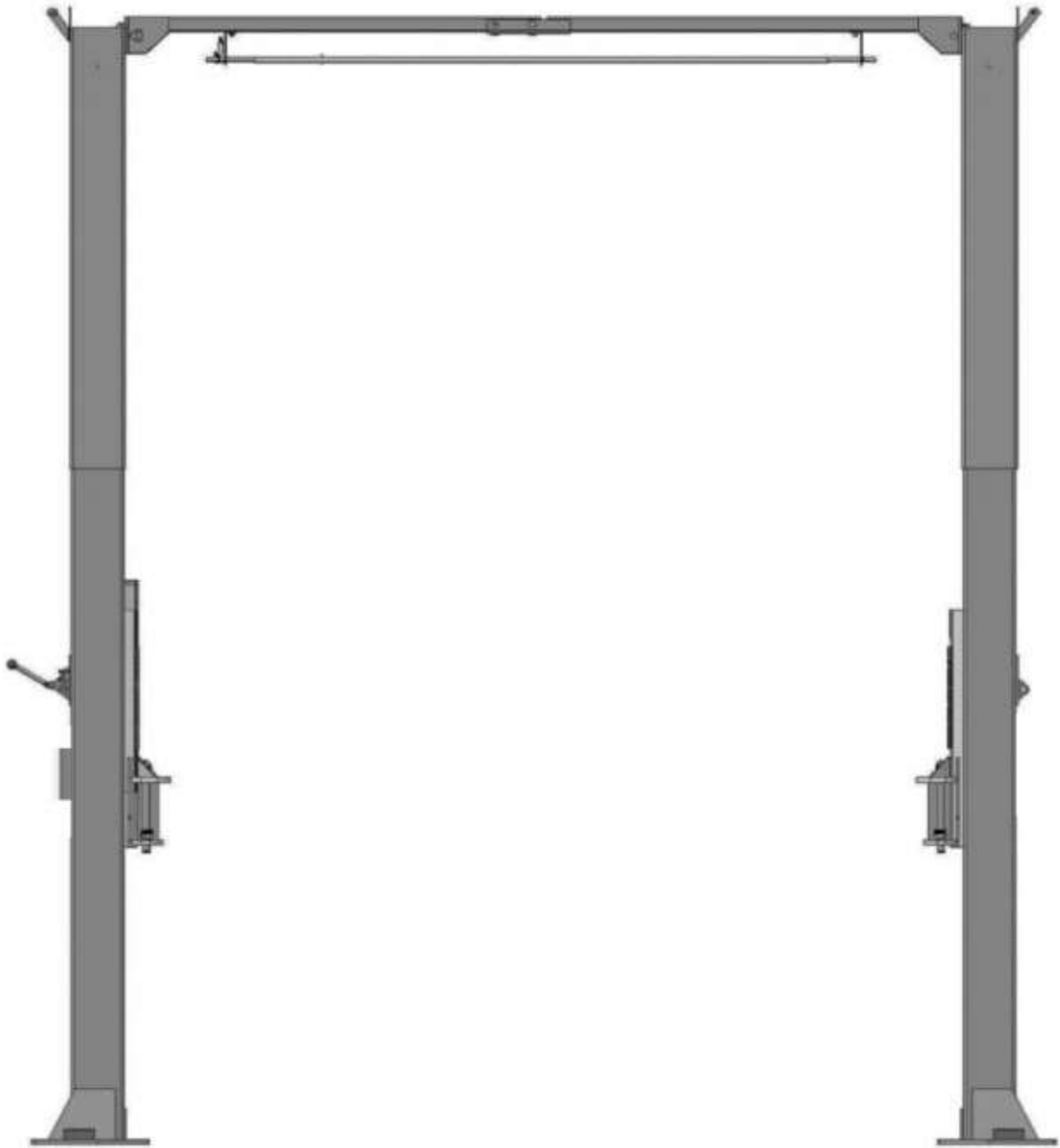

Fig. 26

L. Install cables

1. High setting cable connection

1.1 Take out the carriage plastic cover, cable pass through from the bottom of the carriage and be pulled out from the open of carriage, then screw the two cable nuts (See Fig. 27).

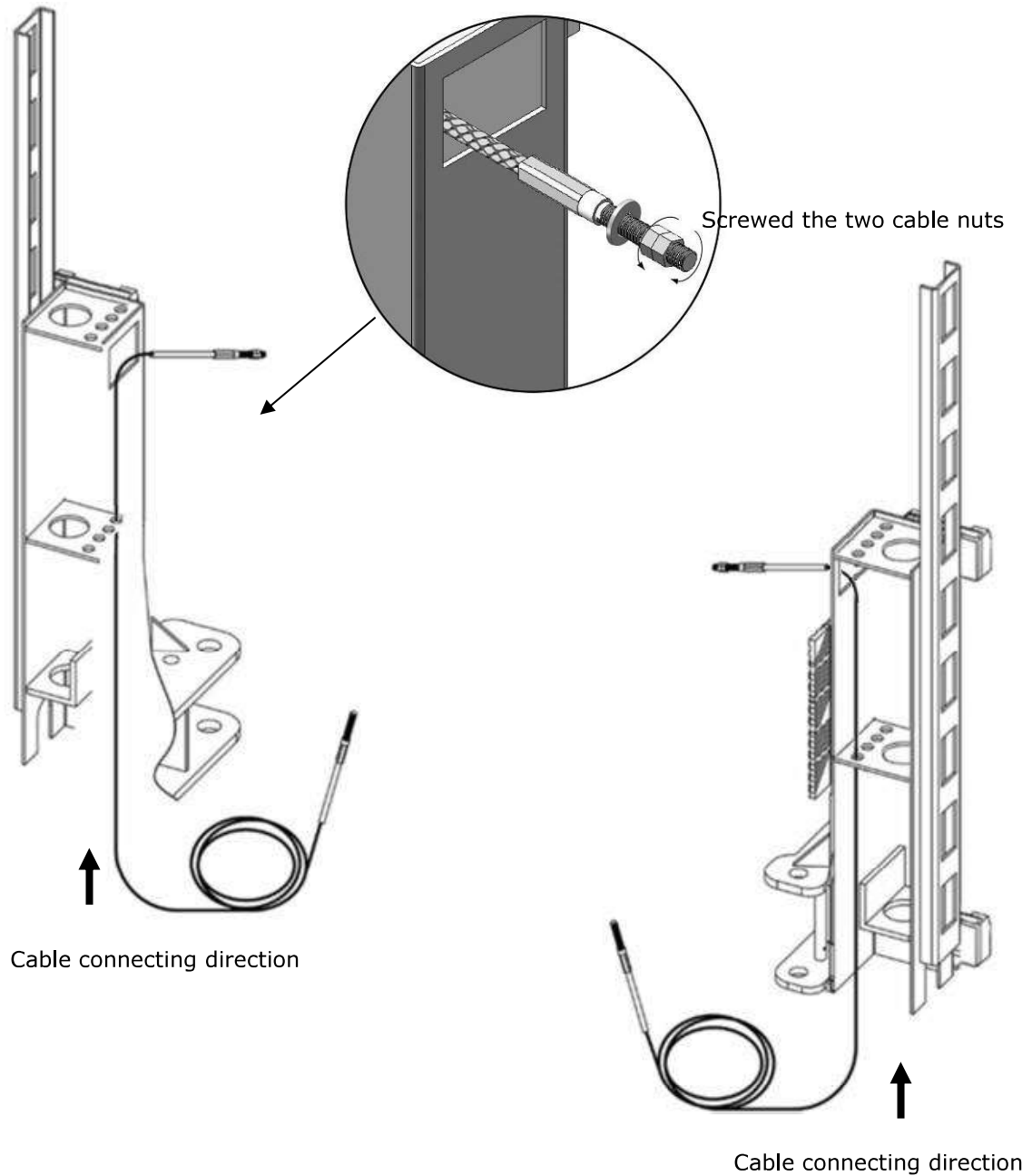

Fig. 27

1.2 Connecting cable for high setting (See Fig. 28)

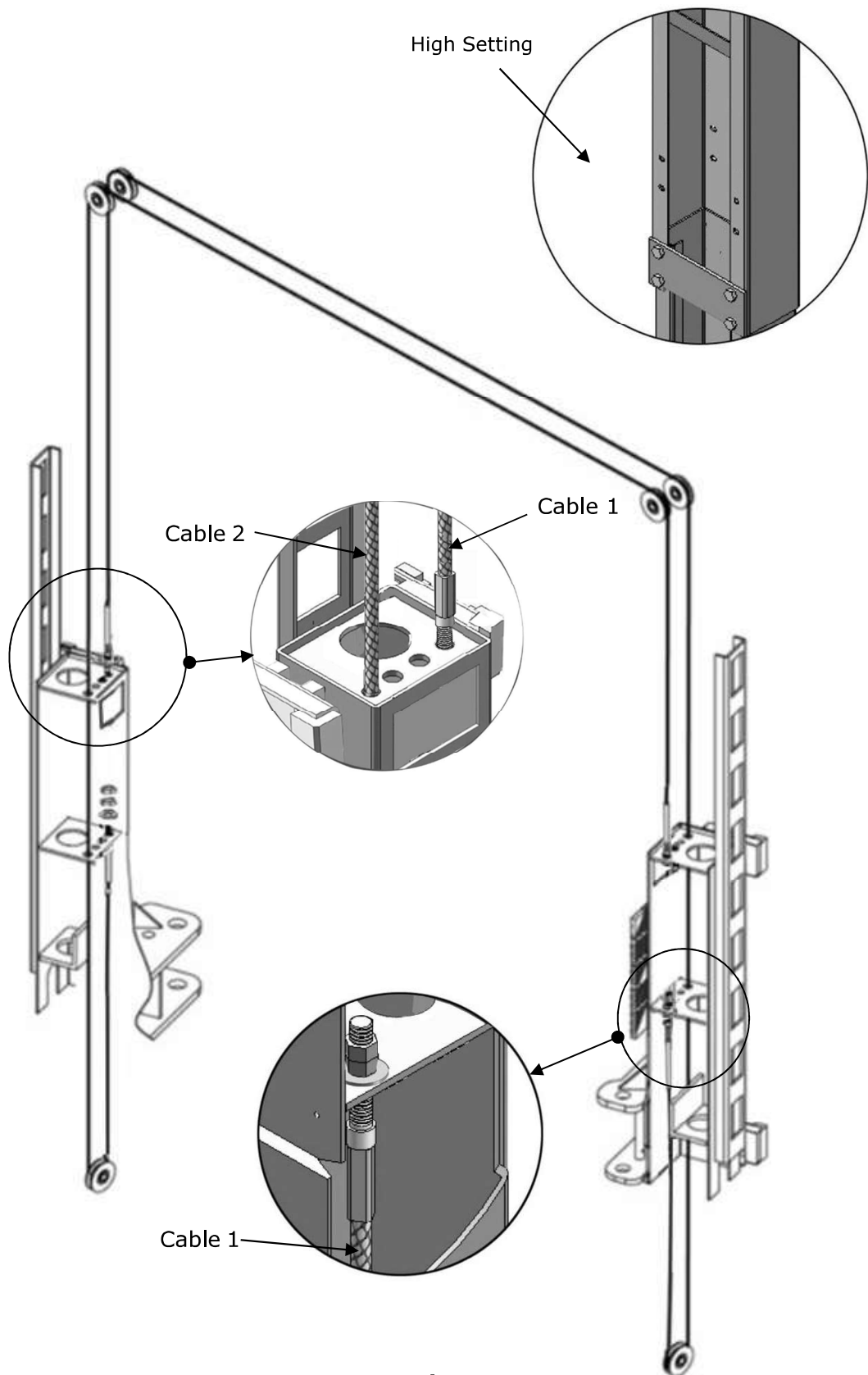

Fig.28

2. Low setting cable connection (See Fig. 29).

Note: Cable should go inside of the carriage.

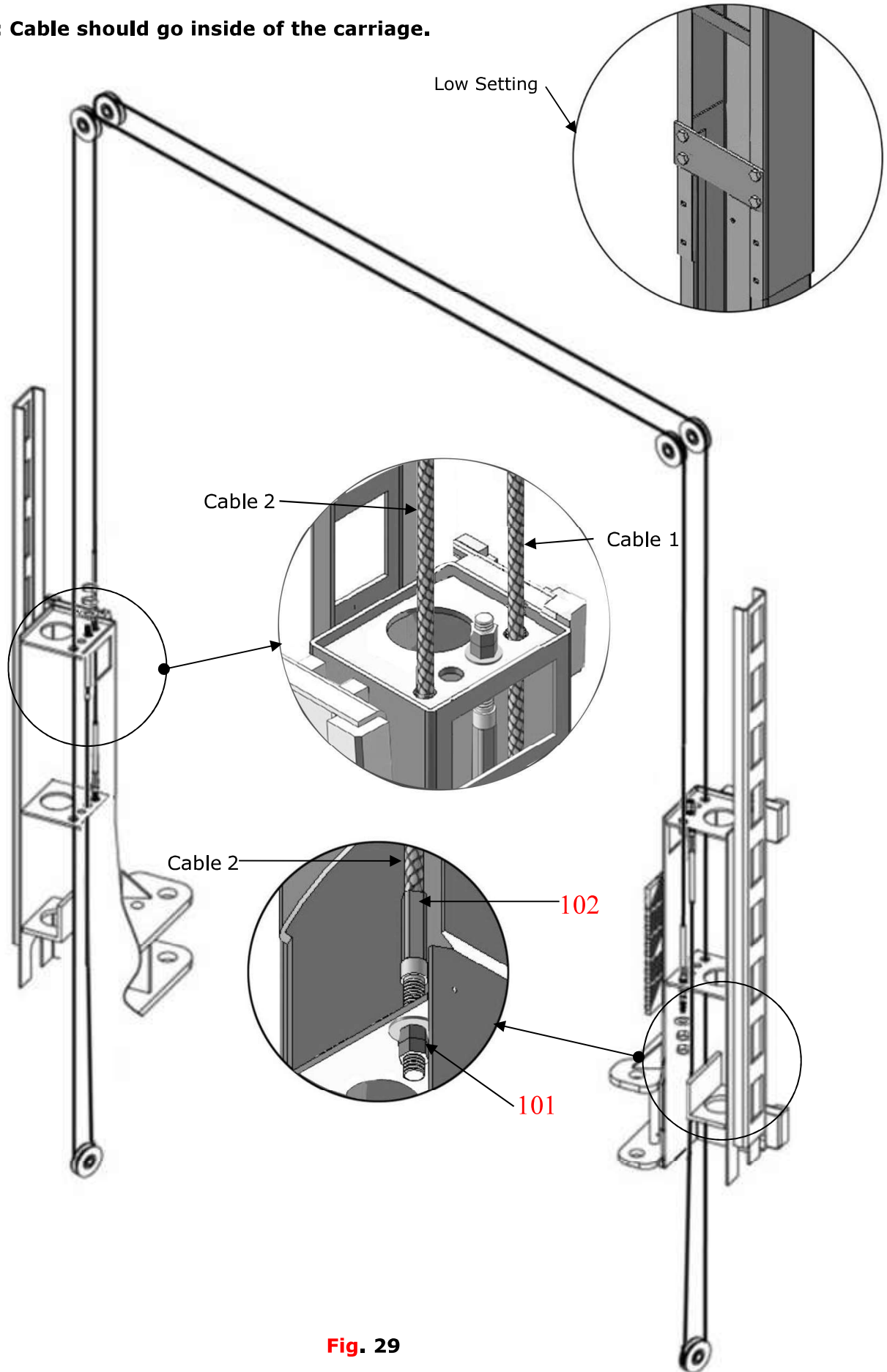

Fig. 29

M. Install power unit (See Fig. 30)

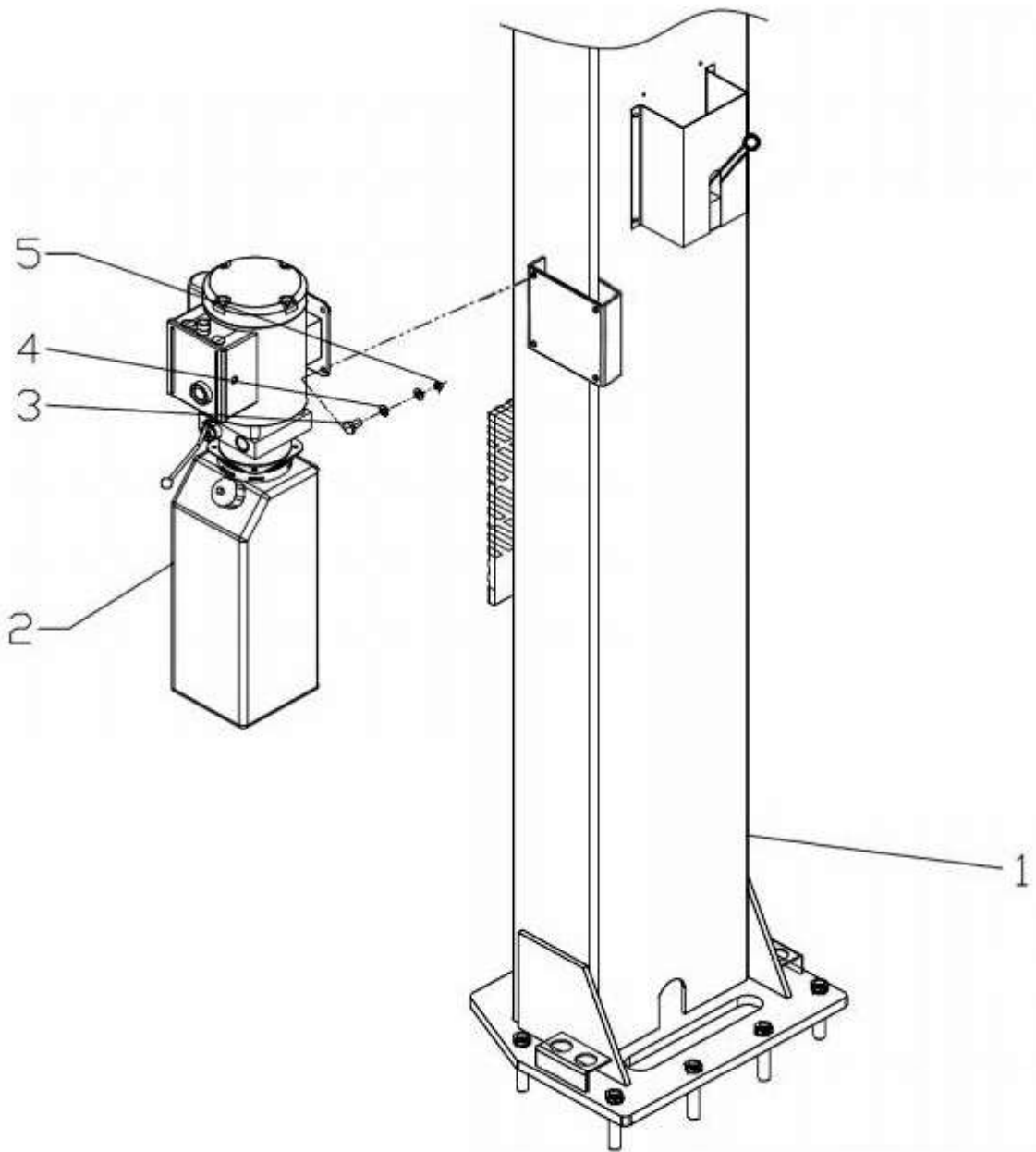

Fig. 30

Note: In consideration of Hydraulic Power Unit's durability and keep the equipment running in the perfect condition, please use Hydraulic Oil 46#.

N. Install oil hose

High setting and low setting oil hose installation (See Fig. 31).

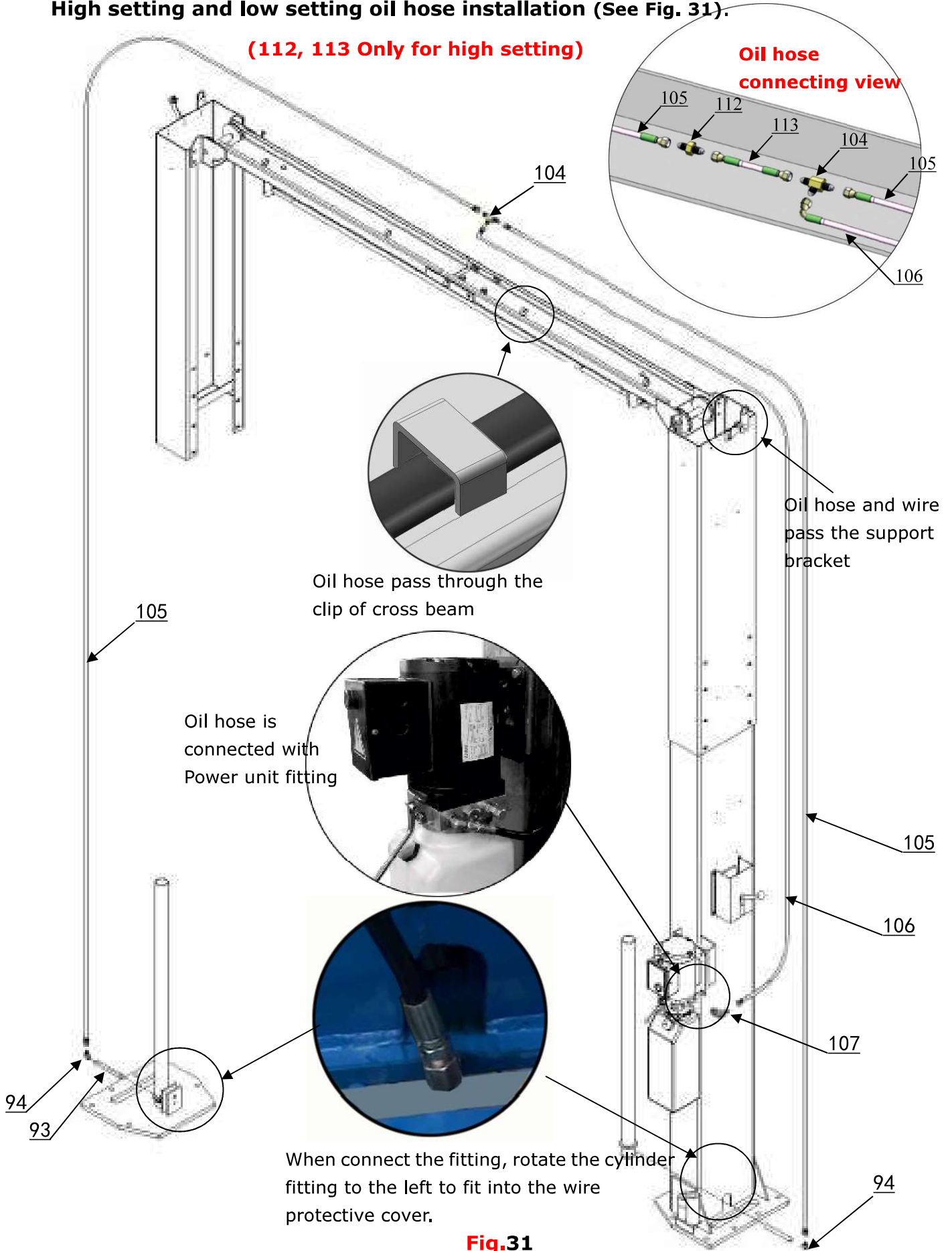

Fig.31

O. Install safety cable.

Install safety cable from off-side safety assy. to power-side safety assy., pass through the top beam bracket (See Fig. 32).

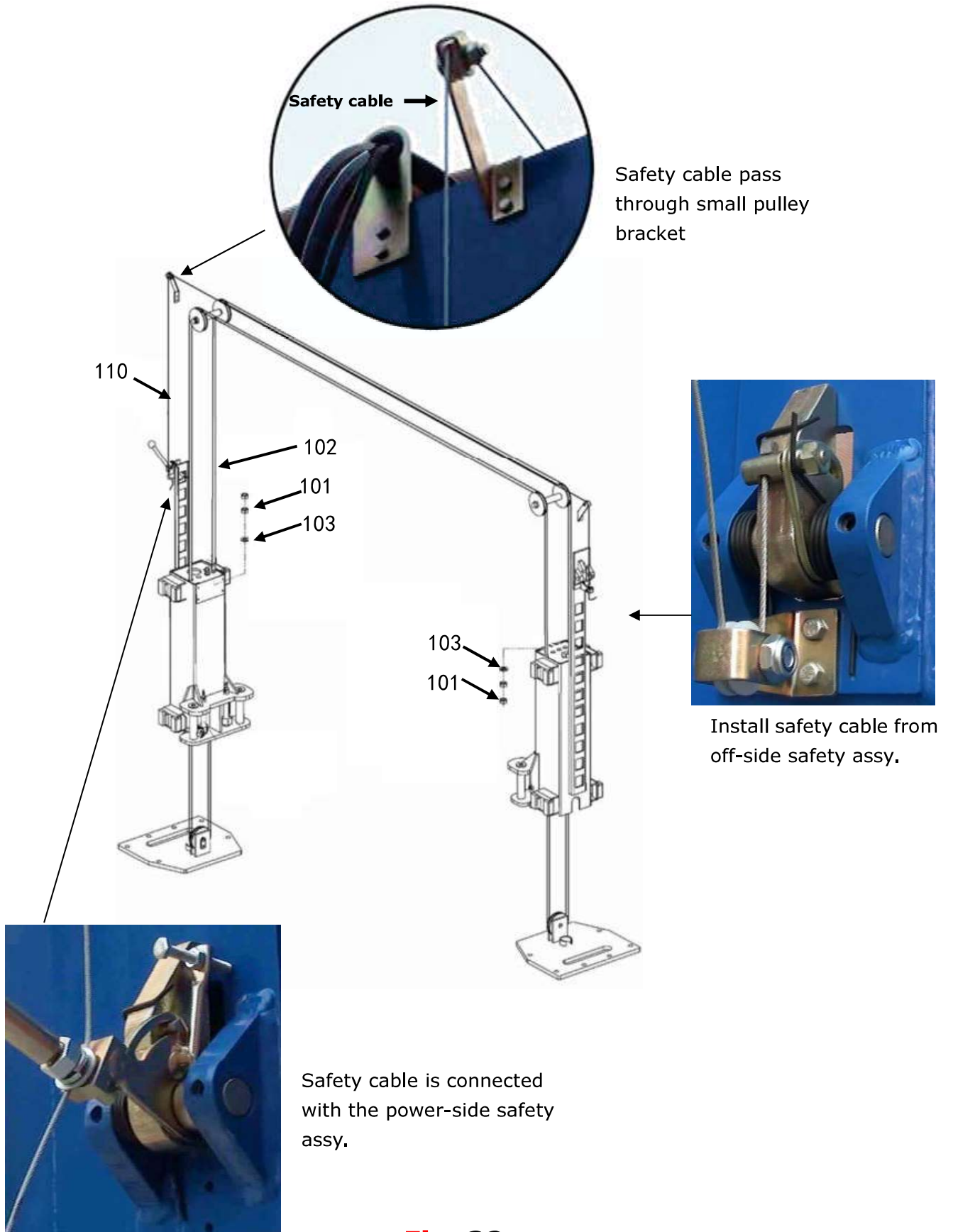

Fig. 32

P. Install wire protective cover (See Fig. 33).

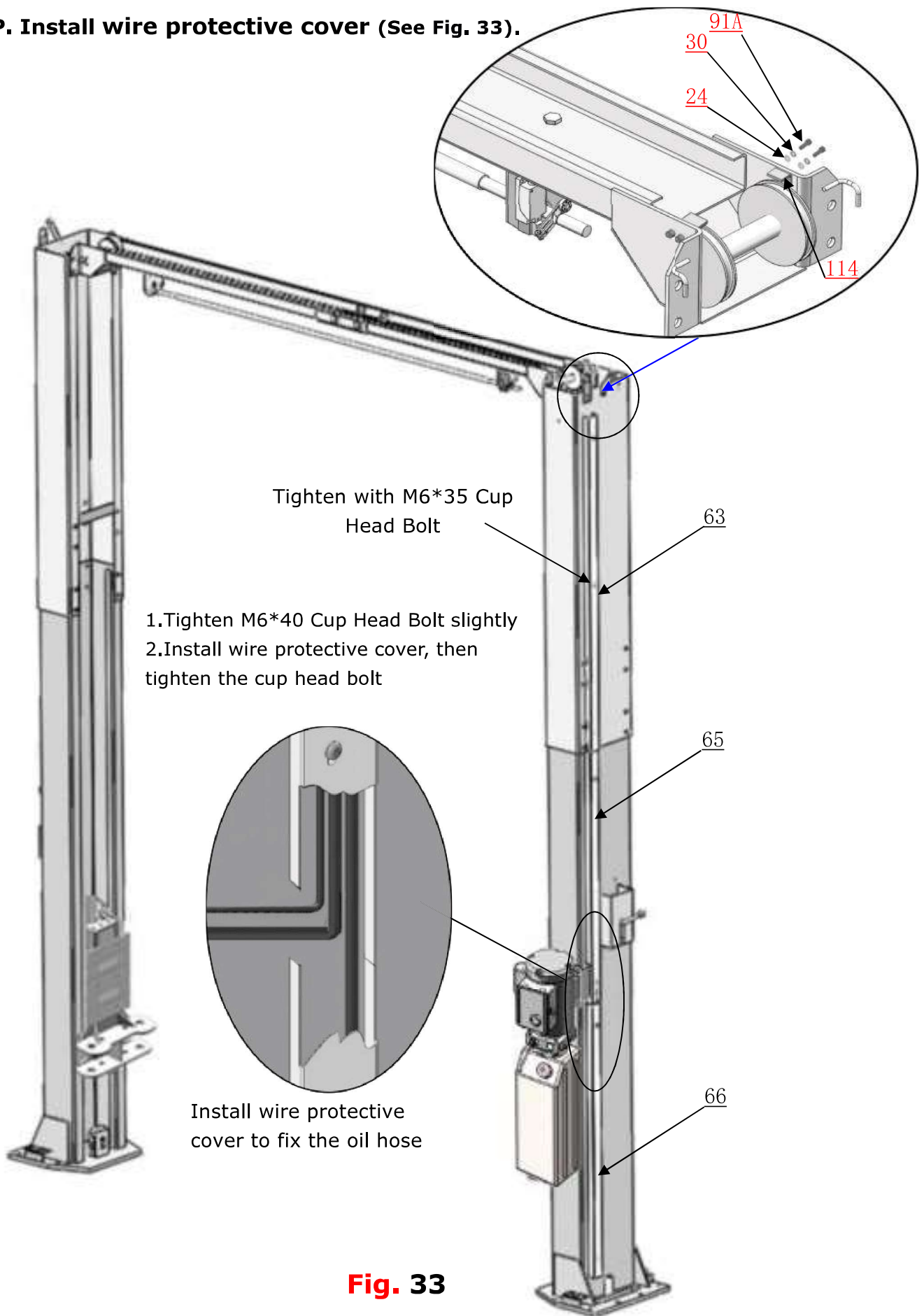
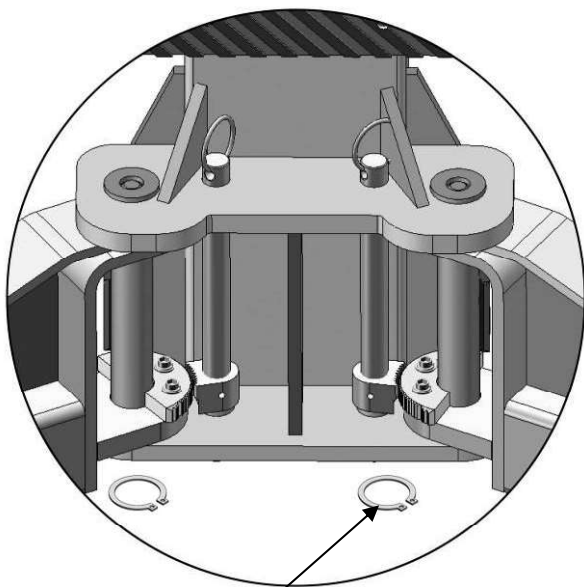

Fig. 33

Q. Install lifting arms and adjust the moon gears

1. Install lifting arms (**See Fig. 34**).
2. Lowering the carriages down to the lowest position, then use the 8# socket head wrench to loosen the socket bolt (**See Fig.35**).
3. Adjust moon gear as direction of arrow (**See Fig.36**).
4. Adjust the moon gear and arm lock to make it to be meshed, then tighten the socket bolts of arm lock (**See Fig.37**).



Snap Ring

**Install Lifting Arm
Fig.34**

Loosen the Socket Bolt

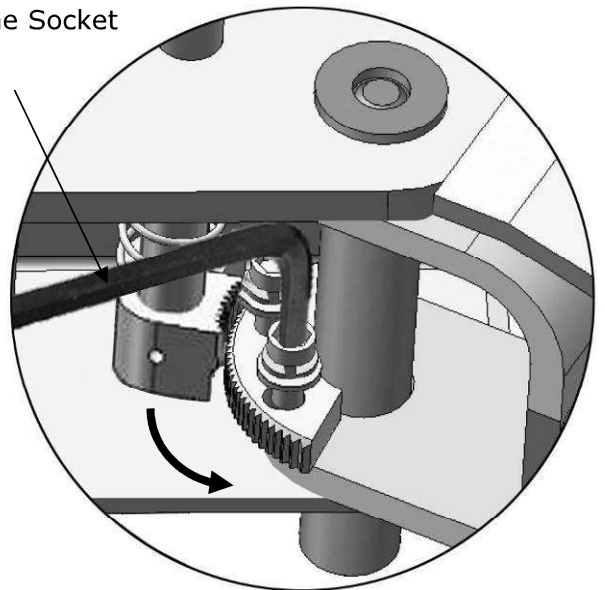

Use the 8# socket head wrench to loosen the socket bolt

Fig. 35

Moon Gear

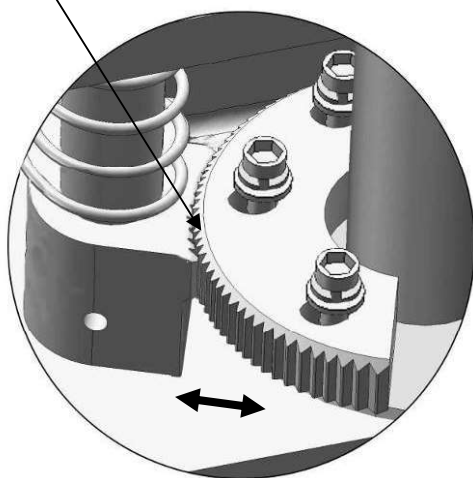

**Adjust moon gear
Fig.36**

Tighten socket bolt with wrench

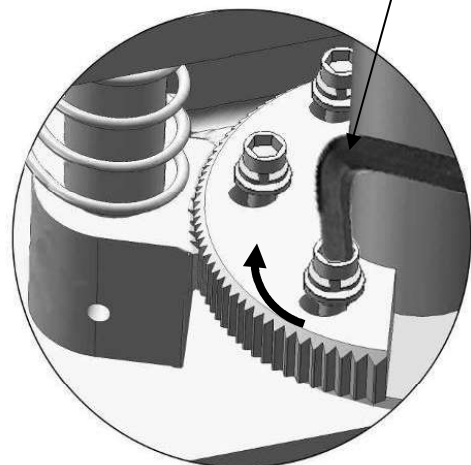

Locking the bolts after moon gear and arm lock engage well.

Fig.37

R. Tighten all the oil hose fitting, and fill the hydraulic oil. In consideration of Hydraulic Power Unit's durability and keep the equipment running in the perfect condition, please use Hydraulic Oil 46#.

S. Install electrical system

Connect the power source on the data plate of Power Unit.

- Note: 1. For the safety of operators, the power wiring must contact the floor well.**
- 2. Pay attention to the direction of rotations when using three phase motors.**

220V Single phase motor

1. Connecting the two power supply lines (fire wire **L** and zero wire **N**) to terminals of AC contactor marked **L1, L2** respectively.
2. Connecting the two power wire of Power unit to terminals of AC contactor marked T1,T2 respectively.
3. Connecting A2 terminal of AC contactor to L2 terminal with a single power supply line.
4. Connecting Limit switch: Remove the line of connecting terminal 4# of control button and A1 of AC contactor (**see Fig.38**) . Connecting wire 12#(brown wire) of limit switch with terminal 4# of control button ; Connect wire 11#(blue wire) with terminal A1# of AC contactor. Connecting the yellow and green wire to the terminal earth wire of limit switch and terminal earth wire of power unit. (**see Fig.39**)
5. Terminal #3 of the control button is connected with the terminal L1 of the AC contactor.

Circuit diagram

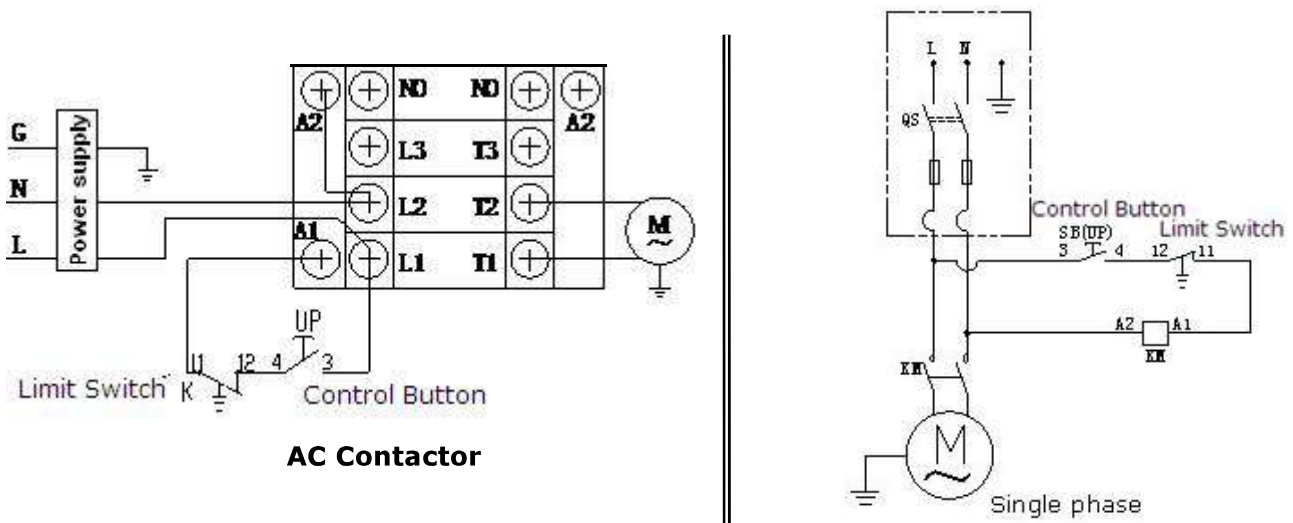

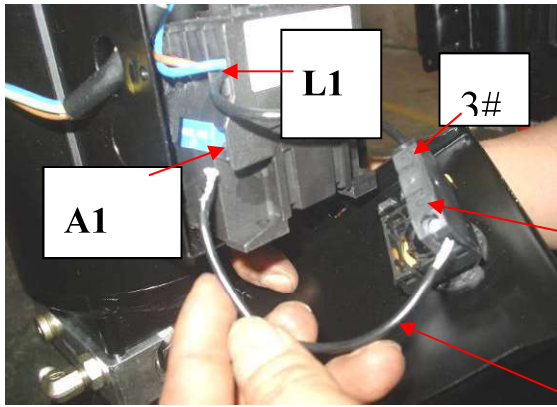

Motor Power Line
N
L

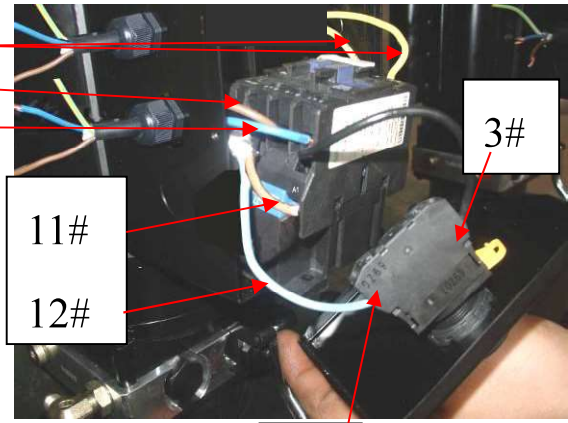

Remove this wire before connecting the Limit Switch

Fig. 38

Fig.39

Three phase motor

1. Circuit diagram (See Fig. 40)

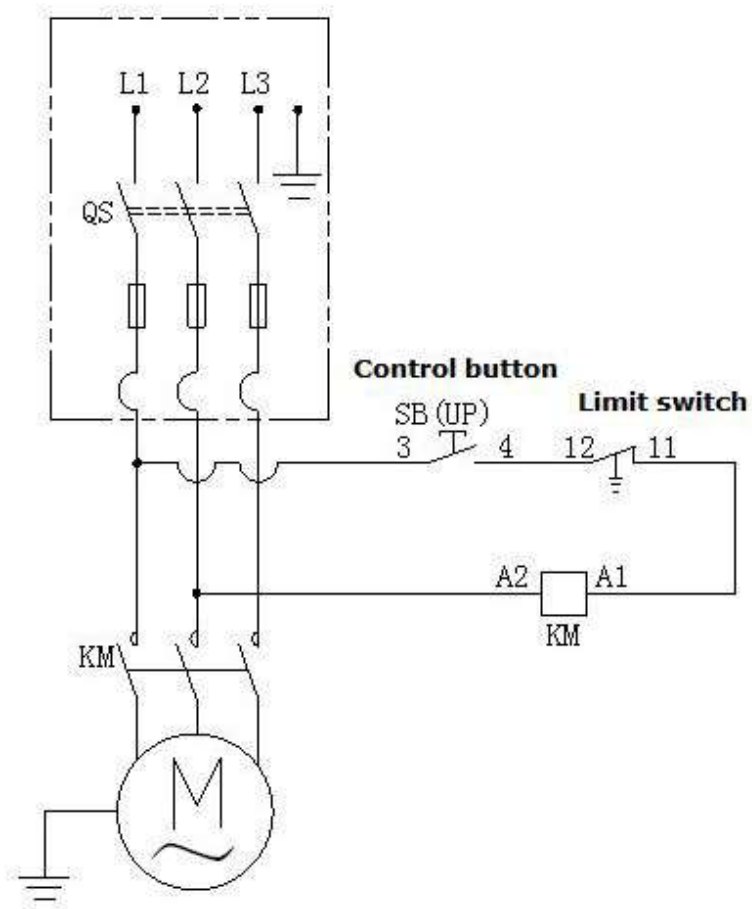
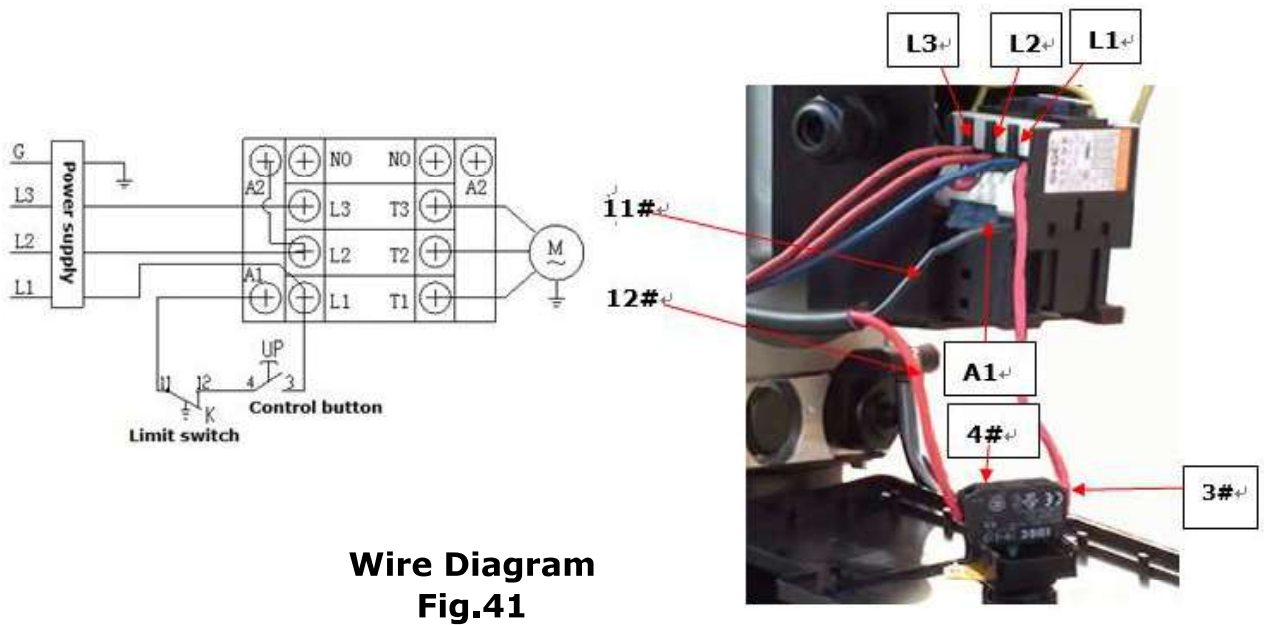

Fig.40

2. Connection step (See Fig. 41)

- a. The source wires (**L1, L2, L3**) are connected with terminals of AC contactor marked **L1, L2, L3** respectively.
- b. Wire **12#** (brown wire) of limit switch is connected with Terminals **4#** of control button; wire **11#**(blue wire) is connected with **A1** terminal of AC contactor, Earth wire(yellow and green wire) of limit switch is connected with the earth wire terminal of the motor.
- C. Terminals **3#** of control button is connected with **L1** terminals of AC contactor.



IV. EXPLODED VIEW

Model CL5500C

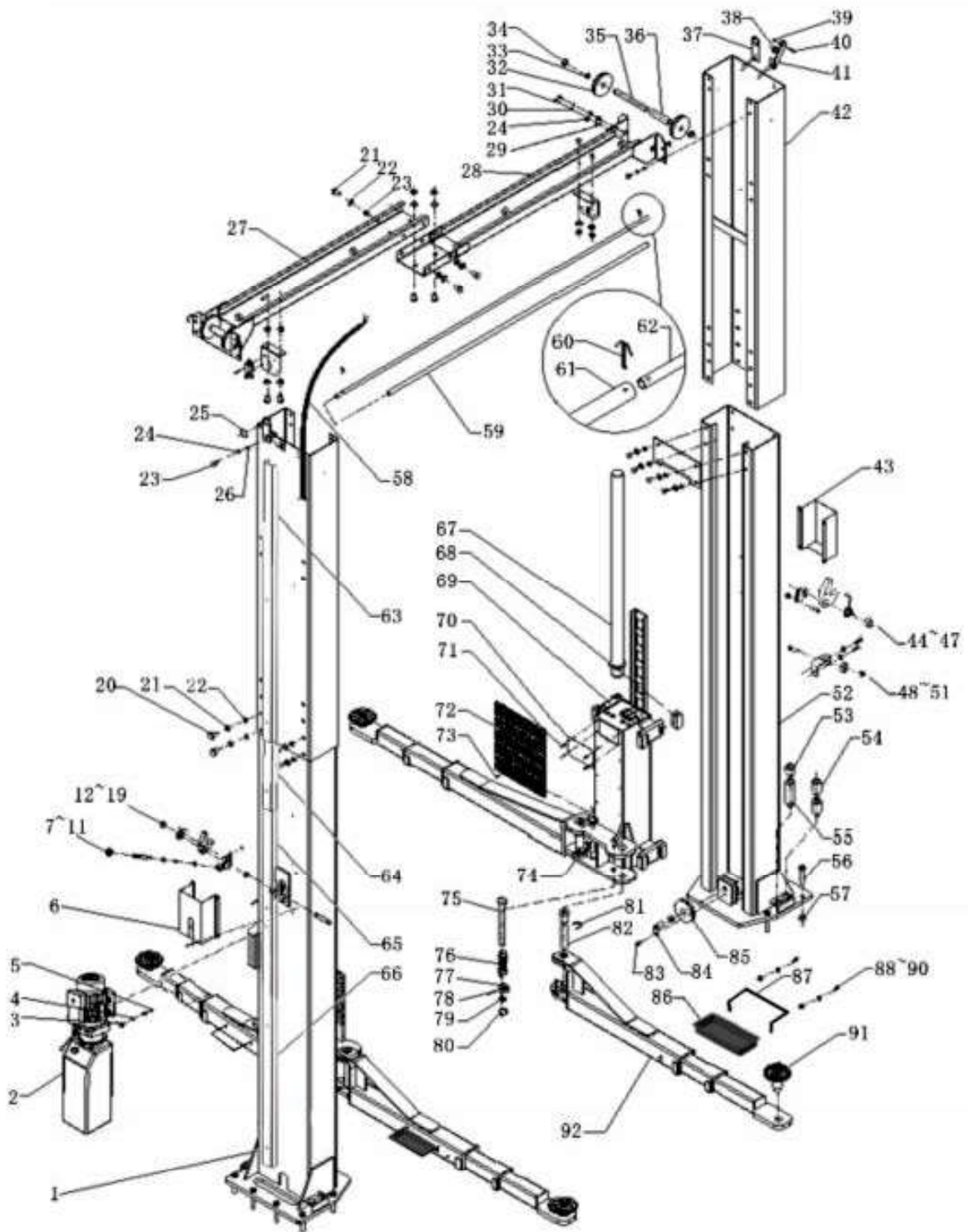

Fig.42

Parts list

Item	Part#	Description	Qty
1	11217458	Power-side column	1
2	81513003	Power unit	1
3	10209003	Hex Bolt	4
4	10209033	Washer	4
5	10217002	M8 Hex Nut	4
6	11217405	Power-side safety cover	1
7	11217005	Plastic Ball	1
8	11217006	Lock handle	1
9	10206023A	Hex Nut	1
10	10420026	Lock Washer	1
11	11217004	Main cam lock	1
12	11217007	Large spacer	2
13	10217030	Main spring	2
14	11217009	Main lock	1
15	10217010	Hex Bolt	1
16	11217011	Hex Nut	1
17	11217012	Large spacer	2
18	10217051	Socket Bolt	2
19	11217050	Main Lock Pin	2
20	11217069	Hex Bolt	34
21	10206006	Washer	35
22	10206023	Nylok nut	34
23	10420018	Nylok nut	8
24	10420045	Washer	38
25	1061K074	Protective ring	2
26	10217013	Hex Bolt	8
27	11217016B	Top Beam Assy. (Left)	1
28	11217015B	Top Beam Assy. (Right)	1
29	11420044	Limit Plate	2
30	10209149	Lock Washer	12
31	10420138	Socket Bolt	4
32	11217019	Top Pulley	4
33	10217020	Bronze bush for pulley	6
34	11217021	Top Pulley Spacer (Short)	4
35	11217022	Pin for Top Pulley	2
36	11217023	Pin Spacer (Long)	2
37	11217024	Oil Hose Support Plate	2
38	10206009	Plastic Small Pulley	3
39	10209056	Nylok nut	3
40	10209046	Hex Bolt	3
41	11217026	Safety Cable Bracket	2
42	11217470	Outer Column	2

Item	Part#	Description	Qty
43	11217406	Off-side safety cover	1
44	11217031	Off-side cam Lock	1
45	10217008	Safety Spring	1
46	10217032	Cable lock hold	1
47	10217033	Self locking Nut	1
48	10209056	M10 Self locking Nut	3
49	10206009	Plastic Small Pulley	3
50	11217029	Small Pulley Bracket	1
51	10217066	Hex Bolt	3
52	11217459	Off-side Column	1
53	11209051B	Adapter 1.5"	4
54	11209052B	Adapter 2.5"	4
55	11209053B	Adapter 5"	4
56	10207045	Anchor bolt	12
57	10620065	Shim(2mm)	10
	10201090	Shim(1mm)	10
58	10217173	Wire Cable L=4856	1
59	10206025A	Foam Cushion	1
60	10201005	Split Pin	2
61	11206129	Control Bar L=2400mm	1
62	11206025C	Control bar of connecting pin	2
63	11217478	Wire Protective cover	2
64	10206110	M6*35 Cup head Bolt	6
	10206079	M6*40 Cup head Bolt	10
65	11217473	Wire Protective cover (High setting)	2
	11217477	Wire Protective cover (Low setting)	2
66	11217880	Wire Protective cover 1320mm	1
	11217895	Wire Protective cover 1320mm	1
67	10217056A	Cylinder	2
68	10217188	Slider block	16
69	11217479	Carriage	2
70	11217054	Carriage Plastic Cover	2
71	10209009	Cup Head Bolt	8
72	10217053	Protective Rubber	2
73	10209019	Flat Head Screw	12
74	11217046B	Arm Lock Bar(Right)	2
75	11217046C	Arm Lock Bar(left)	2
76	10217045A	Spring	4
77	10217044	Arm Lock	4
78	10206036	Hair pin	4
79	10640109	Washer	8
80	10206032	Snap Ring	4
81	10520023	Snap Ring	4
82	11217047B	Arm Pin	4

Item	Part#	Description	Qty
83	10209038	Hex Bolt	6
84	11217037	Bottom pulley Pin	2
85	11217036	Bottom Pulley	2
86	10206156	Tool tray	2
87	11206154	Rear guard bar	4
88	10201002	Hex bolt	8
89	10209034	Lock Washer	8
90	10209033	Washer	8
91	10217114A	Rubber pad assy.	4
91A	10420138	Socket bolt	12
91B	10209134	Rubber Pad	4
91C	11680030B	Rubber Pad Frame	4
92	10217327	Lifting Arm Assy.	4
93	11217060A	Extend Straight Fitting	2
94	10217061A	90° Fitting	2
95	11217068	Column Reinforce Plate	2
96	10217454	Wire Cable	1
97	10206011	Cup Head Bolt	2
98	10206013	Limit switch	1
99	11206042	Limit Bar Bracket	2
100	10209009	Cup Head Bolt	8
101	10209066	Cable nut M16	8
102	10217452	Cable Assy.	2
103	10420029	Cable shim	4
104	10217195	T-Fitting	1
105	10217455	Oil hose Assy.	2
106	10217456	Oil hose Assy.	1
107	10217189	90° fitting for power unit	1
108	10206110	Cup Head Bolt	6
109	10206079	Cup Head Bolt	12
110	10217453	Safety Cable	1
111	10217501B	Parts box	1
112	1002185002	Straight Fitting (High setting)	1
113	1002185001	Oil Hose 3/8"*1218mm (High setting)	1
114	1102075001	Cable restrain plate	4

4.1. Lifting Arm (10217327)

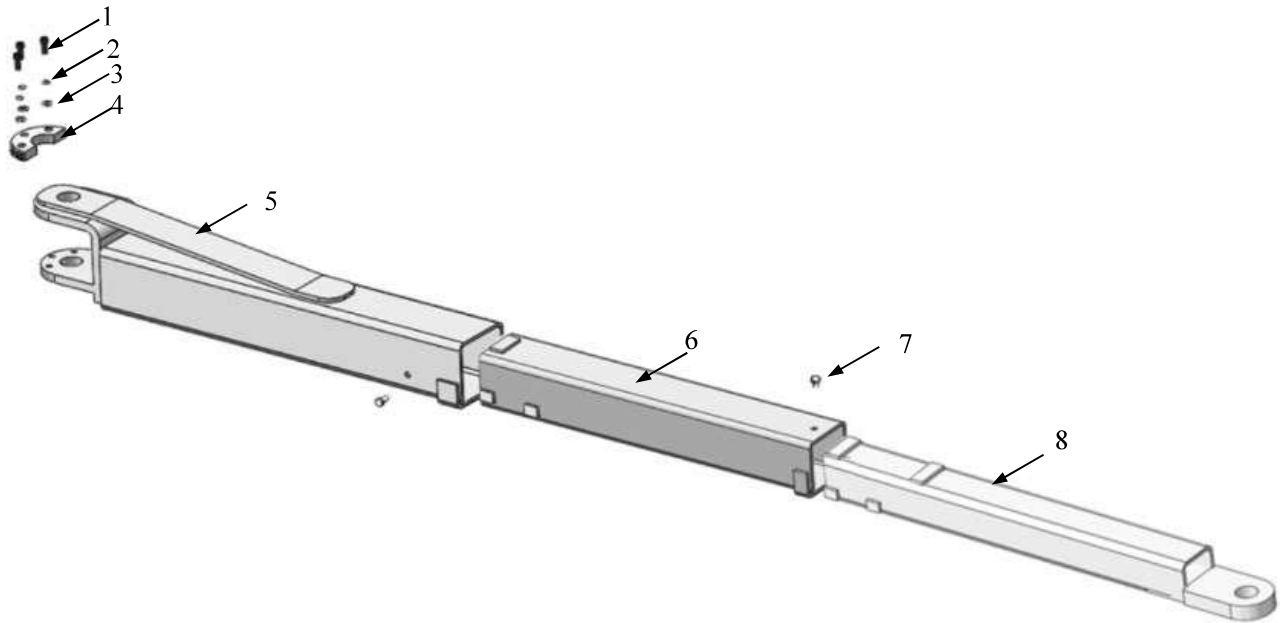

Fig.43

Item	Part#	Description	Qty.	Note
1	10206048	Socket bolt	12	
2	10209039	Lock washer	12	
3	10209022	Washer	12	
4	11206049	Moon Gear	4	
5	11217834	Outer Arm	4	
6	11217337	Middle Arm	4	
7	10201149	Flat Head Screw	8	
8	11217336	Inner Arm	4	

4.2 Cylinders (10217056A)

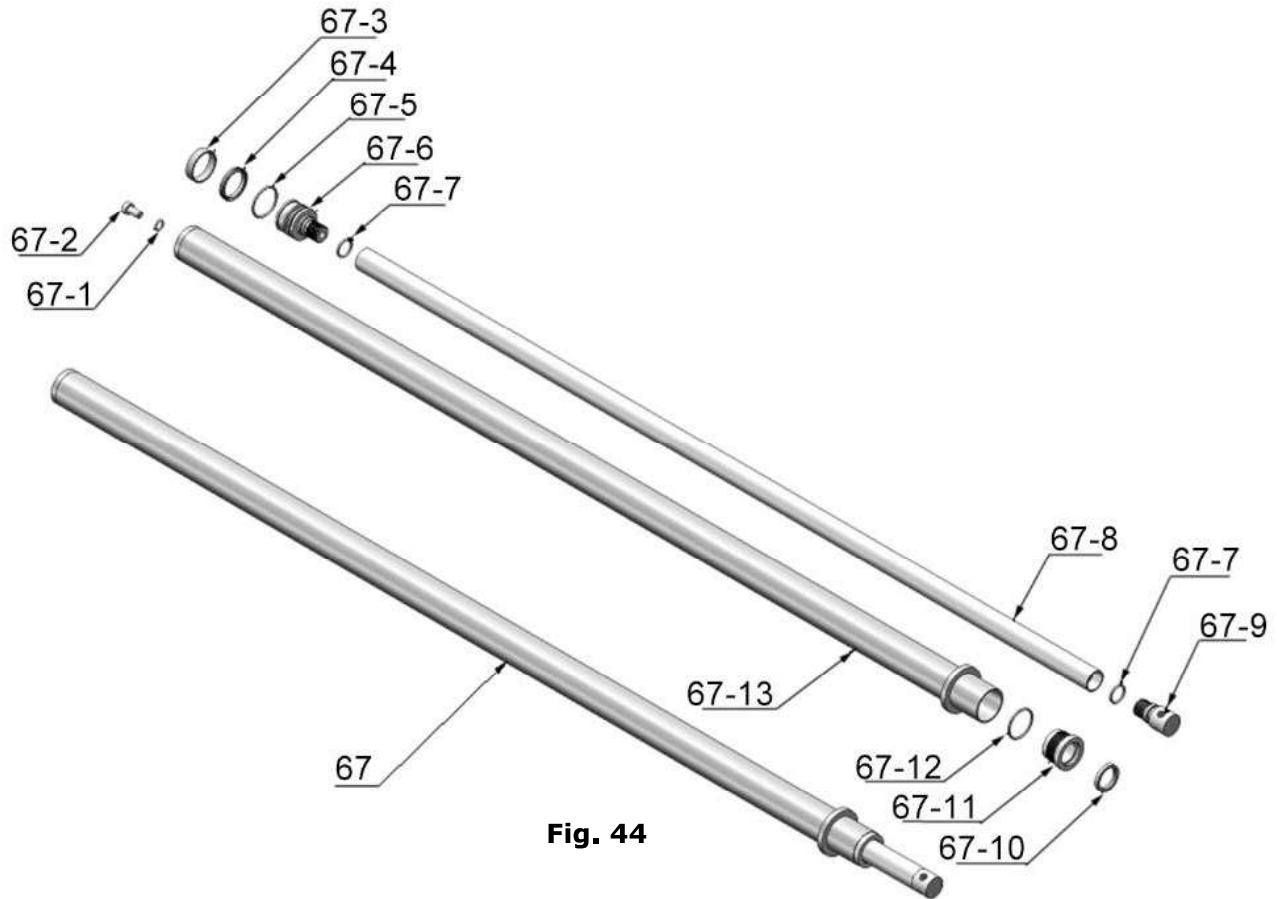

Fig. 44

Parts list for Cylinder

Item	Part#	Description	Qty.	Note
67-1	10209069	O-Ring	2	
67-2	10209070	Bleeding Plug	2	
67-3	10217071	Support Ring	2	
67-4	10217072	Y-Ring OSI	2	
67-5	10217073	O-Ring	2	
67-6	11217074	Piston	2	
67-7	10217075	O-Ring	2	
67-8	11217089	Piston rod	2	
67-9	11217077	Piston rod fitting	2	
67-10	10217078	Dust Ring	2	
67-11	11217079A	Head Cap	2	
67-12	10217080A	O-Ring	2	
67-13	11217090	Bore weldment	2	

4.3. Manual Power unit (81513003/81513004)

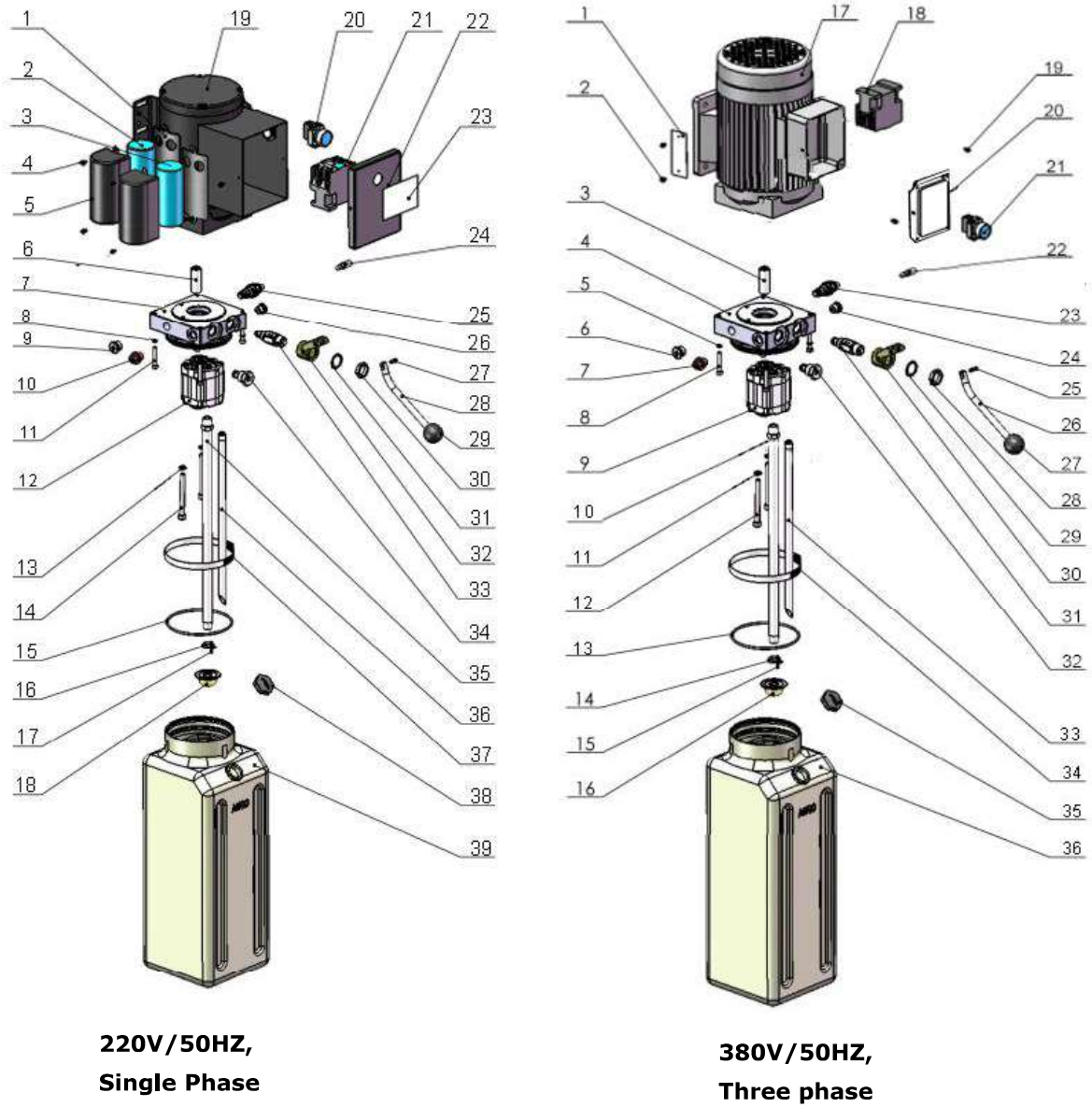

Fig.45

Manual Power Unit, 220V/50Hz, Single phase

Item	Part#	Description	Qty.	Note
1	81400180	Rubber Pad	2	
2	81400250	Start Capacitor	1	
3	81400200	Run Capacitor	1	
4	10420148	Cup Head Bolt with Washer	6	
5	81400066	Capacitor Protective Cap	2	
6	81400363	Motor Connecting Shaft	1	
7	80101013	Manifold Block	1	
8	10209149	Lock Washer	4	
9	81400276	Iron Plug	1	
10	81400259	Plastic Red Plug	1	
11	85090142	Socket bolt	4	
12	81400158	Gear Pump	1	
13	10209034	Lock Washer	2	
14	81400295	Socket bolt	2	
15	81400365	O-ring	1	
16	10209152	Ties	1	
17	85090167	Magnet	1	
18	81400290	Fliter	1	
19	81400413	Steel Motor	1	
20	10420070	Switch	1	
21	41030055	AC connector	1	
22	81400528	Cover of Motor Terminal Box	1	
23	71111171	AMGO Name Plate	1	
24	81400560	Throttle Valve	1	
25	81400266	Relief Valve	1	
26	81400284	Iron Plug	1	
27	10720118	Hair pin	1	
28	81400451	Handle For Release Valve	1	
29	10209020	Plastic ball	1	
30	81400421	Nut for release valve	1	
31	81400422	Self locking flat pad	1	
32	81400447	Valve seat(low)	1	
33	81400567	Release valve(low)	1	
34	81400560	Check valve	1	
35	81400366	Inlet pipe	1	
36	81400367	Oil return pipe	1	
37	81400364	Hose clamp	1	
38	81400263	Filler cap	1	
39	81400319	Reservoir	1	

Manual Power Unit 380V/50Hz, Three phase

Item	Part#	Description	Qty.	Note
1	71150022	AMGO Name plate	1	
2	81400300	Cup Head Bolt	2	
3	81400363	Motor Connecting Shaft	1	
4	80101013	Manifold block	1	
5	10209149	Washer	4	
6	81400276	Iron plug	1	
7	81400259	Red rubber plug	1	
8	85090142	Socket bolt	4	
9	81400307	Gear pump	1	
10	81400366	Inlet pipe	1	
11	10209034	Washer	2	
12	81400295	Socket bolt	2	
13	81400365	O ring	1	
14	10209152	Ties	1	
15	85090167	Magnet	1	
16	81400290	Filter	1	
17	81400309	Motor	1	
18	81400348	AC connector	1	
19	10420148	Cup Head Bolt	2	
20	81400481	Cover of Motor Terminal Box	1	
21	10420070	Switch	1	
22	81400560	Throttle valve	1	
23	81400266	Relief valve	1	
24	81400284	Iron plug	1	
25	81400452	Hair pin	1	
26	81400451	Handle For Release Valve	1	
27	10209020	Plastic ball	1	
28	81400421	Nut for release valve	1	
29	81400422	Self locking Flat pad	1	
30	81400447	Valve seat(low)	1	
31	81400567	Release valve	1	
32	81400560	Check valve	1	
33	81400367	Oil return pipe	1	
34	81400364	Hose clamp	1	
35	81400263	Filler cap	1	
36	81400319	Reservoir	1	

4.4 Illustration of hydraulic valve for hydraulic power unit

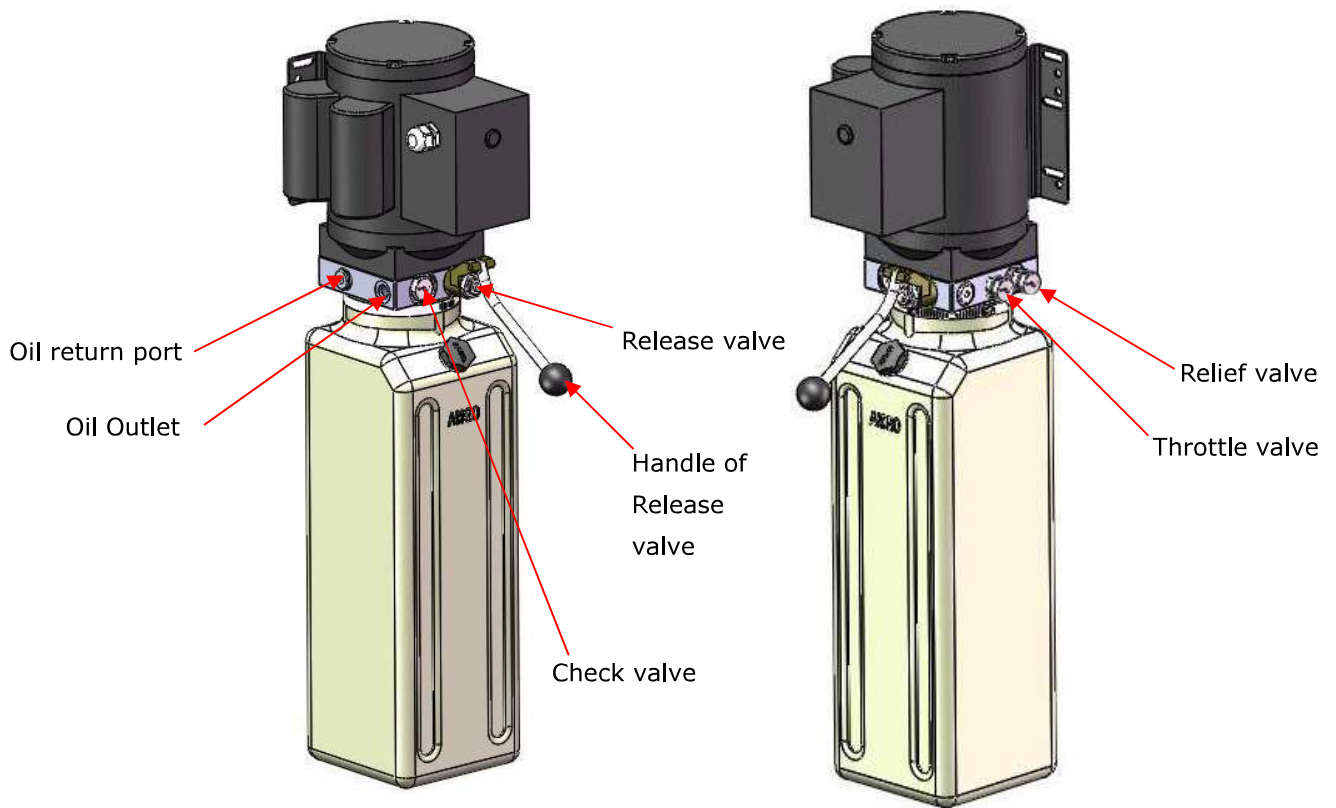

Fig.46

V. TEST RUN

1. Adjust synchronous cable (See Fig. 47)

Use Spanner to hold the cable fitting, meanwhile use ratchet spanner to tighten the cable nut. Make sure two cables are with the same tension so that two carriages can work synchronously.

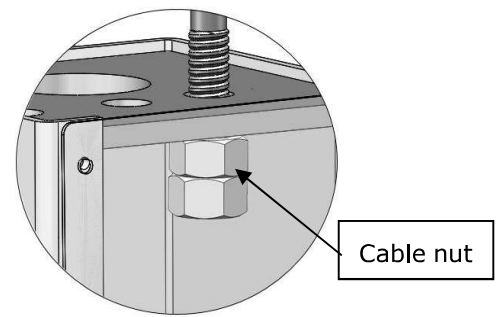

Fig. 47

If the carriage does not Synchronize when lifting , please tighten the cable nut.

2. Adjust safety cable

Lifting the carriages and lock at the same height, strain the safety cable and then release a little, and then tighten the cable nuts. Make sure the safety device can always be worked properly.

3. Exhaust air

This hydraulic system is designed to bleeding air by loosening the bleeding plug. Lifting the carriages to about 1 meter height, and loose the bleeding plug, the air would be bled automatically, then tighten the plug after bleeding, the lift would work stably and smoothly, otherwise repeat bleeding (**See Fig. 48**).

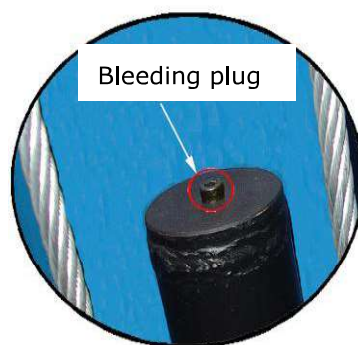

Fig. 48

4. Adjust the lower speed

You can adjust the lower speed of the lift if needing: then turn the throttle valve clockwise to decrease the lower speed, or counterclockwise to increase the lower speed.

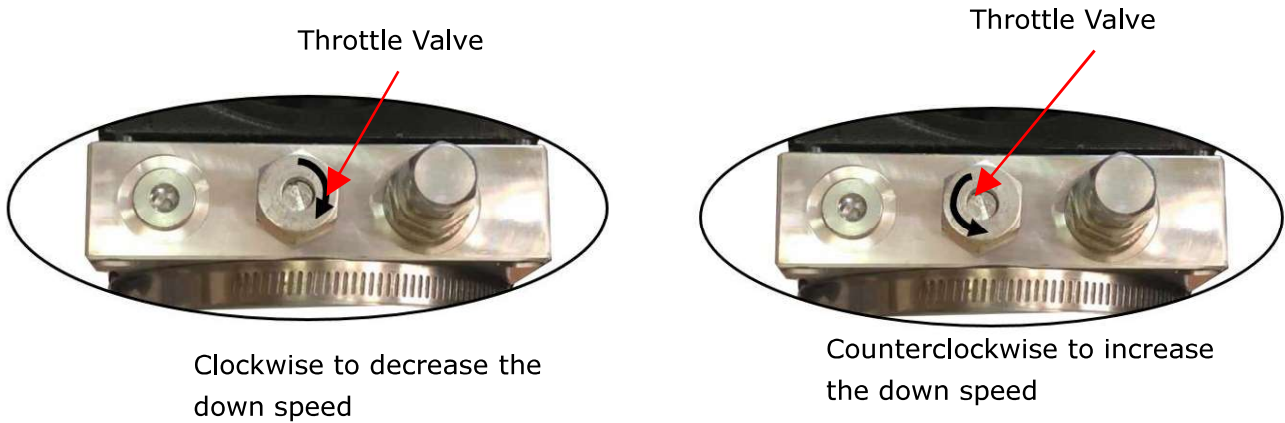

Fig. 49

5. Test with load

After finishing the above adjustment, test running the lift with load. Run the lift in low position for several times first, make sure the lift can rise and lower synchronously, the safety device can lock and release synchronously. And then test run the lift to the top completely. If there are anything improper, repeat the above adjustment.

NOTE: It may be vibrated when lifting at start, lifting it with load for several times, the air would be bled and the vibration would be disappeared automatically.

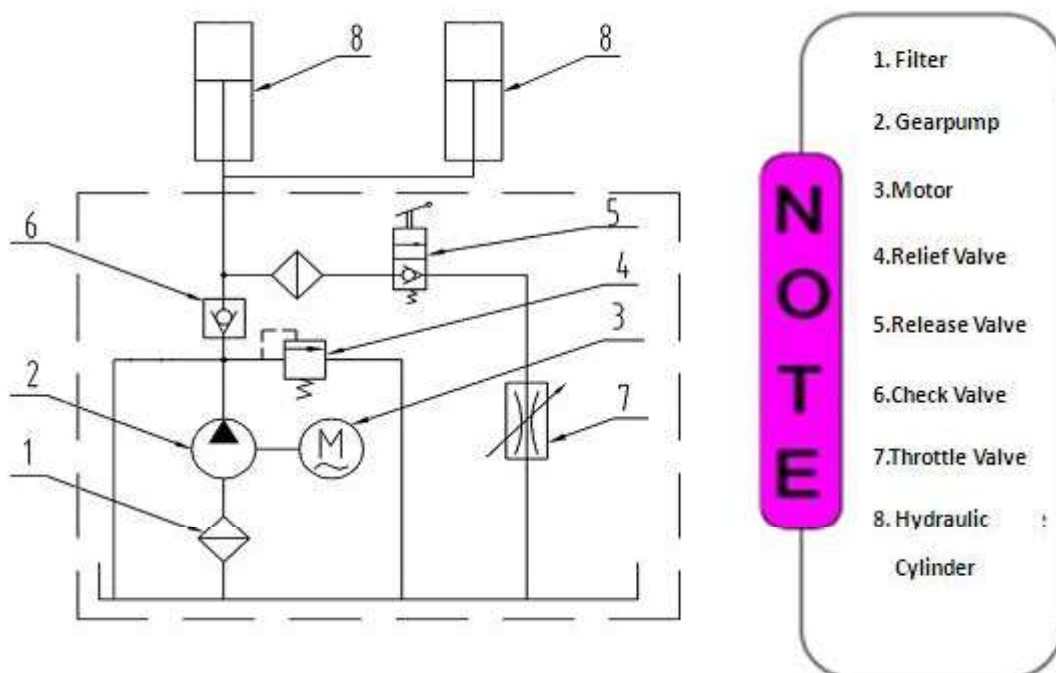

Fig. 50
Hydraulic Schematic Diagram

VI. OPERATION INSTRUCTIONS

Please read the safety tips carefully before operating the lift

To lift vehicle

1. Keep clear of site near the lift;
2. Position lift arms to the lowest position;
3. To shortest lift arms;
4. Open lift arms;
5. Position vehicle between columns;
6. Move arms to the vehicle's lifting point;

Note: The four lift arms must at the same time contact the vehicle's lifting point where manufacturers recommended

7. Push button "**UP**" until the lift pads contact underside of vehicle totally. Recheck to make sure vehicle is secure;
8. Continue to raise the lift slowly to the desired working height, ensuring the balance of vehicle;
9. Push lowering handle to lower lift onto the nearest safety. The vehicle is ready to repair.

To lower vehicle

1. Be sure clear of around and under the lift, only leaving operator in lift area;
2. Push button "**UP**" to raise the vehicle slightly, and then release the safety device, lower vehicle by pushing lowering handle.
3. Open the arms and position them to the shortest length;
4. Drive away the vehicle.
5. Turn off the power.

Note: In order to extend the life of cylinder and seal, please raised the lift as least once each day.

VII. MAINTENANCE SCHEDULE

Monthly:

1. Re-torque the anchor bolts to 150 Nm;
2. Check all connectors, bolts and pins to insure proper mounting;
3. Lubricate cable with lubricant;
4. Make a visual inspection of all hydraulic hoses/lines for possible wear or leakage;
5. Check safety device and make sure proper condition;
6. Lubricate all rollers and pins with 90wt. Gear oil or equivalent;

Note: All anchor bolts should take full torque. If any of the bolts does not function for any reason, DO NOT use the lift until the bolt has been replaced.

Every six months:

1. Make a visual inspection of all moving parts for possible wear, interference or damage.
2. Check and adjust as necessary, equalizer tension of the cables to insure level lifting.
3. Check columns for plumbness.
4. Check rubber pads and replace as necessary.
5. Check safety device and make sure proper condition.

VIII. TROUBLE SHOOTING

TROUBLE	CAUSE	REMEDY
Motor does not run	<ol style="list-style-type: none"> 1. Start Button does not work 2. Wiring connections are not in good condition 3. Motor burned out 4. AC contactor burned out 5. Height limit switch is damaged 	<ol style="list-style-type: none"> 1. Replace start button 2. Repair all wiring connections 3. Repair or replace motor 4. Replace AC contactor 5. Repair or Replace
Motor runs but the lift is not raised	<ol style="list-style-type: none"> 1. Motor runs in reverse rotation 2. Gear pump out of operation 3. Release valve in damage 4. Relief valve or check valve in damage 5. Low oil level 	<ol style="list-style-type: none"> 1. Reverse two power wire 2. Repair or replace 3. Repair or replace 4. Repair or replace 5. Fill tank
Lift does not stay up	<ol style="list-style-type: none"> 1. Release valve out of work 2. Relief valve or check valve leakage 3. Cylinder or fittings leaks 	Repair or replace
Lift raises slowly	<ol style="list-style-type: none"> 1. Oil line is jammed 2. Motor running on low voltage 3. Oil mixed with air 4. Gear pump leaks 5. Overload lifting 	<ol style="list-style-type: none"> 1. Clean the oil line 2. Check electrical system 3. Fill tank 4. Replace pump 5. Check load
Lift cannot lower	<ol style="list-style-type: none"> 1. Safety device are in activated 2. Release valve in damage 3. Safety cable broken 4. Oil system is jammed 	<ol style="list-style-type: none"> 1. Release the safeties 2. Repair or replace 3. Replace 4. Clean the oil system

IX. LIFT DISPOSAL:

When the car lift cannot meet the requirements for normal use and needs to be disposed, it should follow local laws and regulations.

CLASSIC LIFT

