

CLASSIC LIFT

Original

Installation And Service Manual

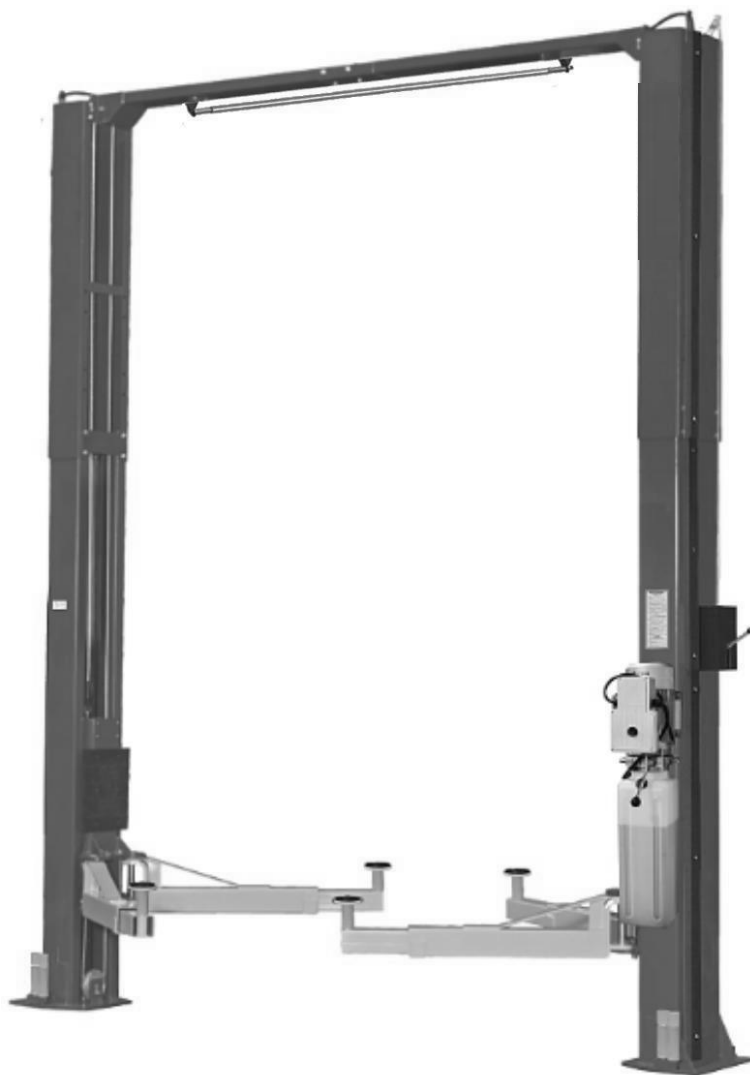

TWO-POST LIFT
MODEL: CL6800C

CONTENTS

Product Features and Specifications	1
Installation Requirement	3
Steps of Installation	5
Exploded View	25
Test Run	34
Operation Instruction	36
Maintenance	37
Trouble Shooting	38
Scarping of equipment.....	38

I. PRODUCT FEATURES AND SPECIFICATIONS

CLEAR-FLOOR DIRECT-DRIVED MODEL FEATURES

Model CL6800C (See Fig. 1)

- Direct-driven design, minimize the lift wear parts and breakdown ratio
- Dual hydraulic cylinders are designed and manufactured according to high standard, utilizing imported seals
- Self- lubricating UHMW Polyethylene sliders and bronze bush
- Single-point safety release with dual safety design
- Clear-floor design, provide unobstructed floor use
- Overhead safety shut-off device prevents vehicle damage
- Standard adjustable heights accommodate varying ceiling heights

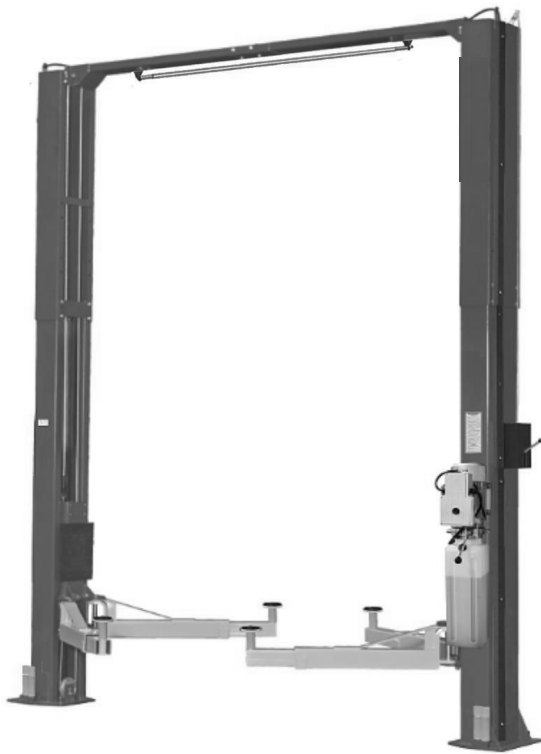

Fig. 1

MODEL CL6800C SPECIFICATION

Model	Style	Lifting Capacity	Lifting Time	Lifting Height	Overall Height	Overall Width	Minimum Pad Height	Motor
CL6800C	Clear-floor Direct-driven	15,000lbs (6800kg)	90s	1912~2141mm	174"/198" (4420/5029mm)	150 3/4" (3829mm)	7 1/4" -16 1/4" (185-414mm)	4.0HP

Arm Swings View

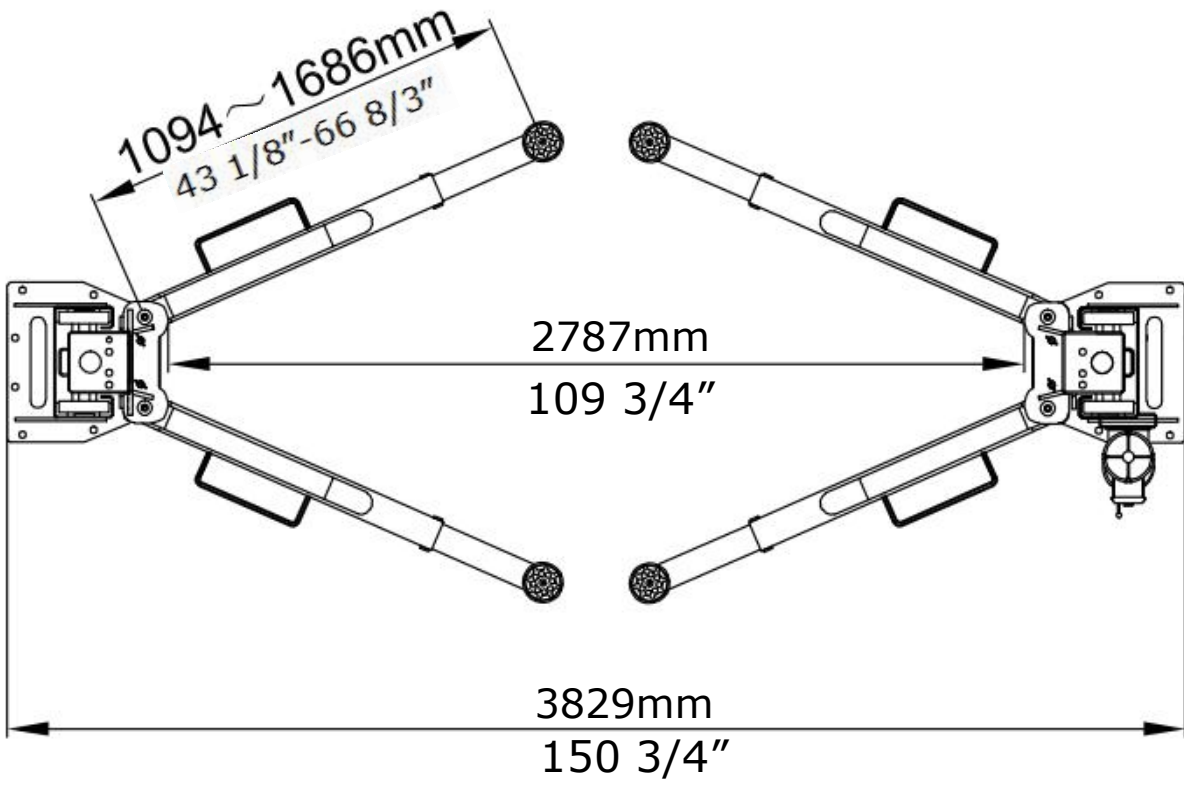

Fig. 2

II. INSTALLATION REQUIREMENT

A. TOOLS REQUIRED

↳ Rotary Hammer Drill ($\Phi 19$)



↳ Hammer



↳ Level Bar



↳ English Spanner (12")



↳ Wrench set: (10#, 13#, 14#, 15#, 17#, 19#, 24#, 27#, 30#)



↳ Ratchet Spanner With Socket (28#)



↳ Carpenter's Chalk



↳ Screw Sets



↳ Tape Measure (7.5m)



↳ Pliers



↳ Lock Wrench



↳ Socket Head Wrench (3#, 5#, 8#)



Fig.3

B. Equipment storage and installation requirements.

The equipment should be stored or installed in a shady, normal temperature, ventilated and dry place.

C. The equipment should be unload and transfer by forklift.



Fig.4

D. SPECIFICATIONS OF CONCRETE (See Fig. 5)

Specifications of concrete must be adhered to the specification as following.

Failure to do so may result in lift and/or vehicle falling.

1. Concrete must be thickness 5"(120mm) minimum and without reinforcing steel bars, and must be totally dry before lift installation.
2. Concrete must be in good condition and must be of test strength 3,500psi (245kg/cm²) minimum.
3. Floors must be level with no cracks or holes.

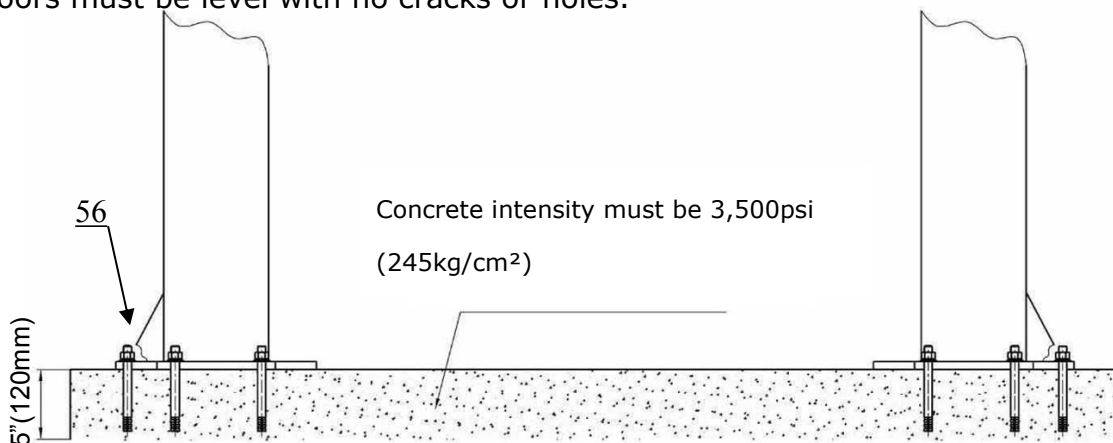

Fig. 5

E. POWER SUPPLY

The electrical source must be 3KW minimum. The source cable size must be 2.5mm² and in good condition of contacting with floor.

III. INSTALLATION STEPS

A. Location of installation

Check and ensure the installation location (concrete, layout, space size etc.) is suitable for lift installation.

B. Use a carpenter's chalk line to establish installation layout of baseplate (See Fig. 6)

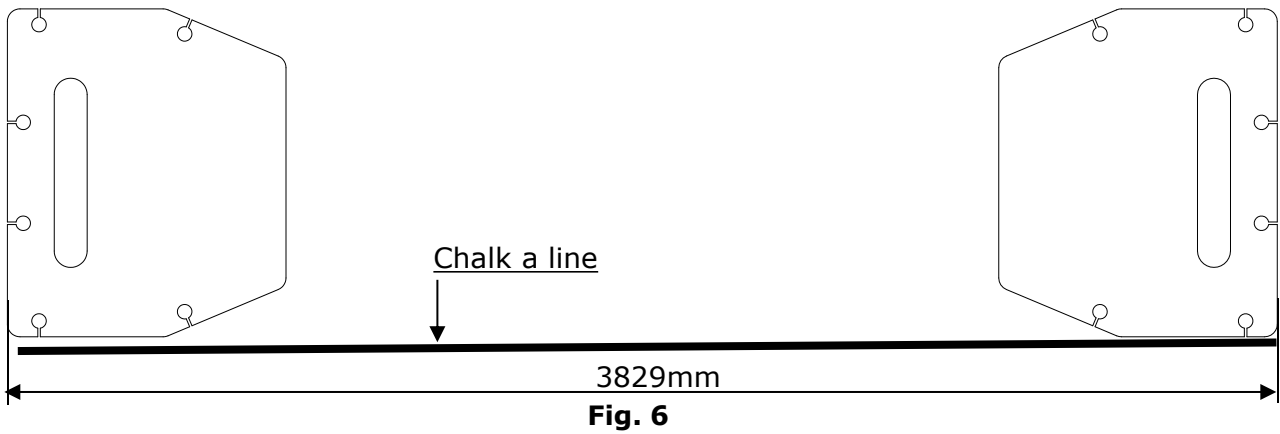

C. Check the parts before assembly.

1. Packaged lift, hydraulic power unit and parts box; (**Remark: Outer column is packed into the machine**) (See Fig. 7).



2. Move the lift aside with a fork lift or hoist, and open the outer packing carefully (See Fig. 8).

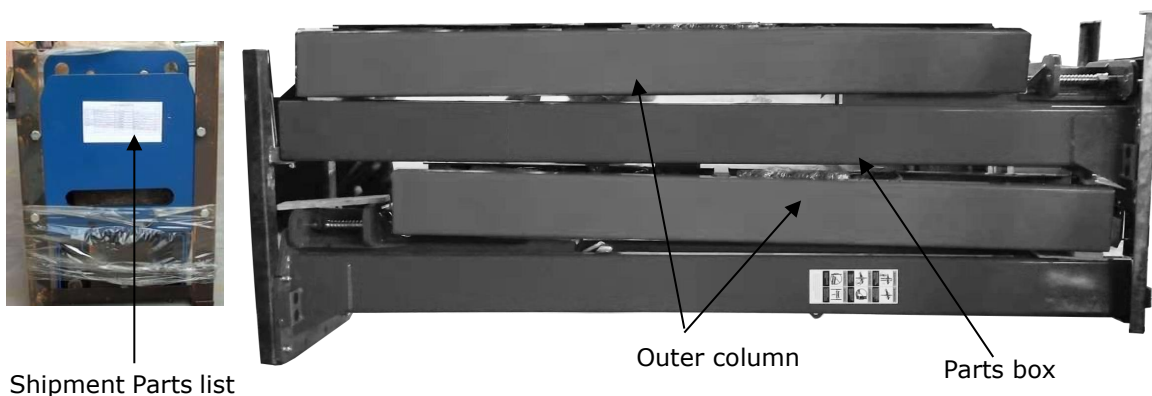

3. Take out 2pcs outer column, then place the inner column to the installation location . **(See Fig. 9).**



Fig. 9

4. Lift the upper column with a fork lift or hoist, loosen the bolts of the upper package stand, take out the parts in the inner column **(See Fig. 10).**



Fig. 10

5. Lift the lower column with a fork lift or hoist, take down the package stand, than take off the lower outer column, take out the parts in the inner column **(See Fig. 11).**

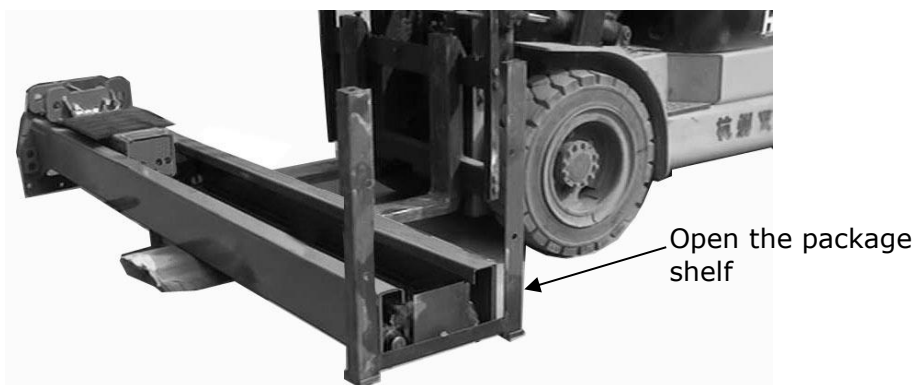
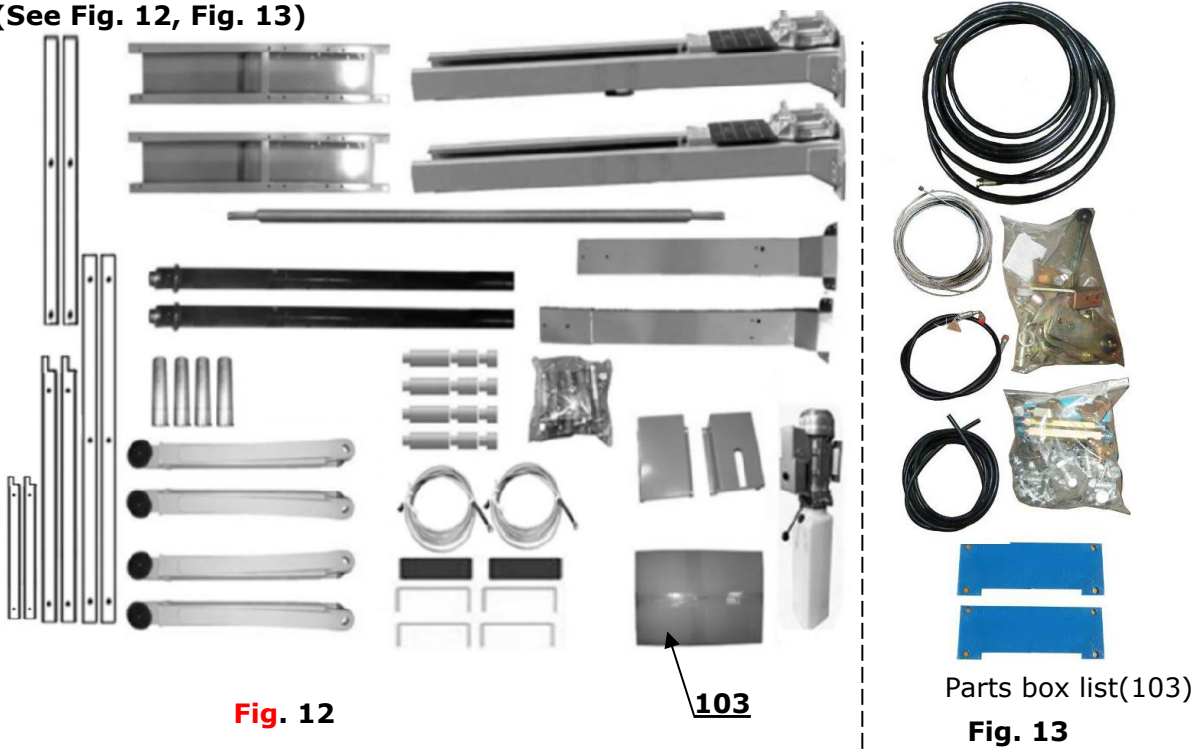
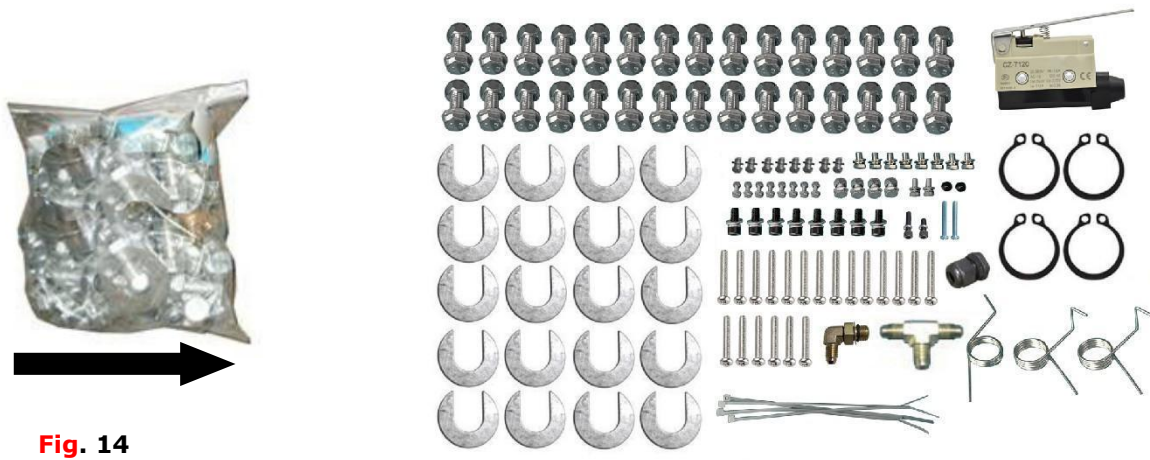

Fig. 11

6. Move aside the parts and check the parts according to the shipment parts list
 (See Fig. 12, Fig. 13)



7. check the parts of the parts bag 1 according to parts bag list (See Fig. 14).



8. Check the parts of the parts bag 2 according to parts bag list (See Fig. 15).

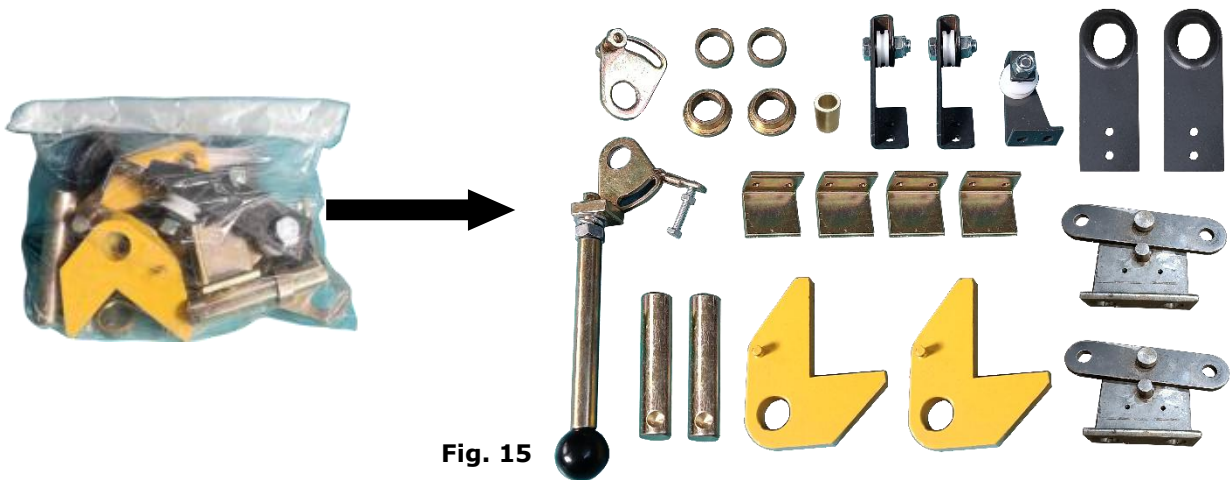

D. Install parts of extension columns (See Fig. 16).

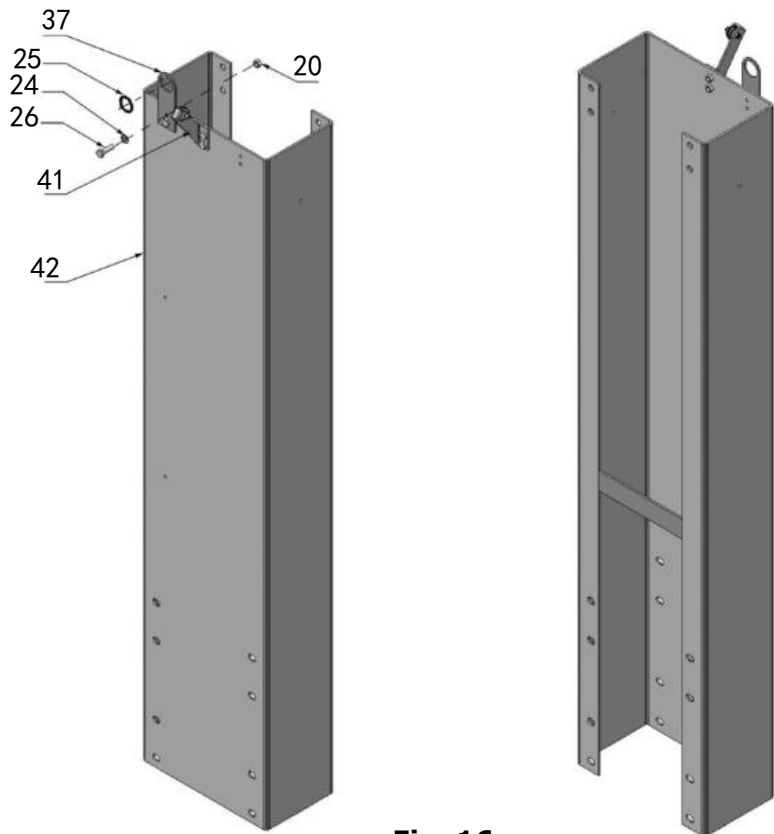

Fig. 16

E. Confirm the installation location and install hydraulic cylinder

Lay down two columns on the installation site parallelly, position the power-side column according to the actual installation site. Usually, it is suggested to install power-side column on the right side of vehicle driven-in, and then put the cylinder into the carriages. (See Fig. 17).

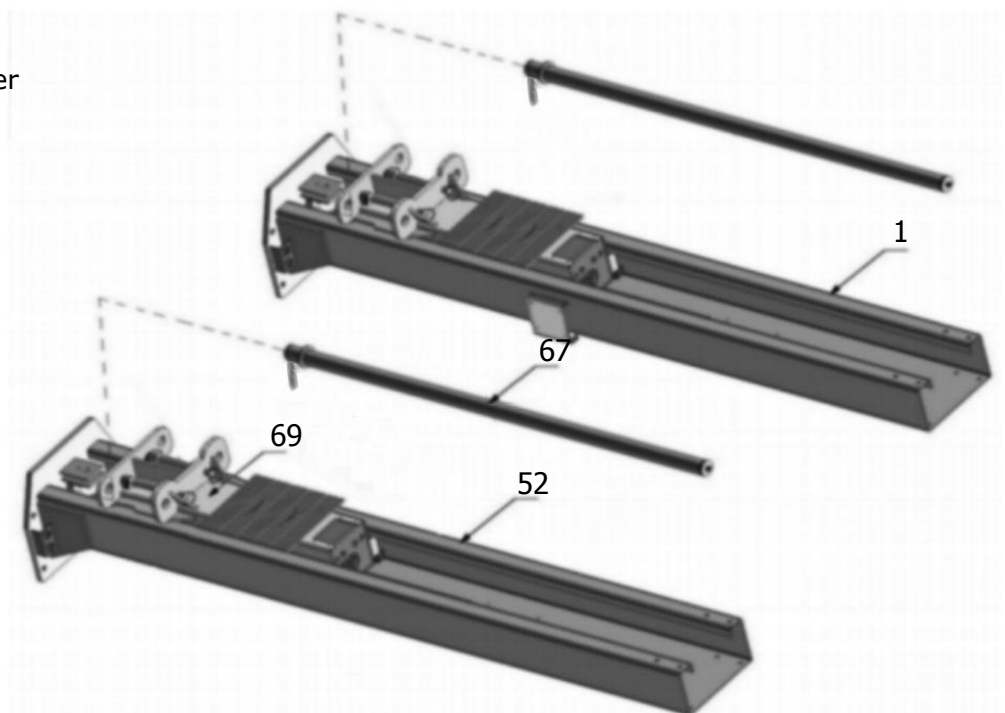
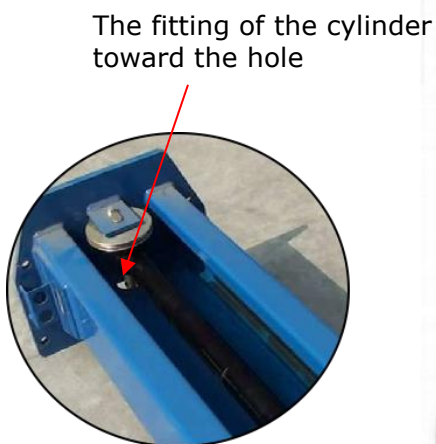

Fig. 17

F. Install columns

This lift is designed with 2-Section columns. Adjustable height according to the ceiling height and connecting the inner and outer columns.

If the ceiling height is over 5035mm, it can be installed in a high setting; if the ceiling height between 4430mm-5035mm, it can be installed in the low setting; it is not allowed to install if the ceiling height less than 4430mm.

1. High Setting, connecting the outer columns with the lower hole (**See Fig. 19**).

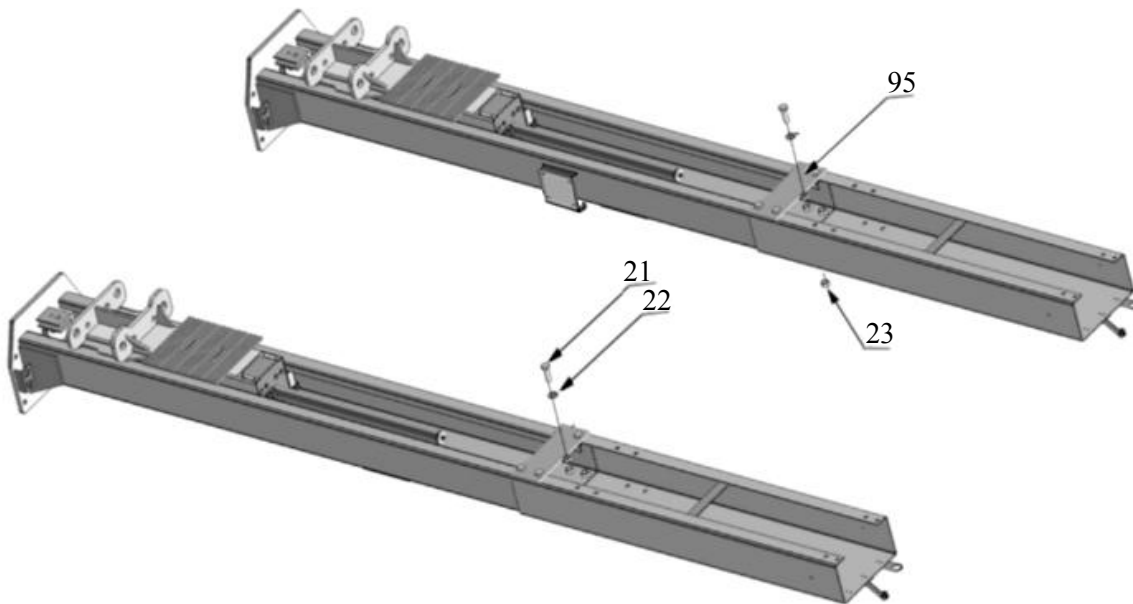

Fig. 18 High setting

2. Low Setting: connecting the extension columns with the upper hole (**See Fig.19**).

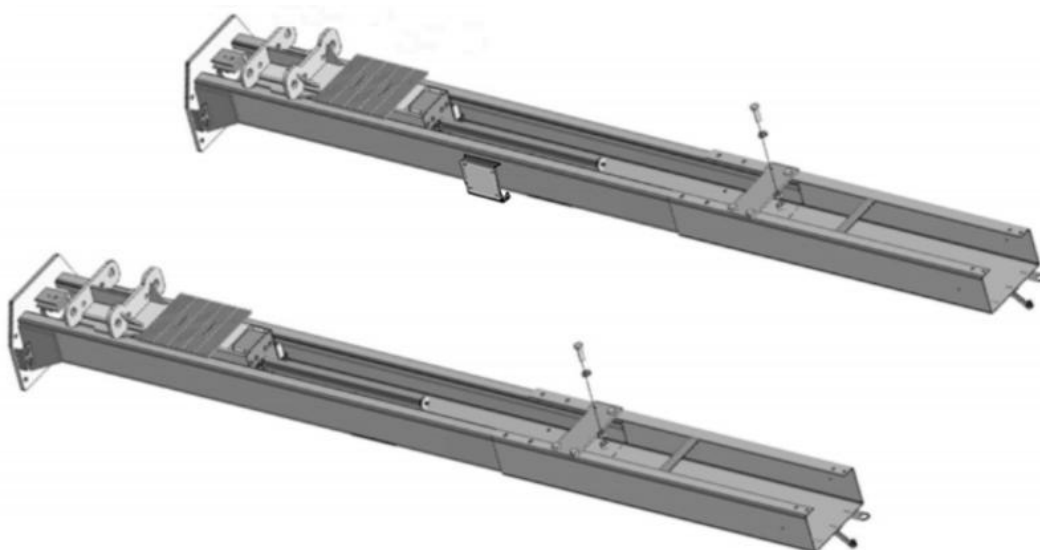
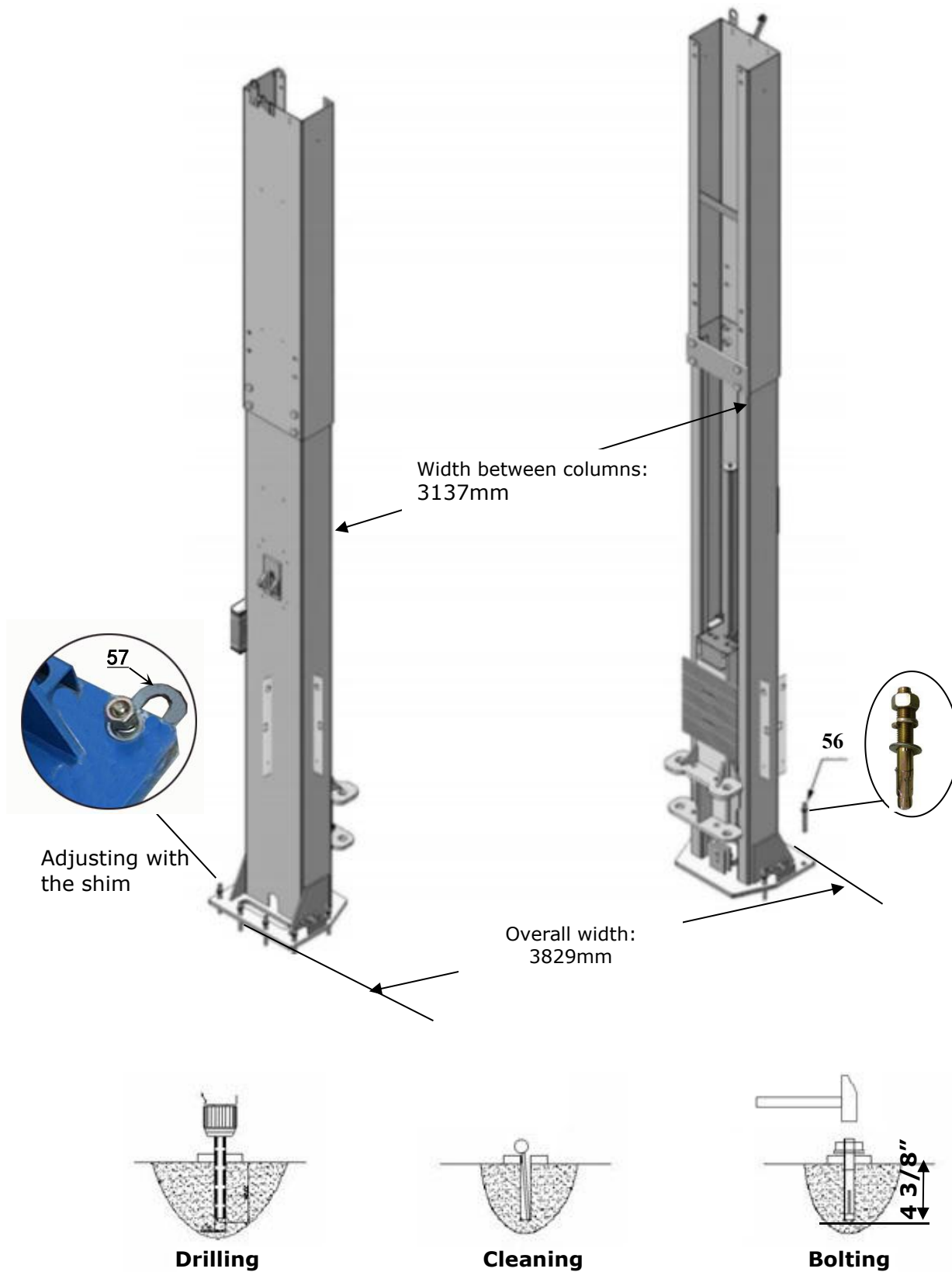

Fig. 19 Low setting

G. Install anchor bolts. Position the columns on the installation layout. Check the columns verticality with level bar, and adjusting with the shim if the columns are not vertical. Do not tighten the anchor bolts at this time. (See Fig.20)



Note: Minimum embedment of anchors is 110mm.

Fig. 20

H. Install overhead top beam

1. With help of the hook of top beam, put one side of top beam on top of the extension column and connecting the top beam to extension column by bolts, tighten the bolts. Then assemble the connecting bracket (See Fig. 21).

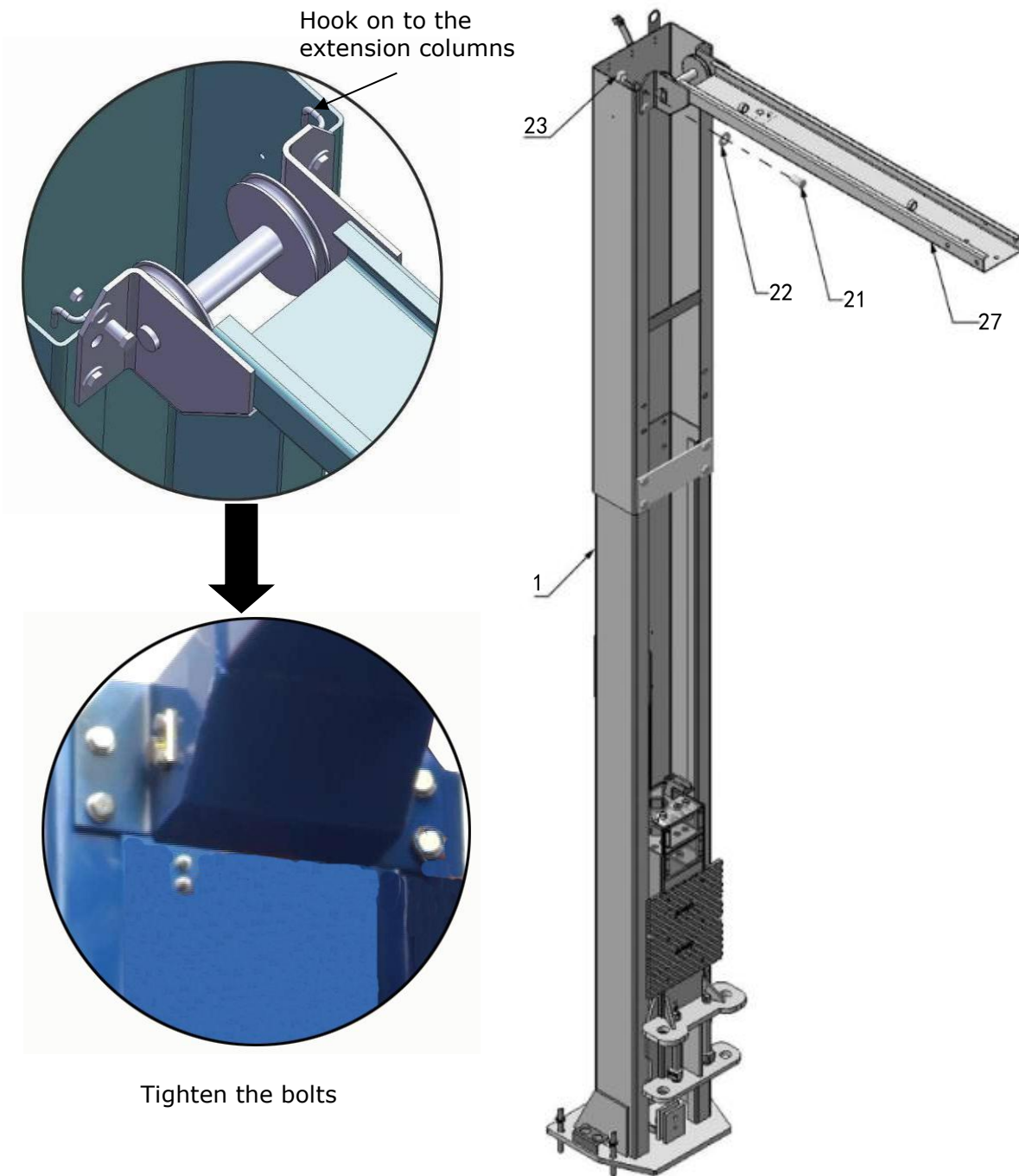
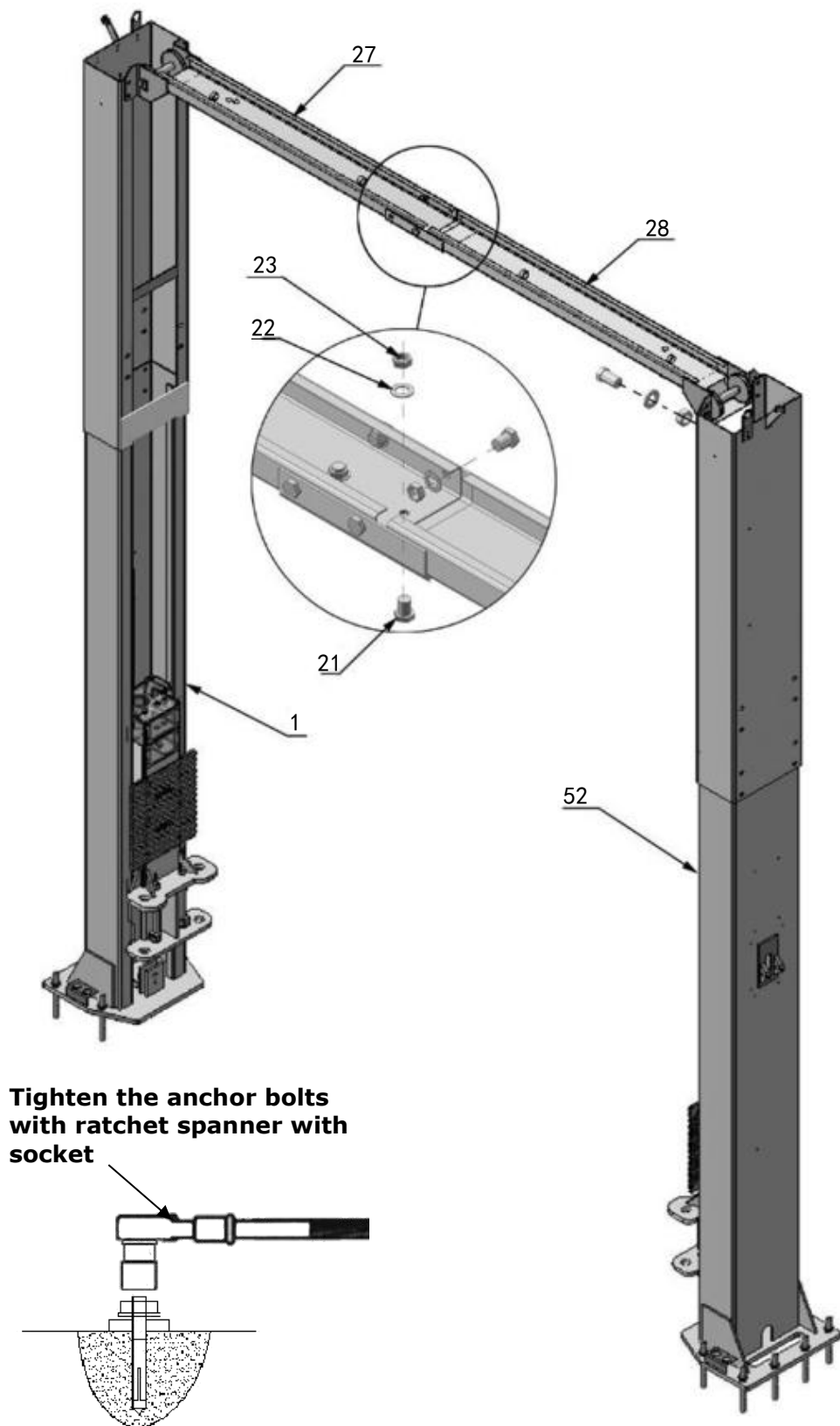
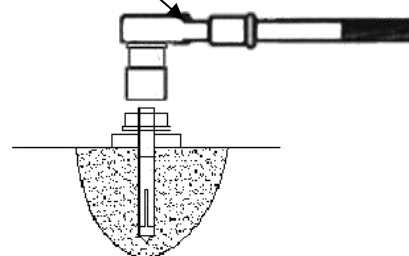

Fig. 21

2. Assemble overhead top beam, tighten the columns anchor bolts (**See Fig. 22**).



**Tighten the anchor bolts
with ratchet spanner with
socket**



Note: Torque of Anchors is
150N.m.

Fig. 22

I. Installing the limit switch control bar and limit switch (See Fig. 23、 Fig. 24).

A. Fix the control bar to the support bracket.

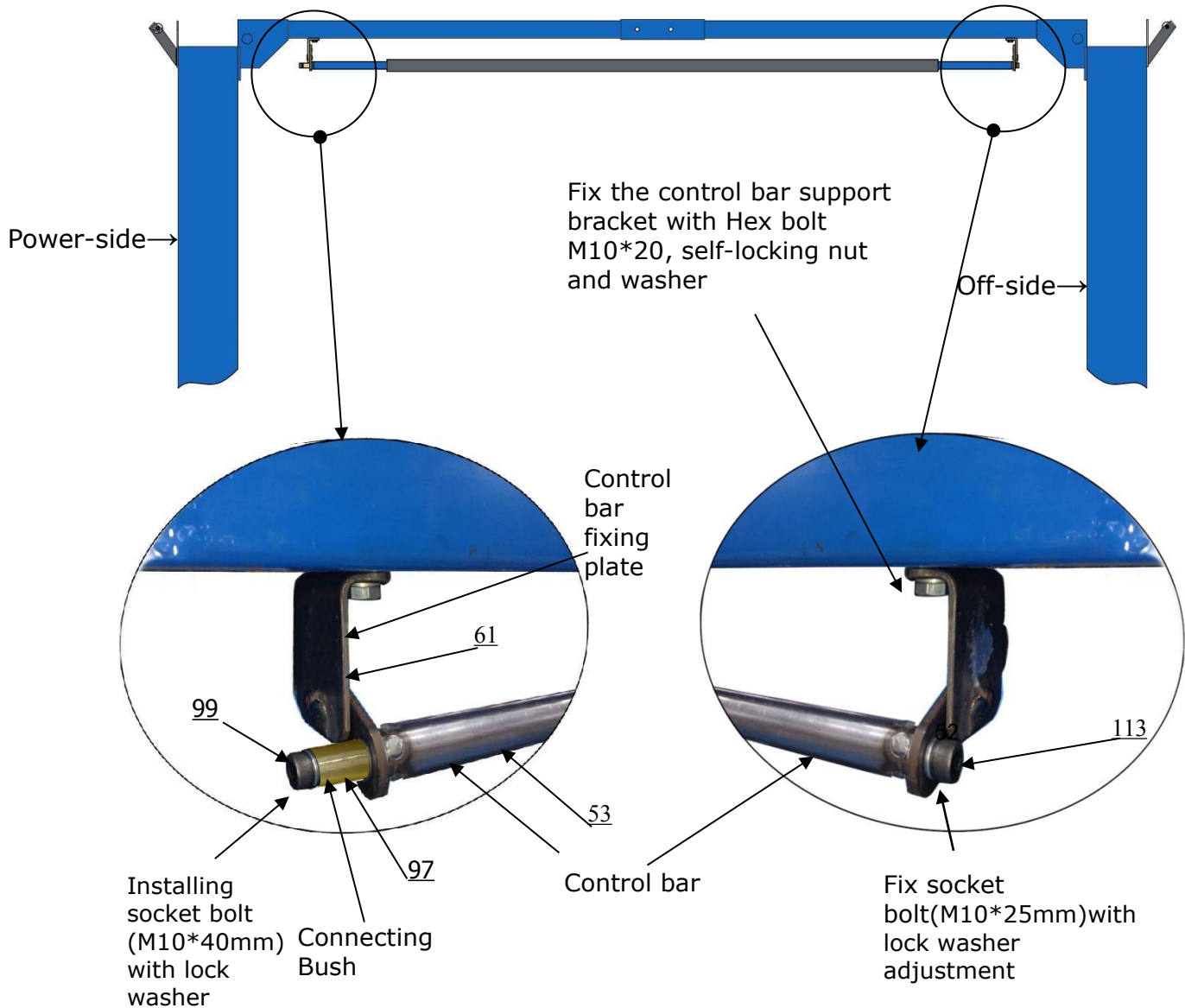

Fig. 23

B. Installing the limit switch and wire.

1. Connect the wire:

Connect the red wire to terminal NC#, another side of the wire connect to the terminal A2 on AC contactor of power unit.

Connect the black wire to terminal C#, another side of the wire connect to the terminal 4 on control button of power unit.

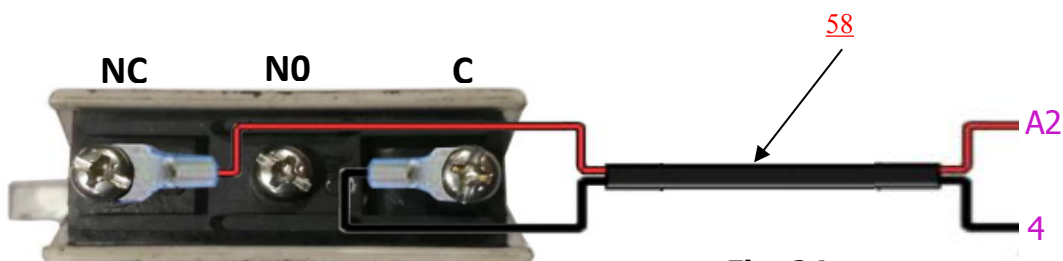
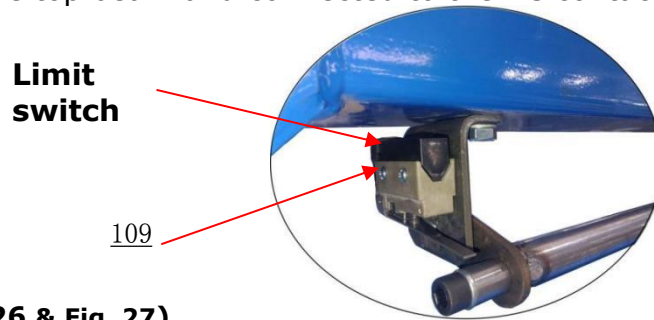

Fig. 24

2. Tighten limit switch .Fix the limit switch on control bar support bracket of the power-side as the photo. The wire pass through the top beam and connected to the AC contactor of power unit.

Fig. 25



J. Install safety device (See Fig. 26 & Fig. 27).

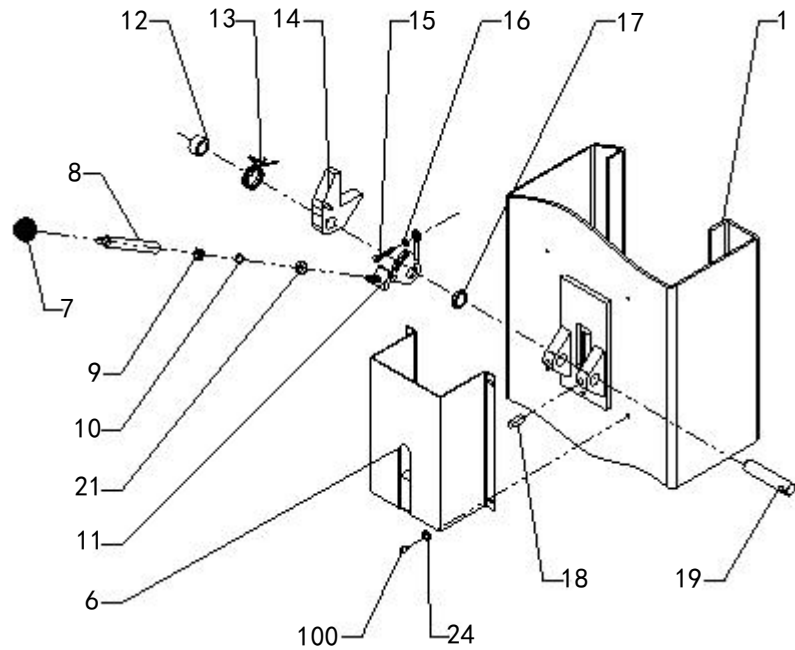
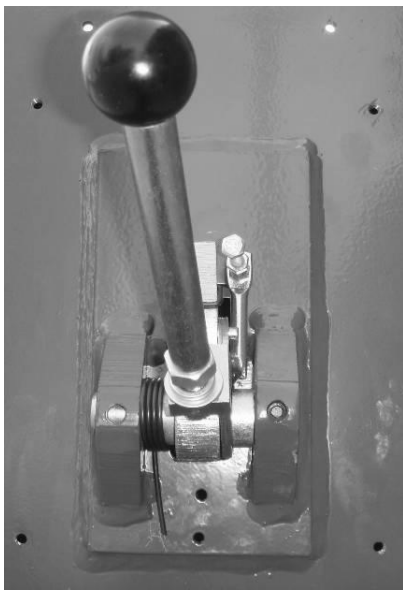

Fig. 26 Power-side safety device

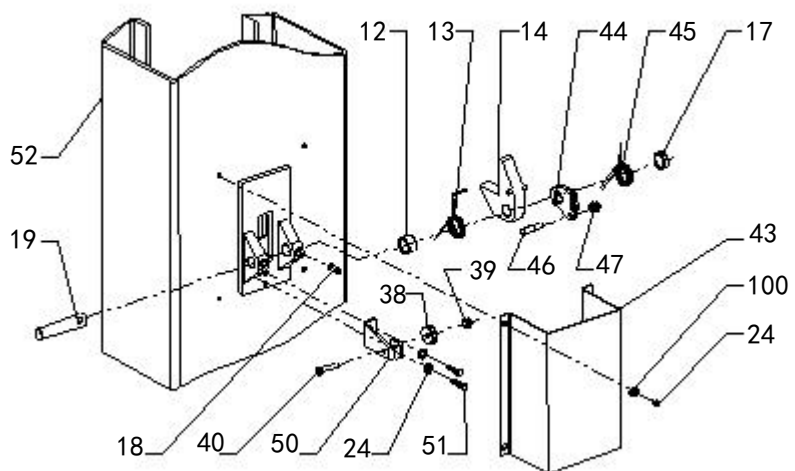
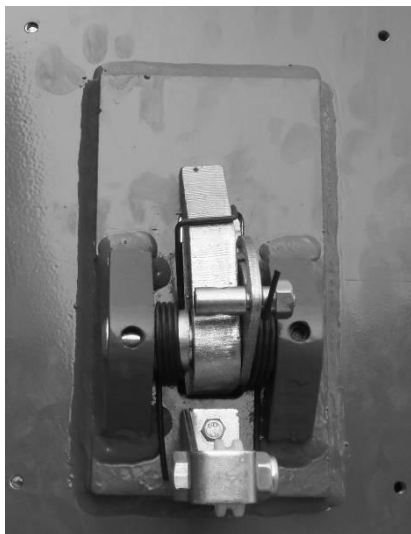

Fig. 27 Off-side safety device

K. Install cables

Raise both two carriages to the same level of lock.

1. High setting cable connection.

1.1 Take out the carriages plastic cover, cable pass through from the bottom of the carriages and be pulled out from the open of carriages, then screw the two cable nuts (**See Fig. 28**).

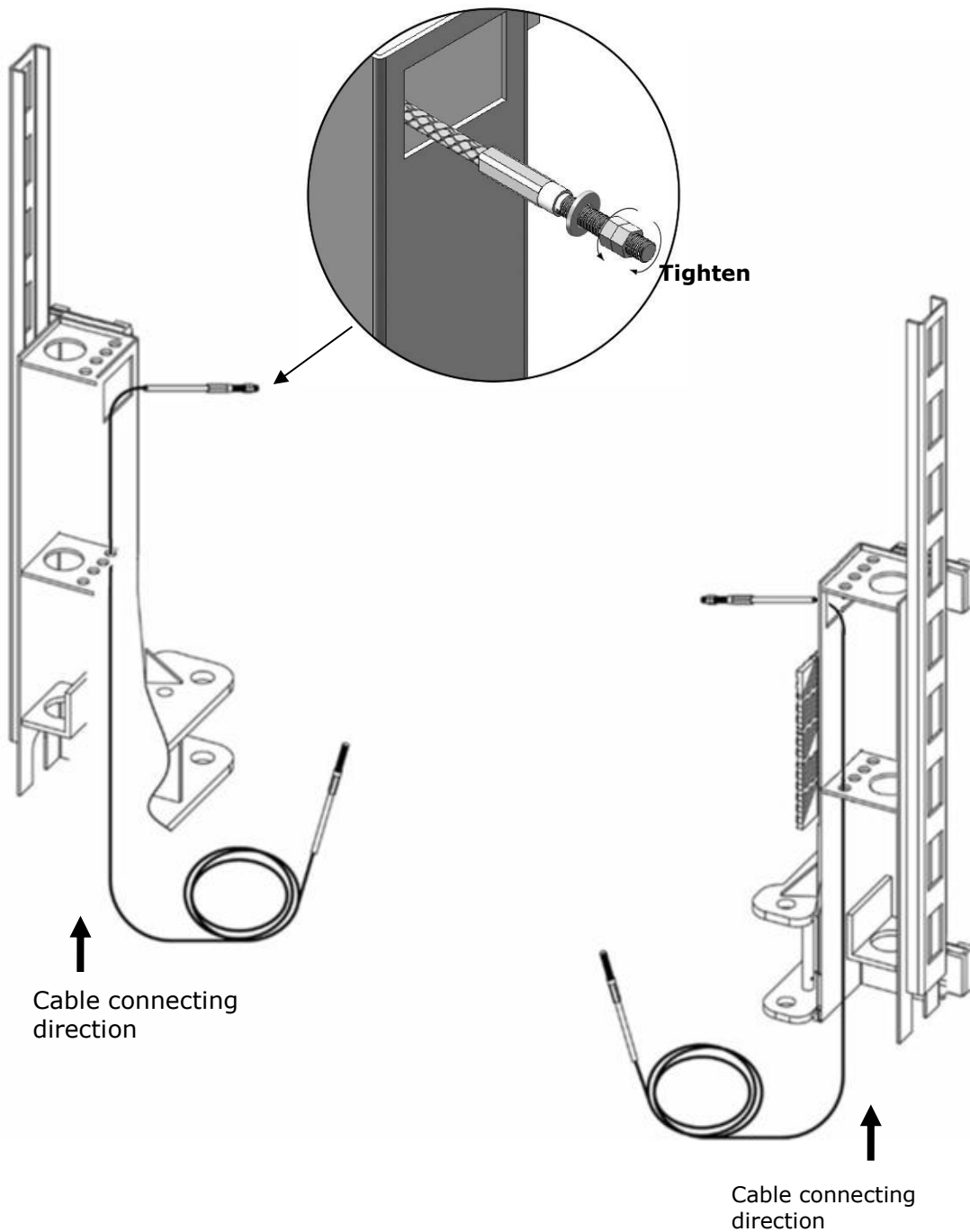

Fig. 28

1.2 Connecting cable for high setting (See Fig. 29)

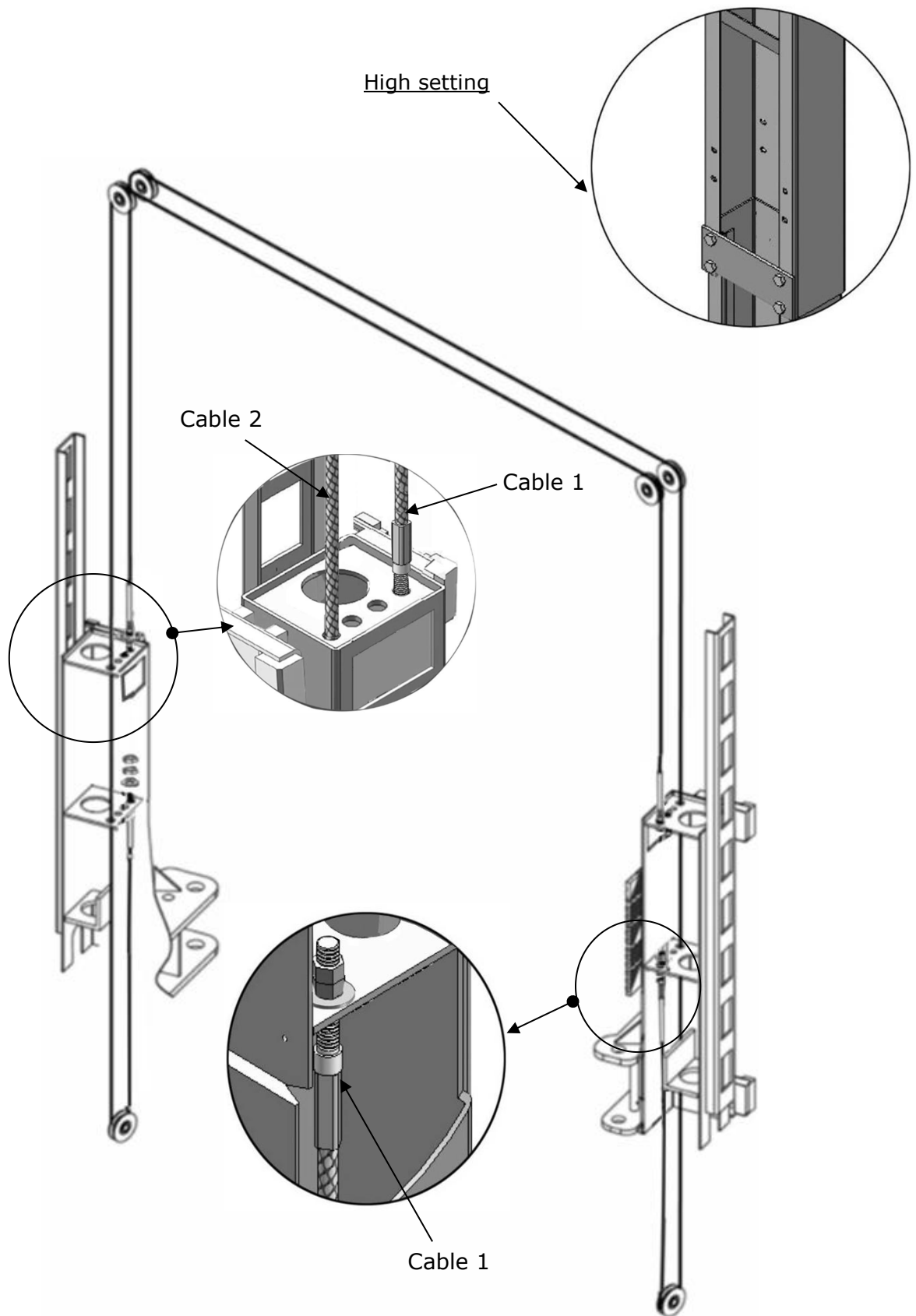

Fig. 29

2. Low setting cable connection. (See Fig. 30).

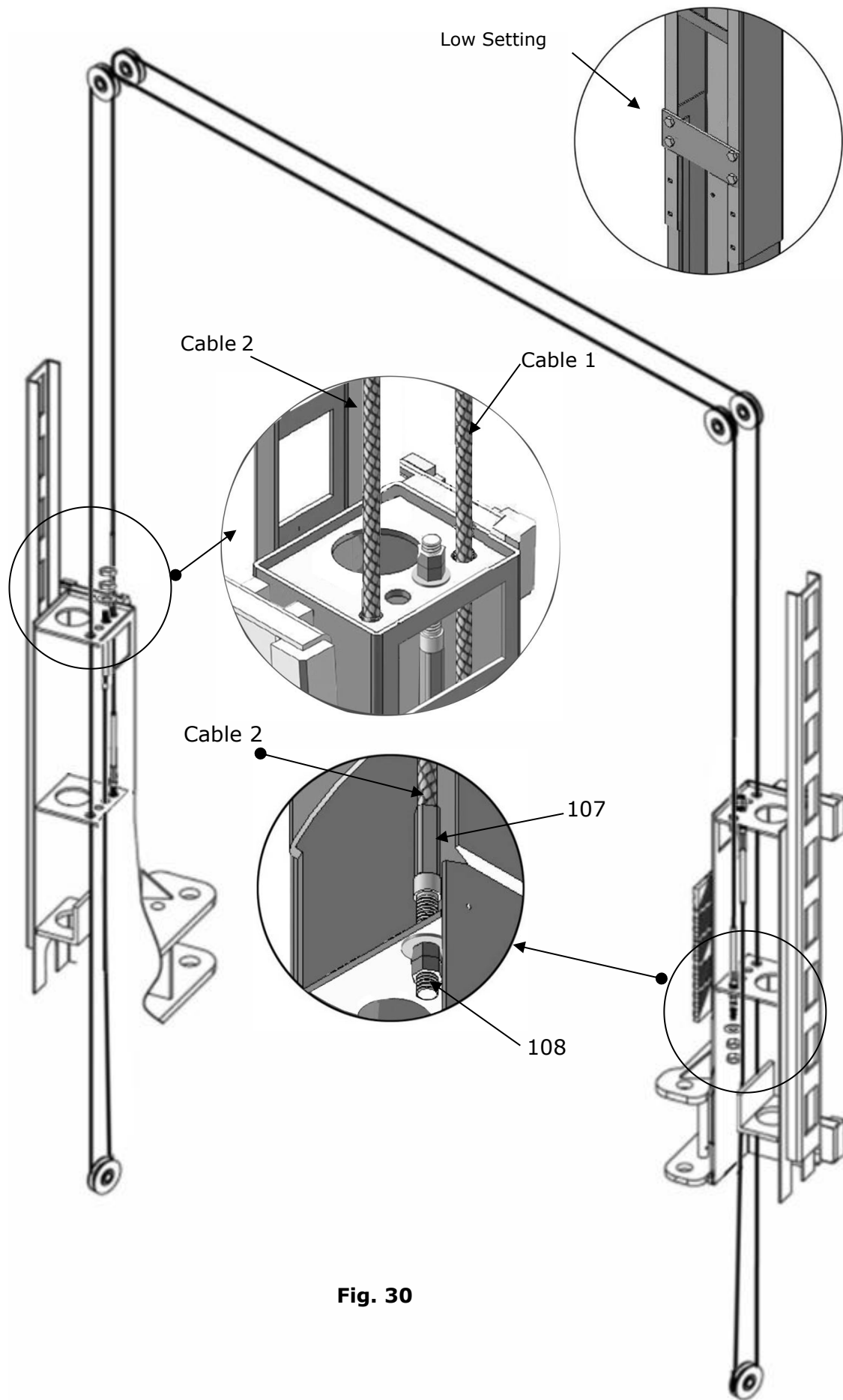

Fig. 30

L. Install power unit (See Fig. 31)

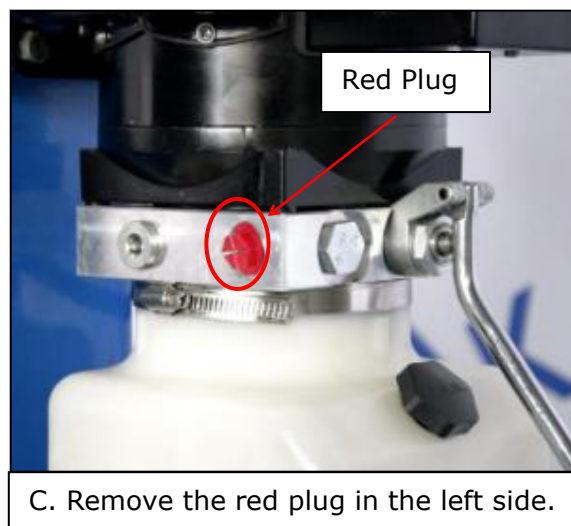
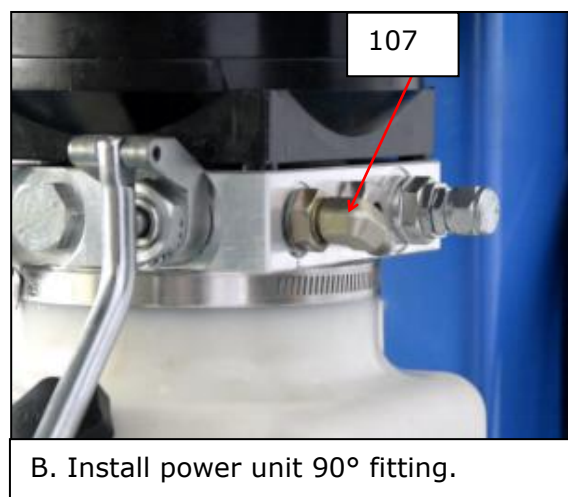
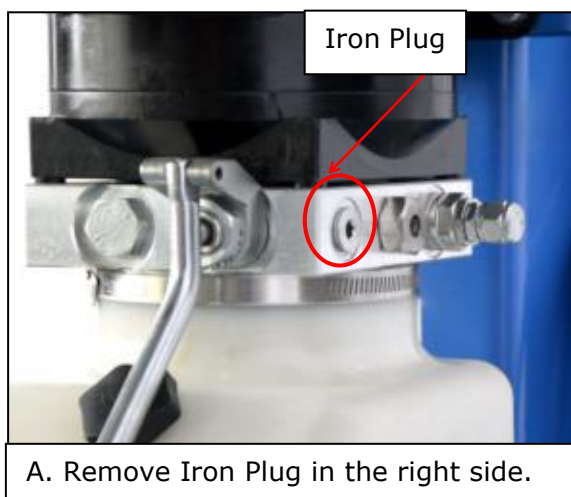
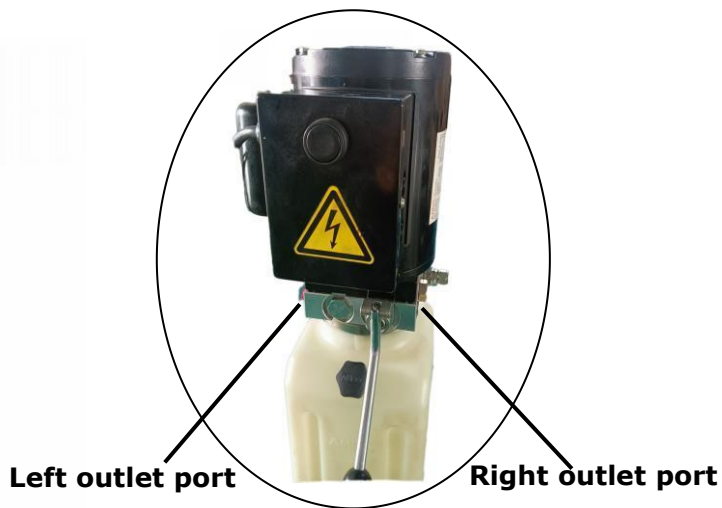
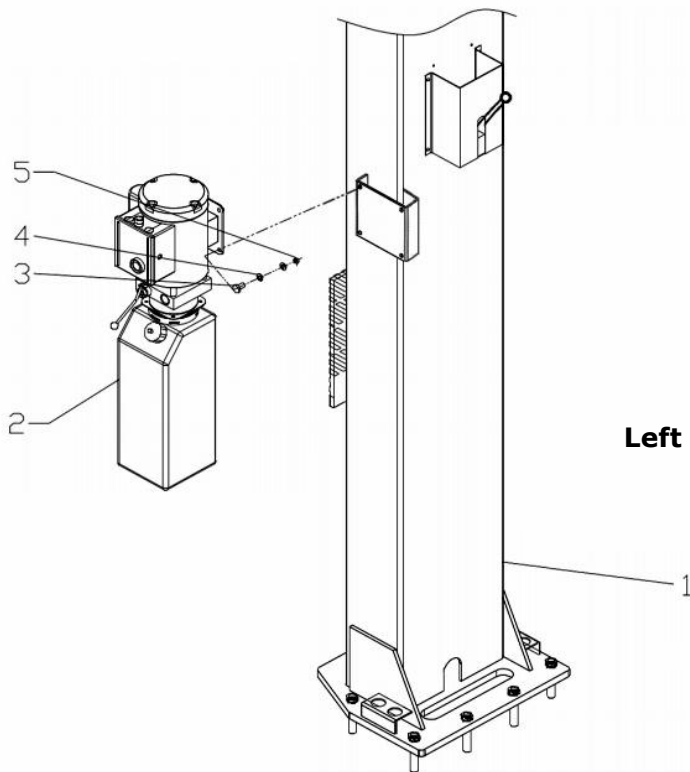
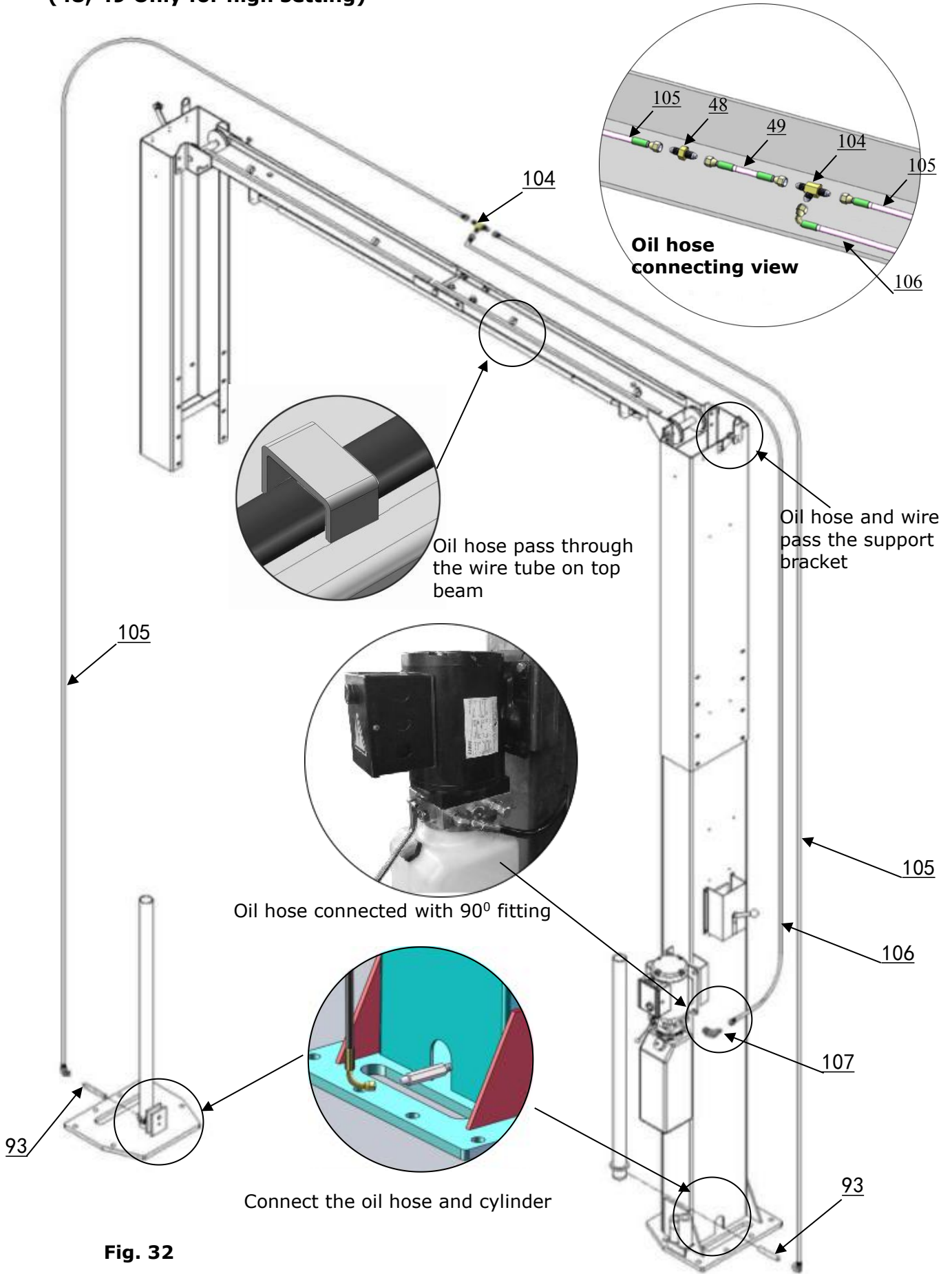

Fig. 31

M. Install oil hose (See Fig. 32)

(48, 49 Only for high setting)



N. Install safety cable. (See Fig. 33)

Install safety cable from off-side safety assy. to power-side safety assy., pass through the top beam.



Safety cable pass through small pulley bracket

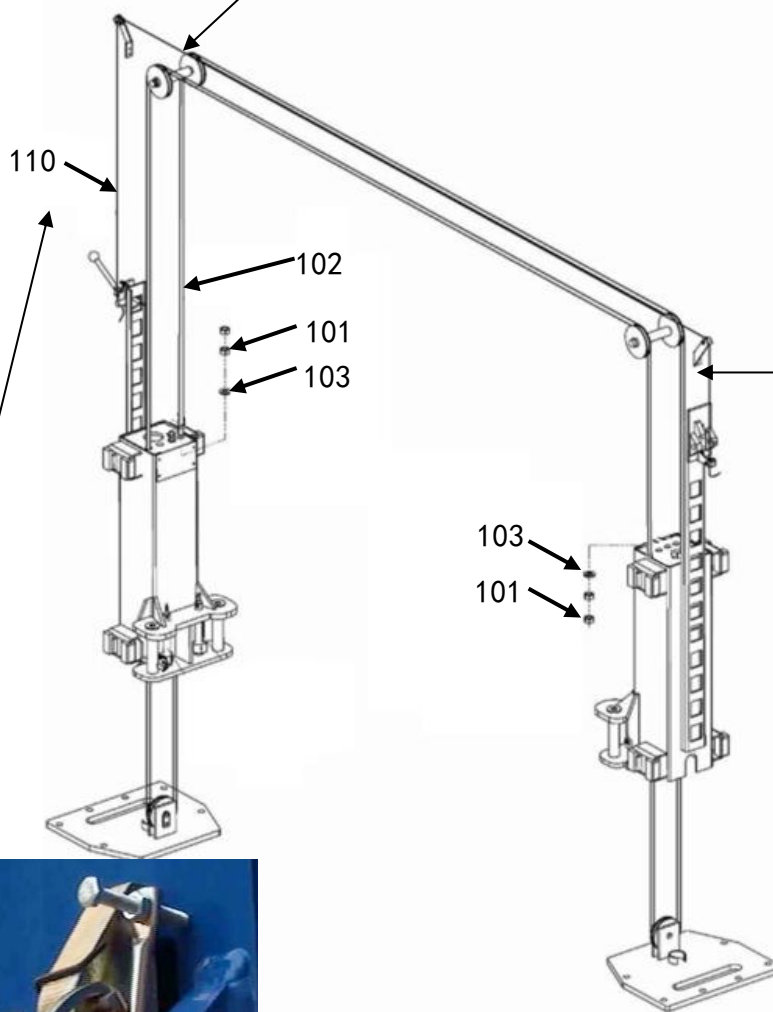

Install safety cable from off-side safety device.



Safety cable is connected with the power-side safety device.

Fig. 33

O. Install wire protective cover (See Fig. 34)

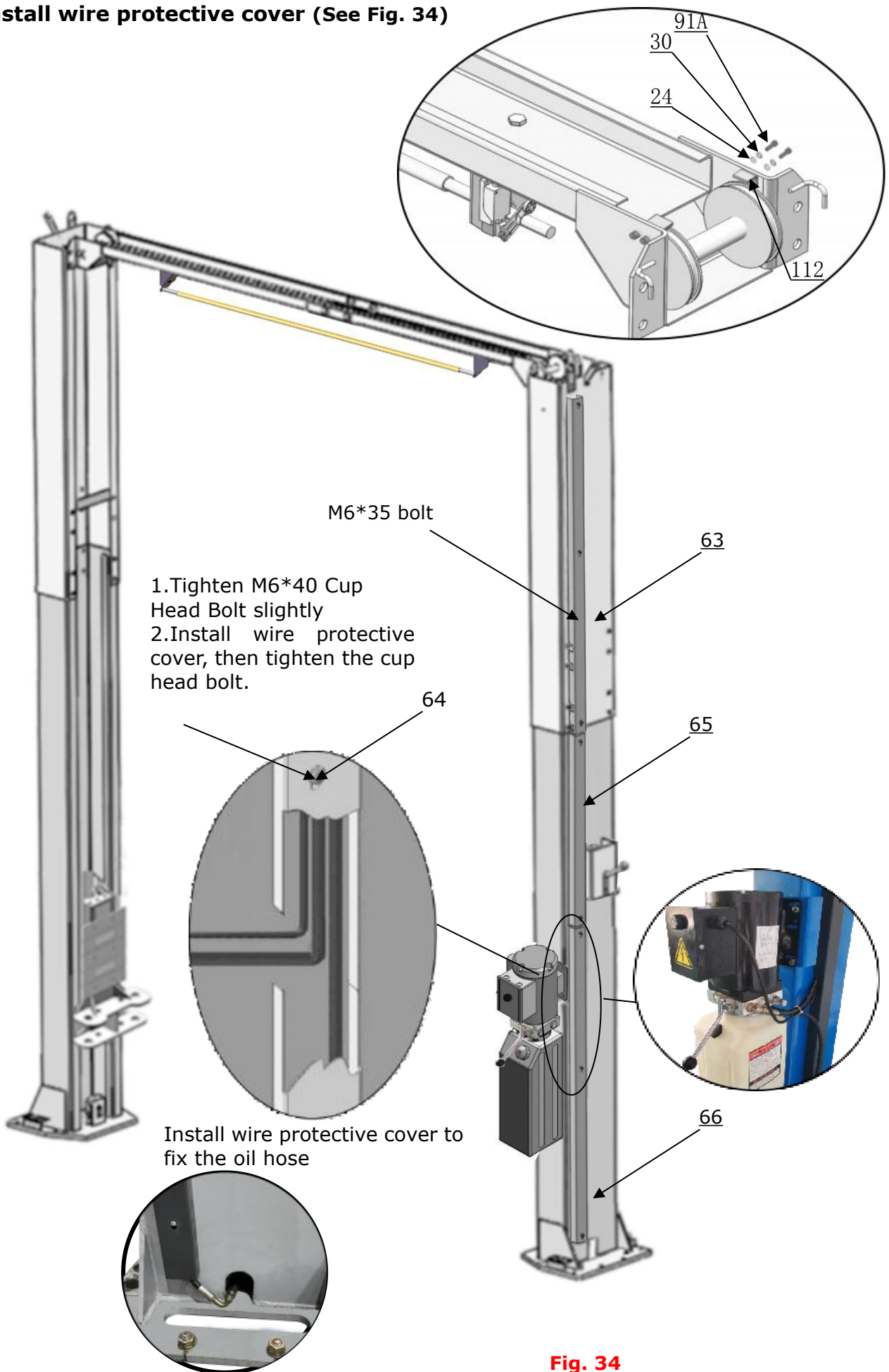

Fig. 34

P. Install lifting arms and adjust the moon gears

1. Install the lifting arms (See Fig. 35).
2. Lowering the carriages down to the lowest position, then use the 10# socket head wrench to loosen the socket bolt (See Fig. 36).
3. Adjust the arm lock as direction of arrow (See Fig. 37)
4. Adjust moon gear and arm lock to make it to be meshed, then tighten the socket bolts of arm lock (See Fig.38).

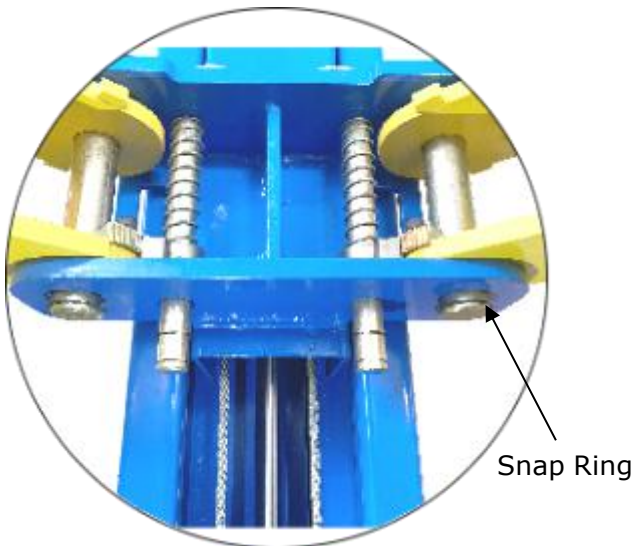

Fig. 35
Install lifting arms

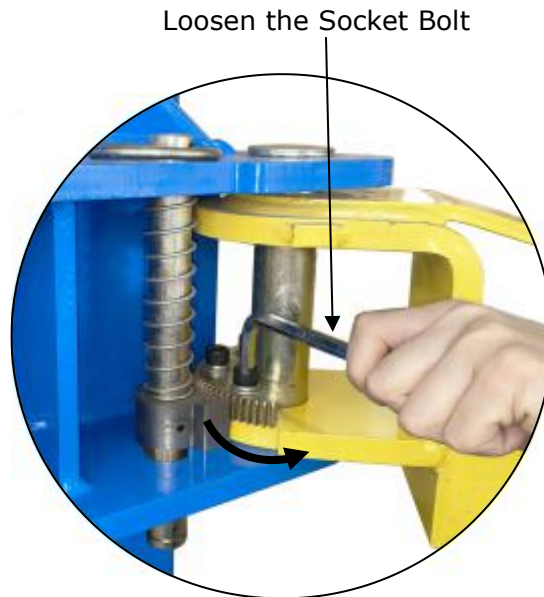

Fig. 36
Use the 10# Socket Head Wrench to loosen the Socket Bolt.

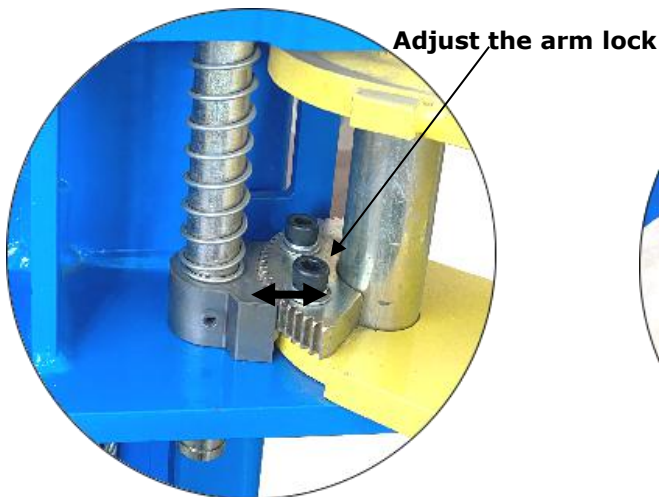

Fig. 37
Adjusting moon gear and arm lock to mesh.

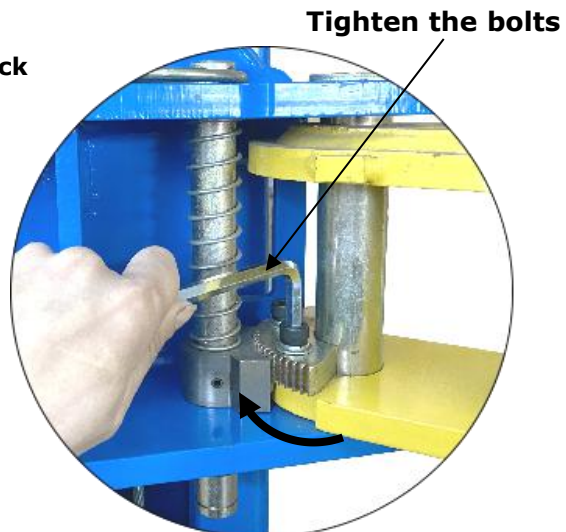

Fig. 38
Locking the bolts after the moon gear and arm lock engaged well.

Q. Tighten all the hydraulic fittings, and fill the reservoir with hydraulic oil.

Note: In consideration of Hydraulic Power Unit's durability and keep the equipment running in the perfect condition, please use Hydraulic Oil 46#.

R. Install electrical system

Connect the power source on the data plate of Power Unit.

Note: 1. For the safety of operators, the power wiring must contact the floor well.

2. Pay attention to the direction of rotations when using three phase motors.

Single phase motor.(See Fig.38)

1. When power supply wires are active wire L and neutral wire N ,connecting active wire L to terminals of AC contactor marked L1, connecting neutral wire N to terminals of AC contractor marked L3.
2. When power supply wires are two active wire L ,connecting to terminals of AC contactor marked L1, L3 respectively.
3. Connecting the limit switch: Remove the short wire connecting terminal 4# of control button and A2 of AC contactor firstly (See Fig. 41), then connect wire C#(black wire) of limit switch with terminal 4# of control button and connecting wire NC#(red wire) with terminals A2 of AC contactor respectively. (See Fig. 39)

The interior wire of limit switch connecting NC# and C#, refer to Step H.

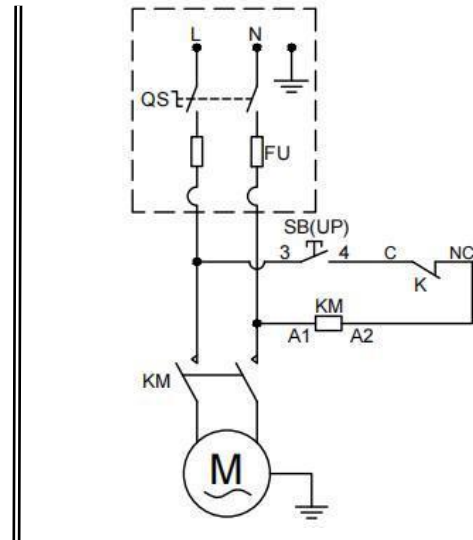
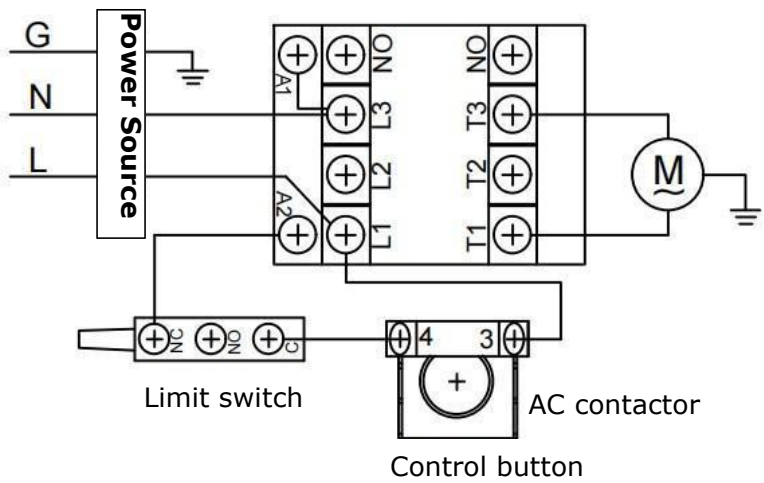

Fig. 39

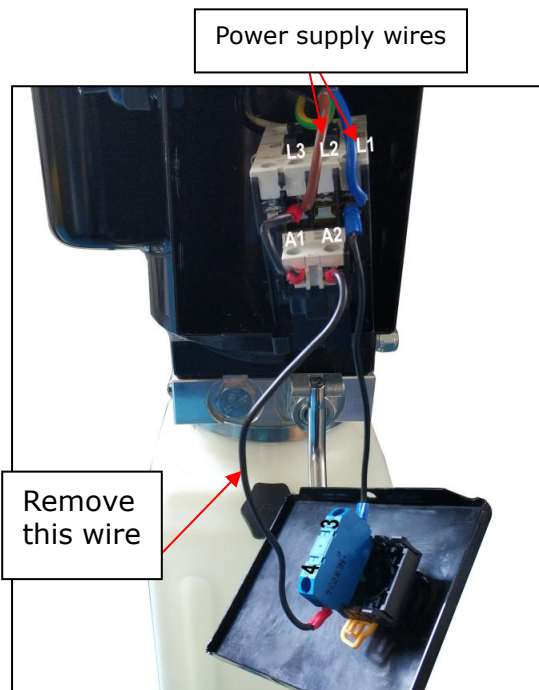

Fig. 40

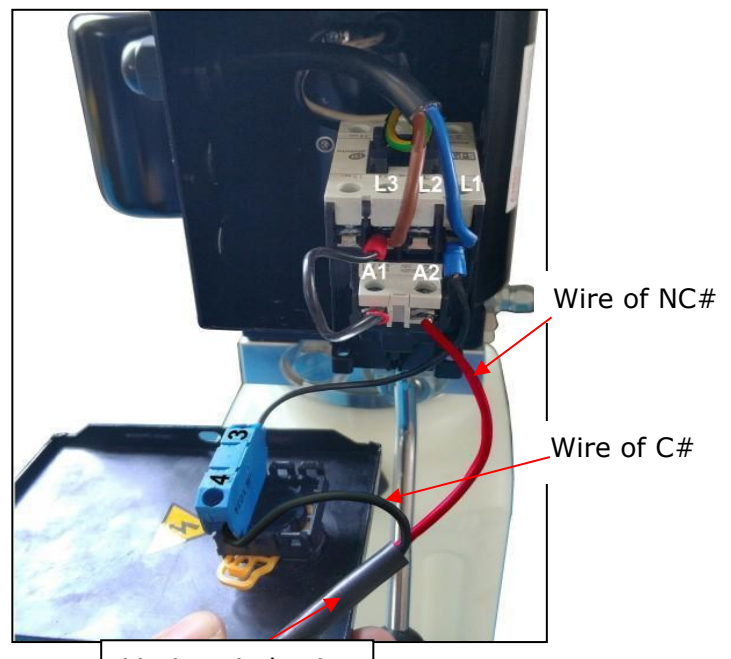

Fig.41

Three phase motor

1. Circuit diagram (See Fig. 41)

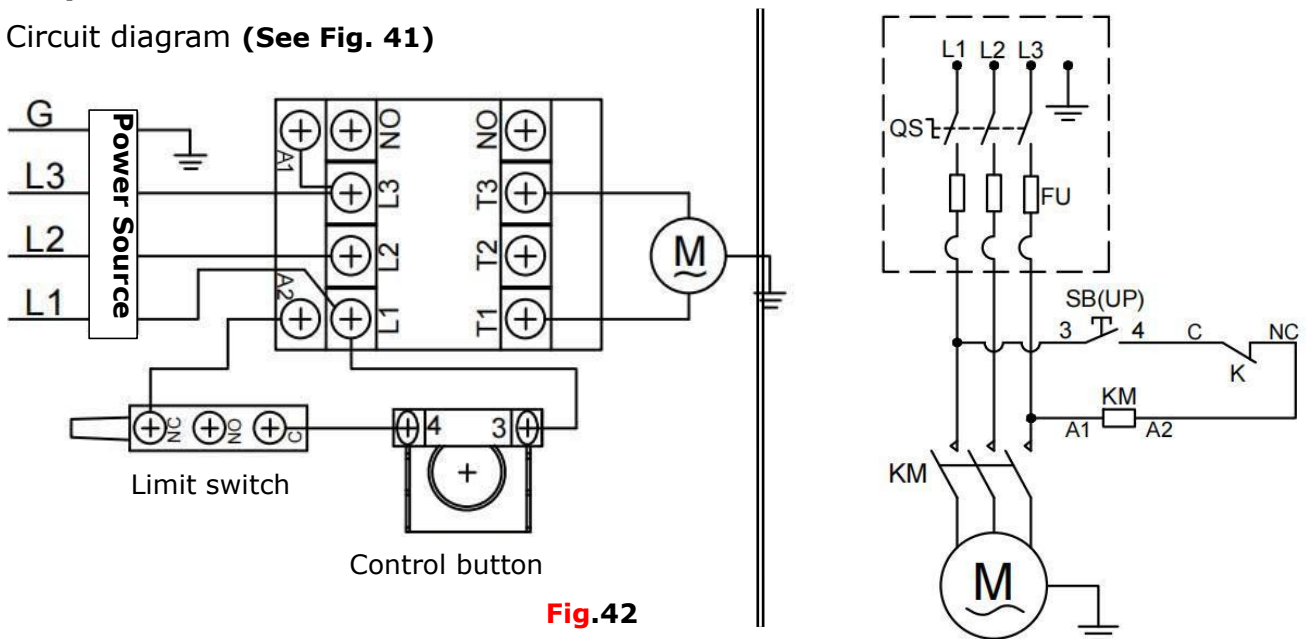

Fig.42

2. Connection step (See Fig.43)

- The power supply wires(L1, L2, L3) are connected with terminals of AC contactor marked L1, L2, L3 respectively.
- Remove the jumper wire which connect with terminal 4# of switch button and terminal A2# of AC contactor.
- Wire of limit switch C#(Black wire) connect to terminal 4# of switch button. Wire NC#(Red wire) connect to terminal A2# of AC contactor.
- Terminals 3# of switch button connect with L1 terminals of AC contactor.

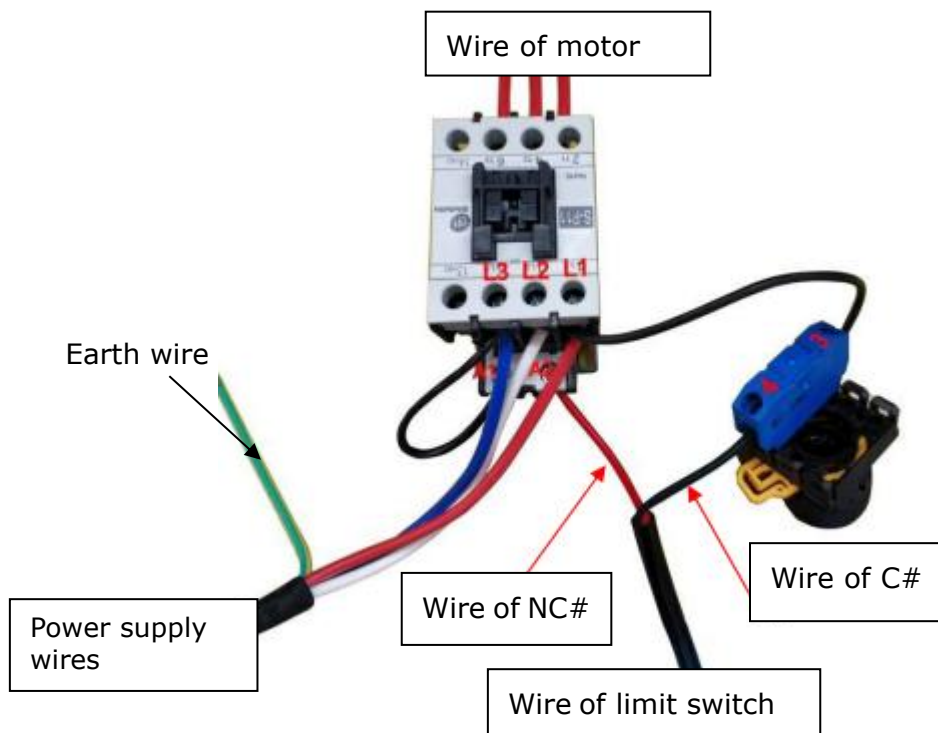

Fig. 43

IV. EXPLODED VIEW

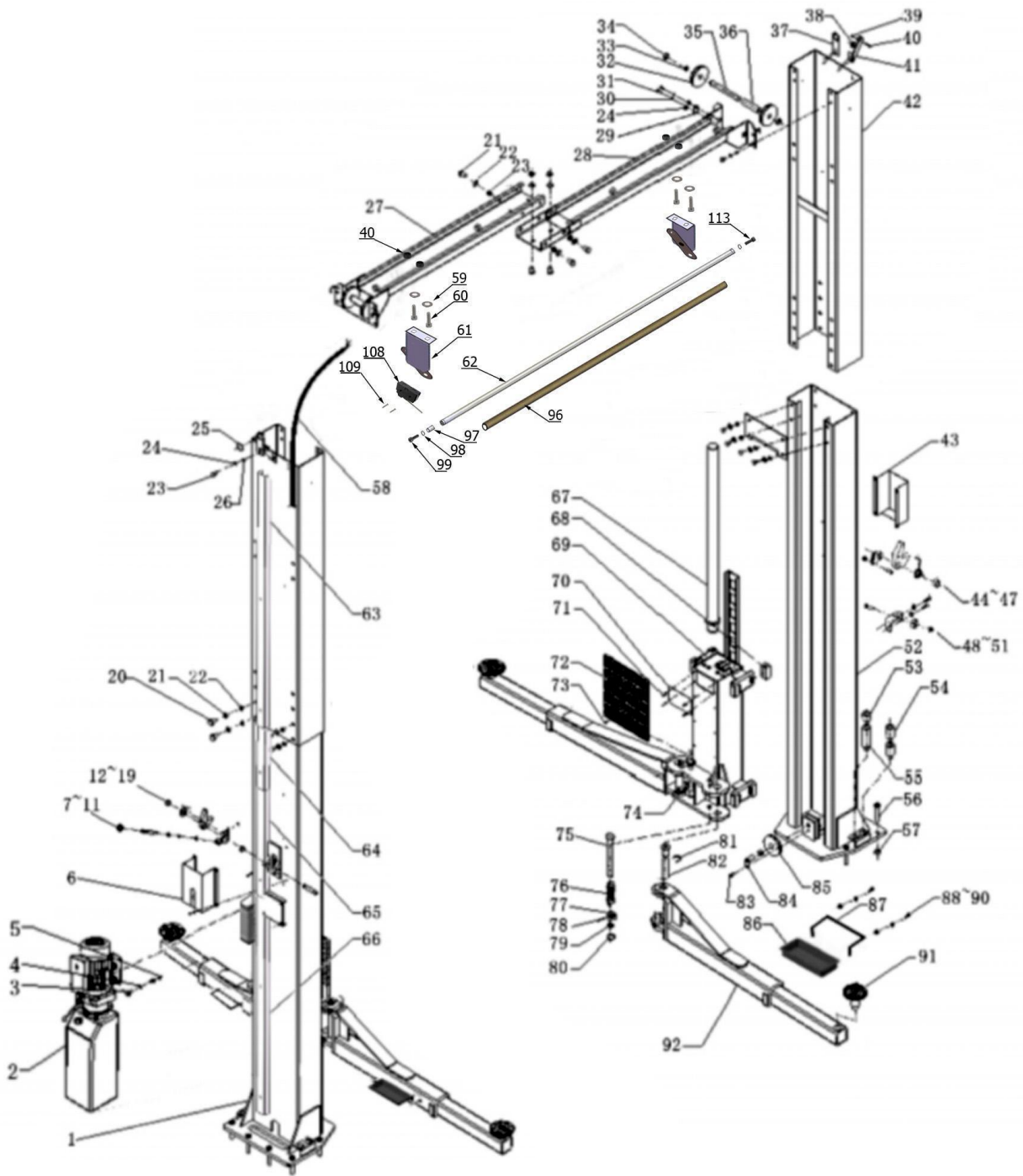

Fig. 44

PARTS LIST FOR MODEL CL6800C

Item	Part#	Description	QTY	NOTE
1	11217466	Power-side column	1	
2	81513003	Power unit 220V/50Hz/1 Phase	1/1	
	81513004	Power unit 380V/50Hz/3 Phase		
3	10209003	Hex Bolt M8*25	4	
4	10209033	Washer φ8	4	
5	10217002	Hex Nut M8	4	
6	11217405	Power-side safety cover	1	
7	11217005	Plastic ball M10	1	
8	11217006	Lock handle	1	
9	10206023A	Hex nut M12	1	
10	10420026	Lock washer φ12	1	
11	11217004	Main cam lock	1	
12	11217436	Large spacer φ36*15.5	2	
13	10217030	Main spring φ2.5*120°	2	
14	11217009	Main lock	1	
15	10217010	Hex bolt M6*40	1	
16	10217011	Hex nut M6	1	
17	11217012	Safety spacer φ27*10	2	
18	10217051	Socket bolt M10*10	2	
19	11217050	Safety pin	2	
20	10420018	Self locking nut M6	8	
21	10217069	Hex bolt M12*30	30	
22	10206006	Washer φ12	31	
23	10206023	Nylok nut M12	30	
24	10420045	Washer φ6	38	
25	1061K074	Protective ring	2	
26	10217013	Hex bolt M6*20	8	
27	11217016B-01	Top Beam Assy. (Left)	1	
28	11217015B-01	Top Beam Assy. (Right)	1	
29	11420044	Limit plate	2	
30	10209149	Lock washer φ6	12	
31	10420138	Socket bolt M6*16	4	
32	11217019	Top pulley	4	
33	10217020	Bronze bush for pulleyφ31*φ25.1*16	6	
34	11217021	Top Pulley Spacer (Short)	4	
35	11217022	Pin for Top Pulley	2	
36	11217023	Pin Spacer (Long)	2	
37	11217024	Oil Hose Support Plate	2	
38	10206009	Plastic Small Pulley P005A-2	3	
39	10209056	Nylok nut M10	3	
40	10209046	Hex Bolt M10*35	3	
41	11217379	Safety Cable Bracket	2	
42	11217471	Outer Column (L=2356mm)	2	
43	11217406	Off-side safety cover	1	
44	10217008	Safety Spring φ2.5*145°	1	

Item	Part#	Description	Qty.	Note
45	11217031	Off-side cam Lock	1	
46	10217032	Cable lock hold	1	
47	10217033	Self locking Nut	1	
48	10620079	Straight fitting (Only for high setting)	1	
49	1002185001-01	Oil hose assy. (Only for high setting)	1	
50	11217029	Small Pulley Bracket	1	
51	10217066	Hex Bolt M6*15	3	
52	11217467	Off-side Column	1	
53	11209051B	Adapter 1.5"	4	
54	11209052B	Adapter 2.5"	4	
55	11209053B	Adapter 5"	4	
56	10201140	Anchor bolt 3/4 " *6-1/2	12	
57	10620065	Shim(2mm)	10	
	10201090	Shim(1mm)	10	
58	10217454	Wire Cable L=5200	1	
59	10209022	Flat ϕ 10	1	
60	10209125	Cap Head Bolt M10*30	2	
61	1103072003A	Control Bar Support Bracket	1	
62	1102072001A	Control Bar ϕ 22*2400	2	
63	11217478	Wire Protective cover L=2230mm	2	
64	10206110	M6*35 cup head bolt	6	
	10206079	M6*40 cup head bolt	10	
65	11217473	Wire Protective cover L=1143mm(High setting)	2	
	11217477	Wire Protective cover L=531mm(Low setting)	2	
66	11217880	Wire Protective cover L=1320mm	1	
	11217895	Wire Protective cover L=1320mm	1	
67	10217056A	Cylinder ϕ 55*1727	2	
68	10217188	Slider block	16	
69	11217480	Carriage	2	
70	11217054	Carriage Plastic Cover	2	
71	10209009	Cup Head Bolt	8	
72	10217053	Protective Rubber	2	
73	10209019	Flat Head Screw M6*16	12	
74	11217046C	Arm Lock Bar(Right) ϕ 30*324.5	2	
75	11217046B	Arm Lock Bar(Left) ϕ 30*324.5	2	
76	10217045A-01	Spring ϕ 31* ϕ 36* ϕ 2.5(L=214.5)	4	
77	1002163001	Arm Lock M1.5*72*24	4	
78	10206036-01	Hair pin ϕ 6*45	4	
79	1102163002	Washer (ϕ 39*4*18)	8	
80	10610008	Snap ring ϕ 30	4	
81	10520023	Snap ring ϕ 38	4	
82	11217047B	Arm Pin	4	
83	10209038	Hex Bolt M10*16	6	
84	11217037	Bottom pulley Pin	2	
85	11217036	Bottom Pulley	2	

Item	Part#	Description	Qty.	Note
86	10206156	Tool tray	2	
87	11206154	Rear guard bar	4	
88	10201002	Hex bolt M8*16	8	
89	10209034	Lock Washer φ8	8	
90	10209033	Washer φ8	8	
91	10217114A	Rubber pad assy.	4	
91A	10420138	Socket bolt M6*16	12	
91B	10209134	Rubber Pad	4	
91C	11680030B	Rubber Pad Frame	4	
92	10217052D	Lifting Arm Assy.	4	
93	1102186001	Extend Straight Fitting(J0076) 1/4JIC(M)*3/8NPT(M)	2	
94	10209153	Straight Fitting φ70*φ6	2	
95	11217068	Column Reinforce Plate	2	
96	10206025A	Foam tube of control bar φ35*φ22*1950mm	1	
97	110207007	Connecting Bush φ14 *2*20	1	
98	10209039	Lock Washer φ10	2	
99	10630100	Socket bolt M10*40	1	
100	10209009	Cup Head Bolt	8	
101	10209066	Cable nut M16	8	
102	10217452	Cable Assy. φ9.52*12540mm	2	
103	10420029	Cable shim φ16	4	
104	10211016	T-Fitting 1/4JIC(M)*1/4JIC(M)*1/4JIC(M)	1	
105	10217455-01	Oil hose Assy. 5/16*6125mm	2	
106	10217456-01	Oil hose Assy. 5/16*5130mm	1	
107	10209060	90 °fitting for power unit	1	
108	1002022001	Limit switch CZ-7120	1	
109	10420164	Cup Head Bolt M4*30	2	
110	10217453	Safety Cable L=10370mm	1	
111	10217502B	Parts box	1	
112	1102075001	Cable restrain plate	4	
113	10720002	Socket bolt M10*25	1	

1. Lifting Arm Exploded View (10217052D)

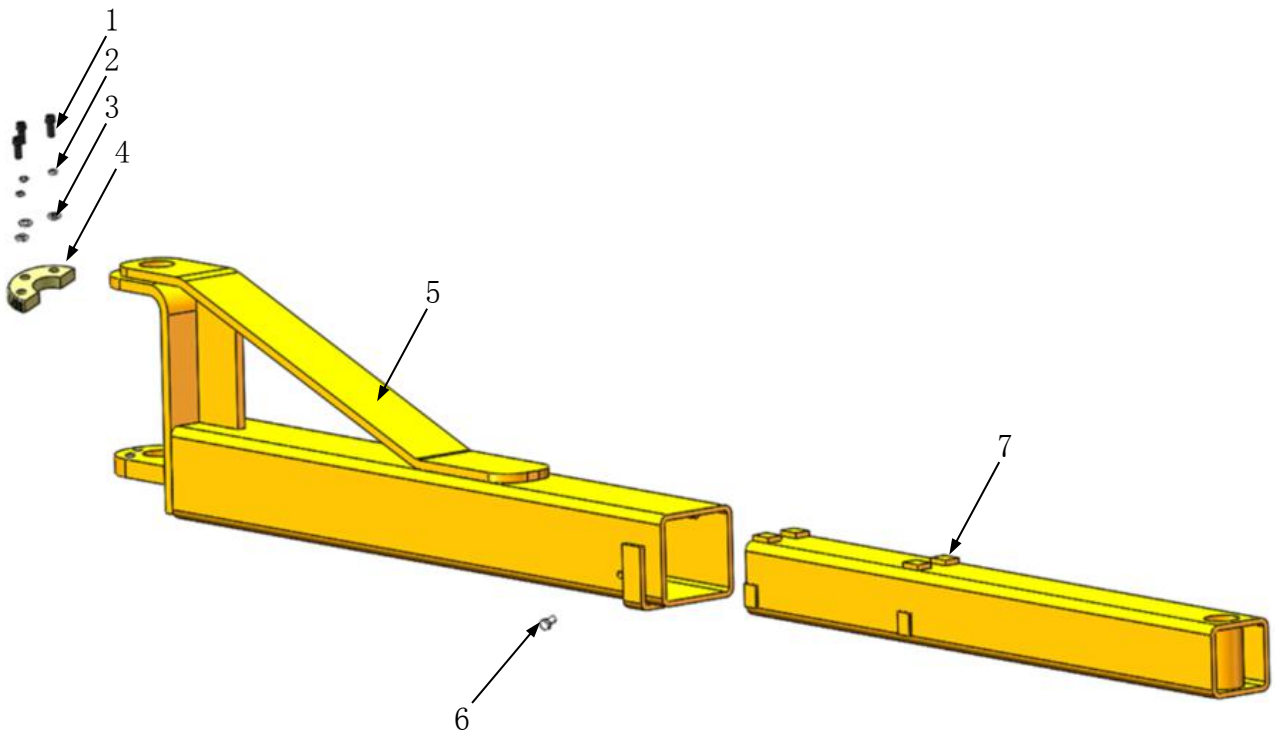

Fig. 45

Item	Part#	Description	Qty.	Note
1	1102163005	Socket bolt M12*48	12	
2	10420026	Lock washer ϕ 12	12	
3	10206006	Washer ϕ 12	12	
4	1102163001	Moon gear	4	
5	11217122	Outer rear arm	4	
6	10201149	Flat head screw M8*12	4	
7	11217123A	Inner arm	4	

2. Cylinders Exploded View (10217056B)

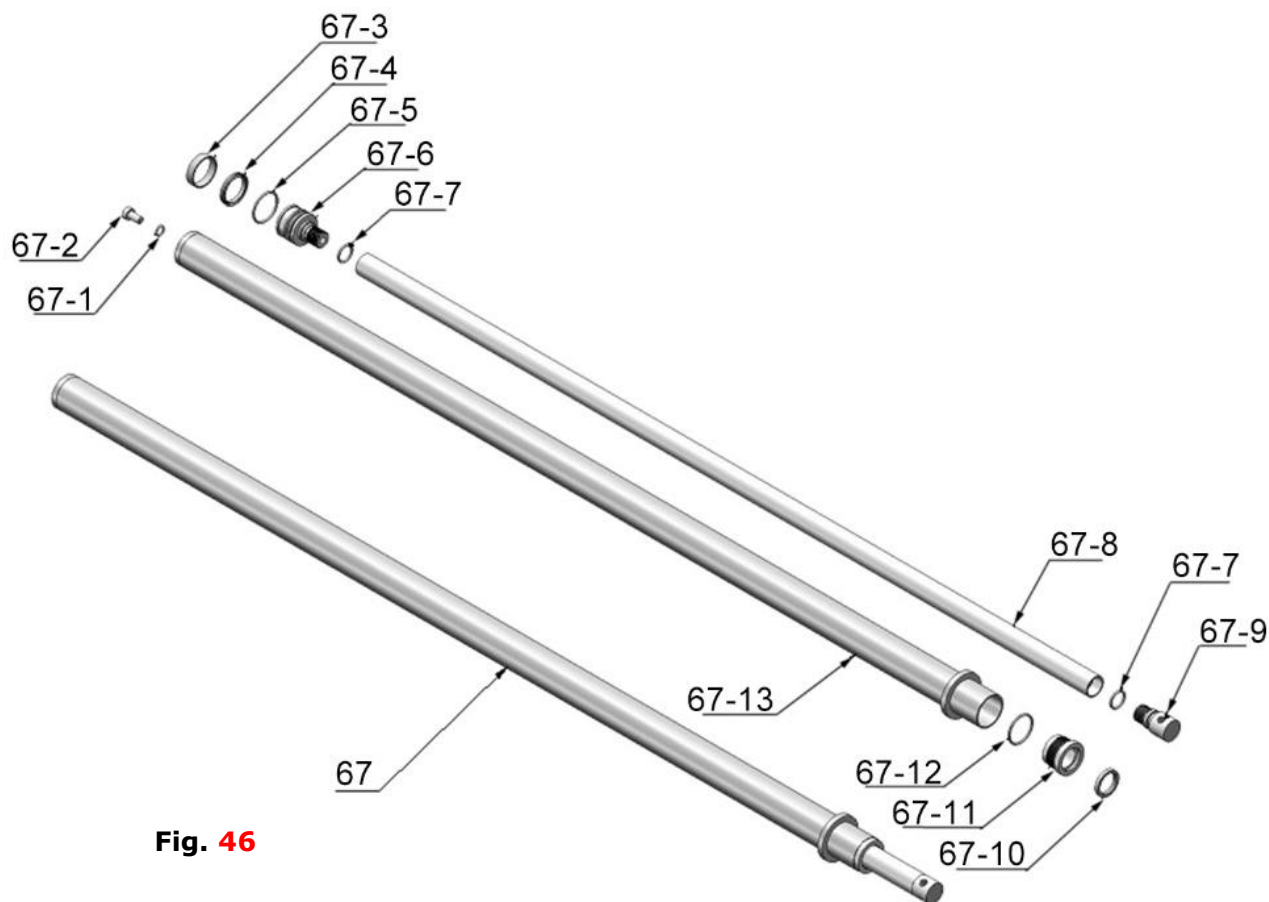

Fig. 46

Item	Part#	Description	Qty.	Note
67-1	10209069	O-Ring	2	
67-2	10209070	Bleeding Plug	2	
67-3	10201029	Support Ring	2	
67-4	10201030	Y-Ring	2	
67-5	10201031	O-Ring	2	
67-6	11217074A	Piston	2	
67-7	10217075	O-Ring	2	
67-8	11217089	Piston rod	2	
67-9	11217077	Piston rod fitting	2	
67-10	10217078	Dust ring	2	
67-11	11217079	Head cap	2	
67-12	10217080	O-Ring	2	
67-13	11217091	Bore weldment	2	

3. Manual power unit Explode View (81513003/81513004)

220V/50Hz, Single Phase

380V/50Hz, 3 Phase

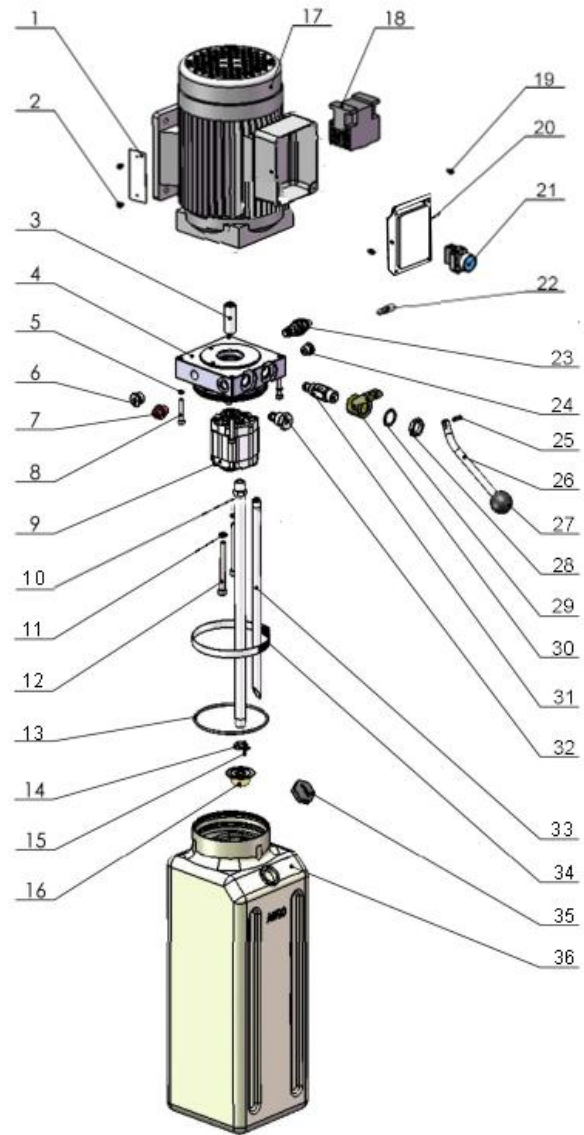
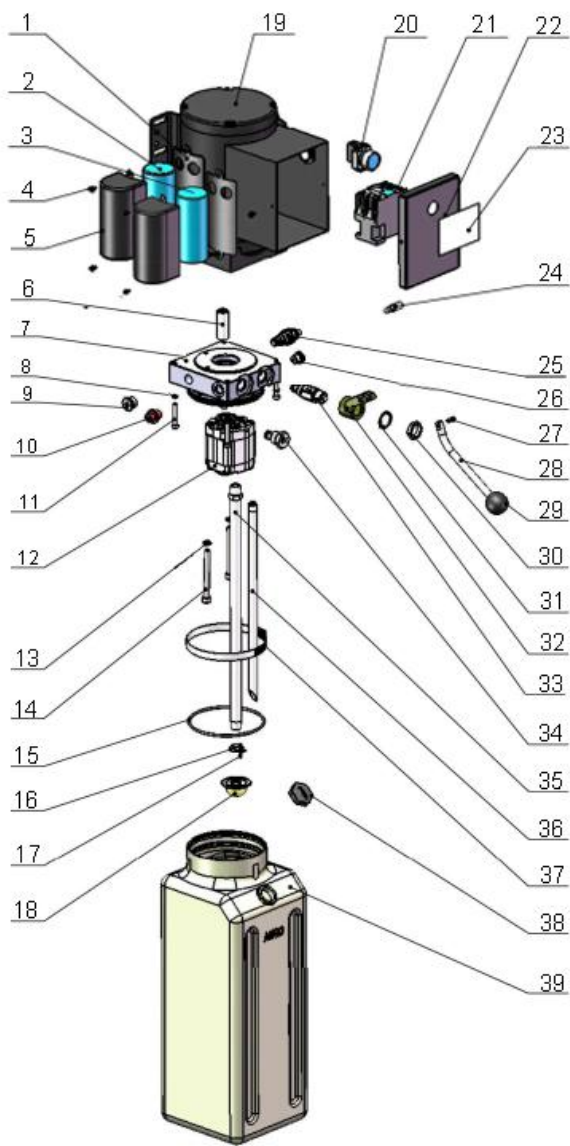

Fig. 47

Parts For Manual Power Unit 220V/50Hz/Single phase (81513003)				
Item	Part#	Description	Qty.	Note
1	81400180	Rubber Pad	2	
2	81400250	Starting capacitor	1	
3	81400200	Running capacitor	1	
4	10420148	Cup Head Bolt with washer	4	
5	81400066	Cover of Motor Terminal Box	2	
6	81400363	Motor Connecting Shaft	1	
7	80101013	Manifold block	1	
8	10209149	Washer	4	
9	81400276	Iron plug	1	
10	81400259	Red rubber plug	1	
11	85090142	Socket bolt	4	
12	81400158	Gear pump	1	
13	10209034	Washer	2	
14	81400295	Socket bolt	2	
15	81400365	O ring	1	
16	10209152	Ties	1	
17	85090167	Magnet	1	
18	81400290	Filter	1	
19	81400413	Steel Motor	1	
20	10420070	Push button	1	
21	41030055	AC connector	1	
22	81400287	Motor terminal box cover	1	
23	71111171	AMGO power unit label	1	
24	81400560	Throttle valve	1	
25	81400266	Relief valve	1	
26	81400284	Inner hex iron plug	1	
27	10720118	Hair pin	1	
28	81400451	Release valve handle	1	
29	10209020	Plastic ball	1	
30	81400421	Release valve nut	1	
31	81400422	Shim	1	
32	81400447	Valve Seat	1	
33	81400567	Release Valve	1	
34	81400560	Check Valve	1	
35	81400366	Oil suction pipe	1	
36	81400367	Oil return pipe	1	
37	81400364	Clamp	1	
38	81400263	Oil tank cap	1	
39	81400319	Oil tank	1	

Parts For Manual Power Unit 380V/50Hz/3 phase (81513004)			
Item	Part#	Description	Qty
1	71150022	AMGO Nameplate	1
2	81400300	Cup Head Bolt	2
3	81400363	Motor Connecting Shaft	1
4	80101013	Manifold block	1
5	10209149	Washer	4
6	81400276	Iron plug	1
7	81400259	Red rubber plug	1
8	85090142	Socket Bolt	4
9	81400307	Gear pump	1
10	81400366	Oil suction hose	1
11	10209034	Washer	2
12	81400295	Socket bolt	2
13	81400365	O ring	1
14	10209152	Ties	1
15	85090167	Magnet	1
16	81400290	Filter	1
17	81400309	Motor	1
18	81400348	AC connector	1
19	10420148	Cup head bolt	2
20	81400481	Motor Terminal Box cover	1
21	10420070	Push Button	1
22	81400560	Throttle valve	1
23	81400266	Relief Valve	1
24	81400284	Iron plug	1
25	81400452	Pin	1
26	81400451	Release Valve Handle	1
27	10209020	Plastic Ball	1
28	81400421	Release Valve Nut	1
29	81400422	Self Lock washer	1
30	81400447	Valve Seat	1
31	81400567	Release Valve	1
32	81400560	Check Valve	1
33	81400367	Oil Return Hose	1
34	81400364	Clamp	1
35	81400263	Oil tank cover	1
36	81400319	Oil tank	1

Illustration of hydraulic valve for hydraulic power unit (See Fig. 48)

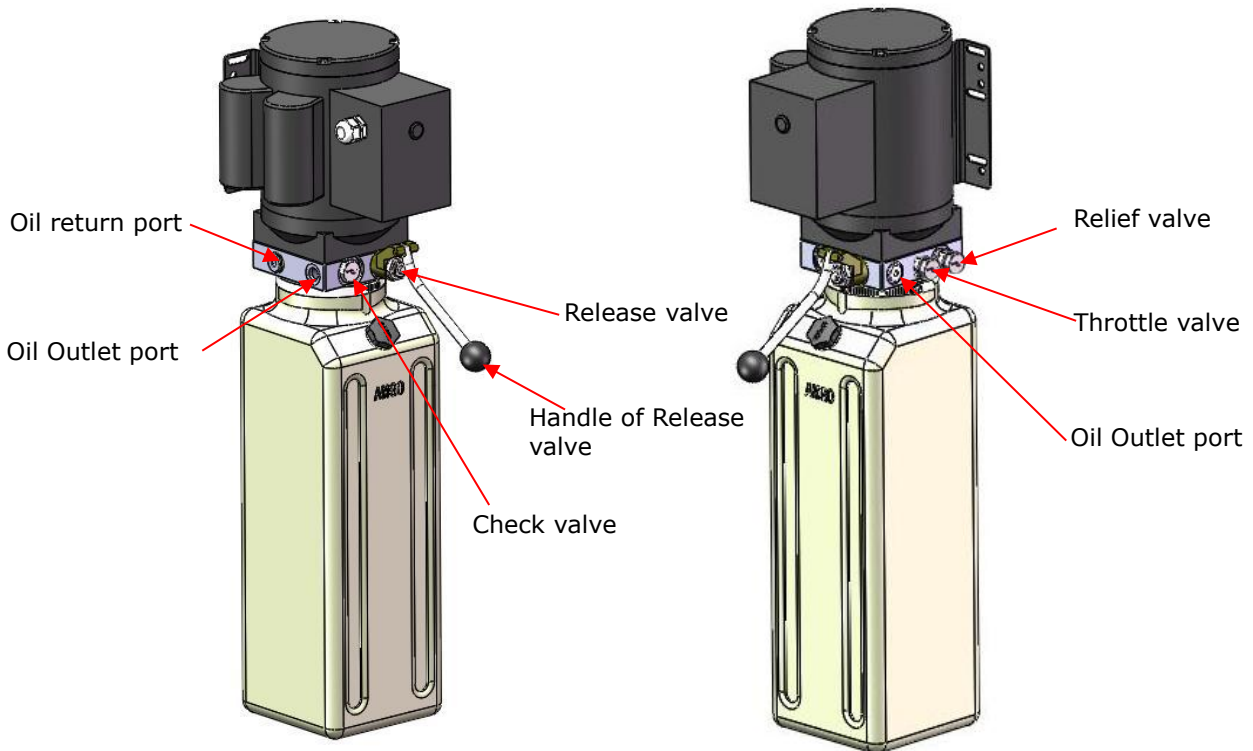

Fig. 48

V. TEST RUN

1. Adjustment of synchronous cable (See Fig. 49)

Use wrench to hold the cable fitting, meanwhile using ratchet spanner to tighten the cable nut until the two cables are in the same tension.

If the two vehicle carriages do not Synchronized when lifting and lowering, please screw and tighten the cable nut on the lower side carriage.

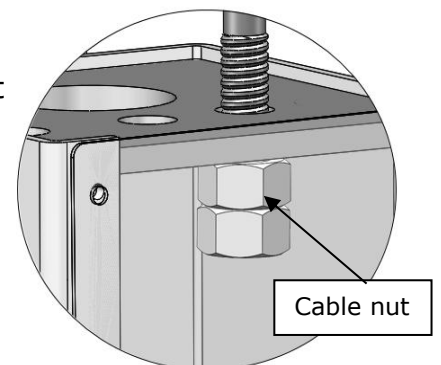

Fig. 49

2. Adjust safety cable

Rise the vehicle carriages and lock them at the same height, strain the safety cable and then release a little, and then tighten the safety cable nuts. Make sure the safety device can always lock the carriages properly. At last, install the plastic cover of the safety device.

3. Bleeding air from oil cylinder (See Fig. 50)

This hydraulic system is designed with a bleeding plug, located at the top of the cylinder, Raise the carriages to about 1 meter height and loose the bleeding plug, the air would be discharged automatically, then tighten the plug after bleeding air, the lift would work stably and smoothly, otherwise, repeat bleeding air.

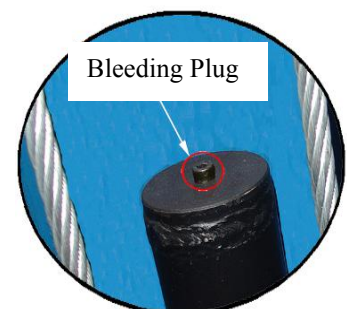
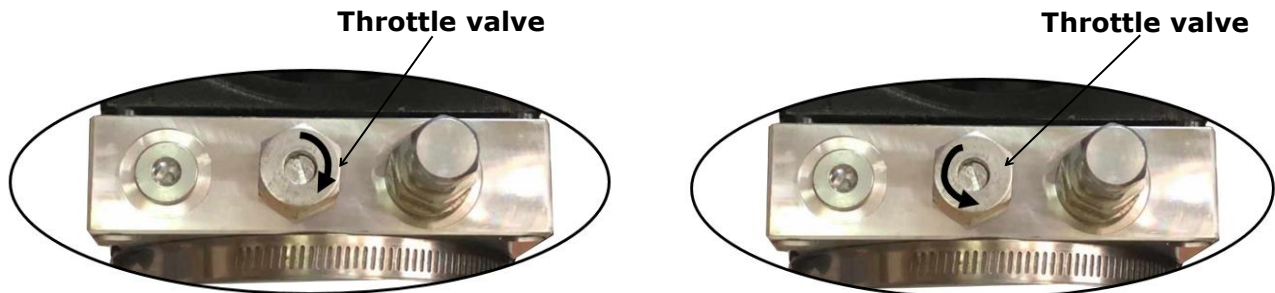

Fig. 50

4. Adjust the lowering speed

You can adjust the lowering speed of the lift if needing: screw the throttle valve clockwise to decrease the lowering speed, or counterclockwise to increase the lowering speed.



Adjust clockwise, decrease lowering speed

Counterclockwise, increase lowering speed

Fig. 51

5. Test with load

After finishing the above adjustment, test running the lift with load. Run the lift in low position for several times first, make sure the lift can rise and lower synchronously, the safety device can lock and release synchronously. And then test run the lift to the top completely. If there are anything improper, repeat the above adjustment.

NOTE: It may be vibrated when lifting at start, lifting it with load for several times, the air would be bled and the vibration would be disappeared automatically.

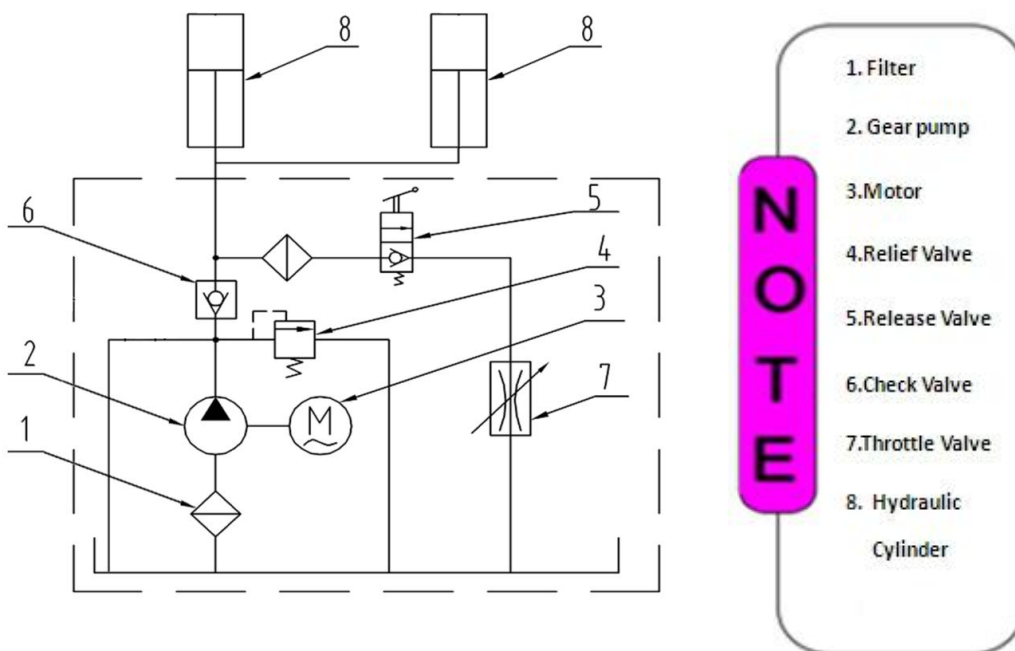

Fig. 52 Hydraulic System

VI. OPERATION INSTRUCTIONS

Please read the safety tips carefully before operating the lift

To lift vehicle

1. Keep clear of site near the lift;
2. Position lift arms to the lowest position;
3. To shortest lift arms;
4. Open lift arms;
5. Position vehicle between columns;
6. Move arms to the vehicle's lifting point;

Note: The four lift arms must at the same time contact the vehicle's lifting point where manufacturers recommended

7. Press button "**UP**" until the lift pads contact underside of vehicle totally. Recheck to make sure vehicle is secure;
8. Continue to raise the lift slowly to the desired working height, ensuring the balance of vehicle;
9. Push lowering handle to lower lift onto the nearest safety. The vehicle is ready to repair.

To lower vehicle

1. Be sure clear of around and under the lift, only leaving operator in lift area;
2. Press button "**UP**" to raise the vehicle slightly, and then release the safety device, lower vehicle by pushing lowering handle.
3. Open the arms and position them to the shortest length;
4. Drive away the vehicle.
5. Turn off the power.

VII. MAINTENANCE SCHEDULE

Monthly:

1. Re-torque the anchor bolts to 150 Nm;
2. Check all connectors, bolts and pins to insure proper mounting;
3. Lubricate cable with lubricant;
4. Make a visual inspection of all hydraulic hoses/lines for possible wear or leakage;
5. Check safety device and make sure proper condition;
6. Lubricate all rollers and pins with 90wt. Gear oil or equivalent;

Note: All anchor bolts should take full torque. If any of the bolts does not function for any reason, DO NOT use the lift until the bolt has been replaced.

Every six months:

1. Make a visual inspection of all moving parts for possible wear, interference or damage.
2. Check and adjust as necessary, equalizer tension of the cables to insure level lifting.
3. Check columns for plumbness.
4. Check rubber pads and replace as necessary.
5. Check safety device and make sure proper condition.

Oil cylinder maintenance:

In order to extend the service life of the oil cylinder, please operate according to the following requirements.

1. Recommend to use N46 anti-wear hydraulic oil.
2. The hydraulic oil of the lifts should be replaced regularly during using. Replace the hydraulic oil 3 months after the first installation, Replace the hydraulic oil once a year afterwards.
3. Make at least one full trip raising and lowering per day. For exhausting the air from the system, which could effectively avoid the corrosion of the cylinder and damage to the seals caused by presence of air or water in the system.
4. Protect the outer surface of the oil cylinder's piston rod from bumping and scratching, and timely clean up the debris on the oil cylinder dust-ring and the piston rod.

VIII. TROUBLE SHOOTING

TROUBLE	CAUSE	REMEDY
Motor does not run	<ol style="list-style-type: none"> 1. Button does not work 2. Wiring connections are not in good condition 3. Motor burned out 4. Height limit switch is damaged 5. AC contactor burned out 	<ol style="list-style-type: none"> 1. Replace button 2. Repair all wiring connections 3. Repair or replace motor 4. Replace the limit switch 5. Replace AC contactor
Motor runs but the lift is not raised	<ol style="list-style-type: none"> 1. Motor runs in reverse rotation 2. Gear pump out of operation 3. Release valve in damage 4. Relief valve or check valve in damage 5. Low oil level 	<ol style="list-style-type: none"> 1. Reverse two power wire 2. Repair or replace 3. Repair or replace 4. Repair or replace 5. Fill tank
Lift does not stay up	<ol style="list-style-type: none"> 1. Release valve out of work 2. Relief valve or check valve leakage 3. Cylinder or fittings leaks 	Repair or replace
Lift raises slowly	<ol style="list-style-type: none"> 1. Oil line is jammed 2. Motor running on low voltage 3. Oil mixed with air 4. Gear pump leaks 5. Overload lifting 	<ol style="list-style-type: none"> 1. Clean the oil line 2. Check electrical system 3. Fill tank 4. Replace pump 5. Check load
Lift cannot lower	<ol style="list-style-type: none"> 1. Safety device are in activated 2. Release valve in damage 3. Safety cable broken 4. Oil system is jammed 	<ol style="list-style-type: none"> 1. Release the safeties 2. Repair or replace 3. Replace 4. Clean the oil system

IX. Scarping of equipment:

When the car lift cannot meet the requirements for normal use and needs to be disposed, it should follow local laws and regulations.

CLASSIC LIFT