

CLASSIC LIFT

Installation And Service Manual

Original

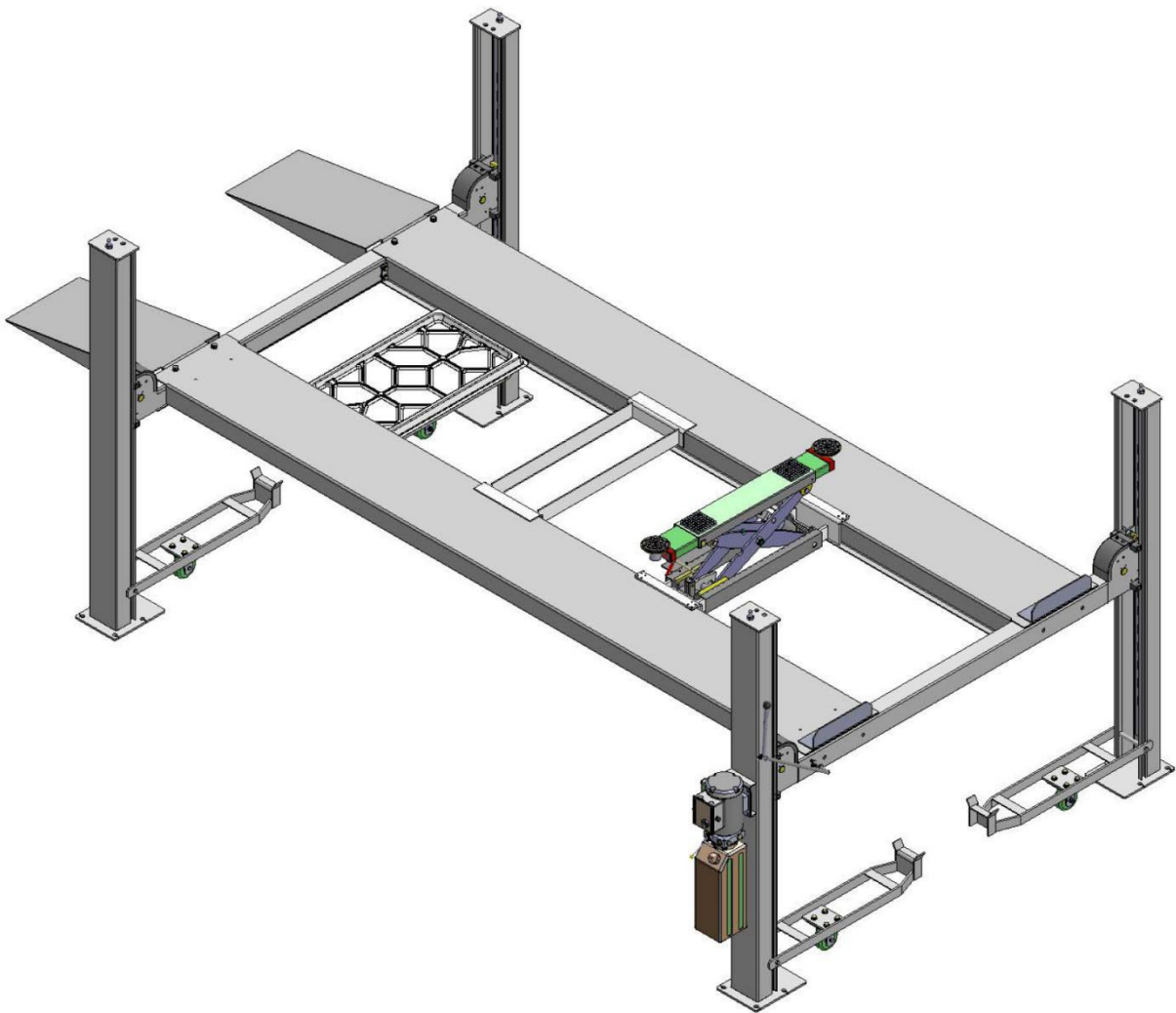

Four Post Parking lift
Model: CL3000-4P

CONTENTS

Product Features and Specifications	1
Installation Requirement	2
Steps of Installation	4
Exploded View	25
Test Run	33
Operation Instruction	34
Maintenance	34
Trouble Shooting	36
Scarping of equipment.....	36

I. PRODUCT FEATURES AND SPECIFICATIONS

4-POST MODEL CL3000-4P FEATURES

- Single cylinder drive, Cable drive.
- Single point manual safety release.
 - The primary safety device of automatic machinery and the secondary safety device of cable breaking in the process of rising ensure the safety of the vehicle.
- Power-side column can be installed at both side, front or rear.
- Non-skid diamond platforms and adjustable safety lock ladders.
- Optional kits: Sliding jack with hand pump, caster kits, plastic oil tray.

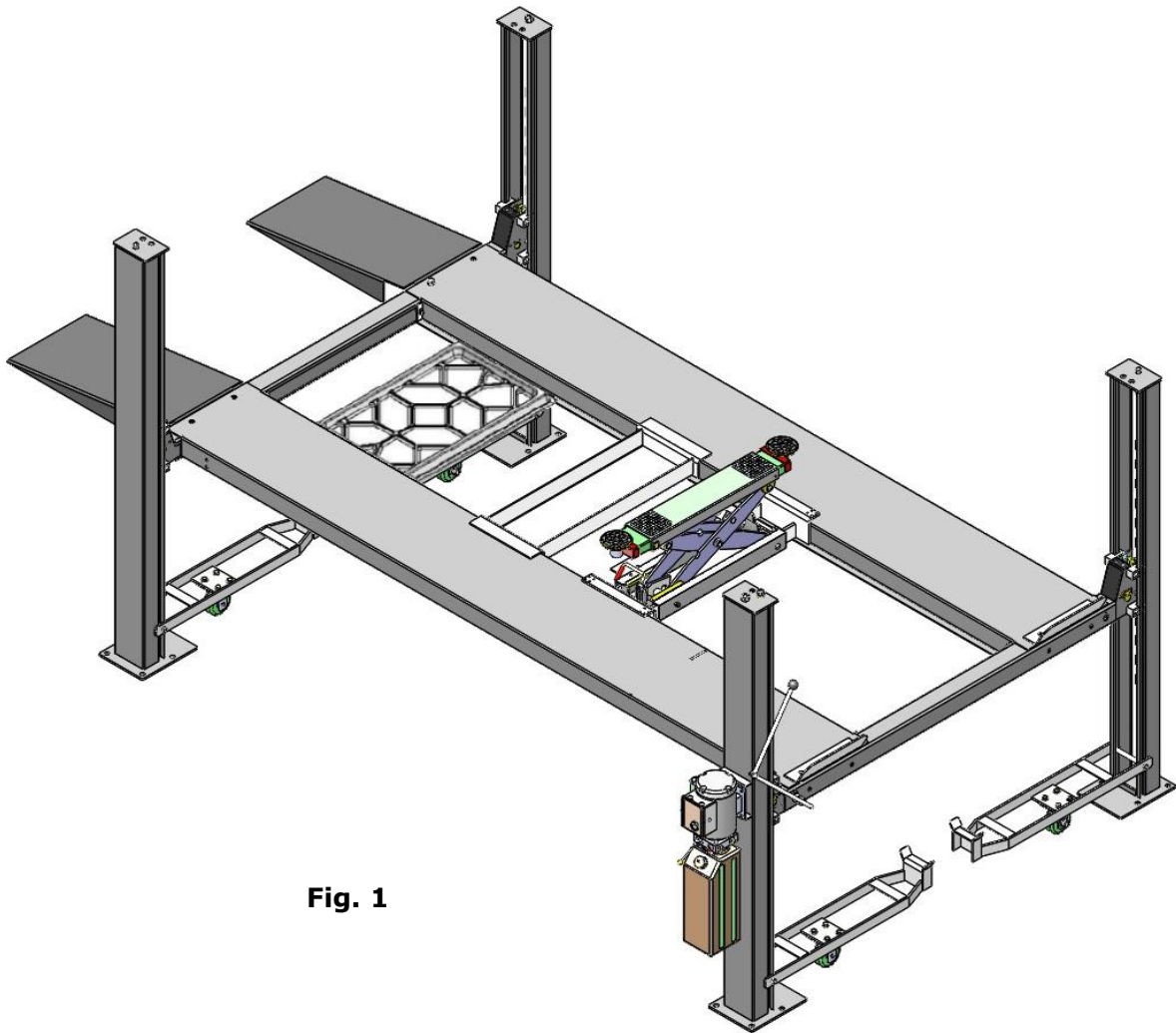

Fig. 1

MODEL CL3000-4P SPECIFICATIONS

Model	Lifting Capacity	Lifting Height	Lifting Time	Overall Length (Inc. Ramps)	Overall Width	Overall high	Width Between Columns	Motor
CL3000-4P	3200KG	1862mm	31S	4712mm	2509mm	2105mm	2167mm	110V: 1.5HP 220V: 3.0HP

II. INSTALLATION REQUIREMENT

A. TOOLS REQUIRED

- ↳ Tape Measure (7.5m) 
- ↳ Hammer 
- ↳ Level Bar 
- ↳ English Spanner 
- ↳ Wrench set: (12#, 13#, 14#, 15#, 17#, 19#, 24#, 30#)







- ↳ Carpenter's Chalk 
- ↳ Screw Sets 
- ↳ Pliers 
- ↳ Lock Wrench 
- ↳ Socket Head Wrench: (3#, 5#)

Fig. 2

B. Equipment storage and installation requirements.

The equipment should be stored or installed in a shady, normal temperature, ventilated and dry place.

C. The equipment should be unload and transfer by forklift.



Fig.3

D.SPECIFICATIONS OF CONCRETE (See Fig. 4)

Specifications of concrete must be adhered to the specification as following.

Failure to do so may result in lift and/or vehicle falling.

1. Concrete must be thickness 100mm minimum and without reinforcing steel bars, and must be dried completely before lift installation.
2. Concrete must be in good condition and must be of test strength 210kg/cm^2 (3,000psi) minimum.
3. Floors must be level and no cracks.

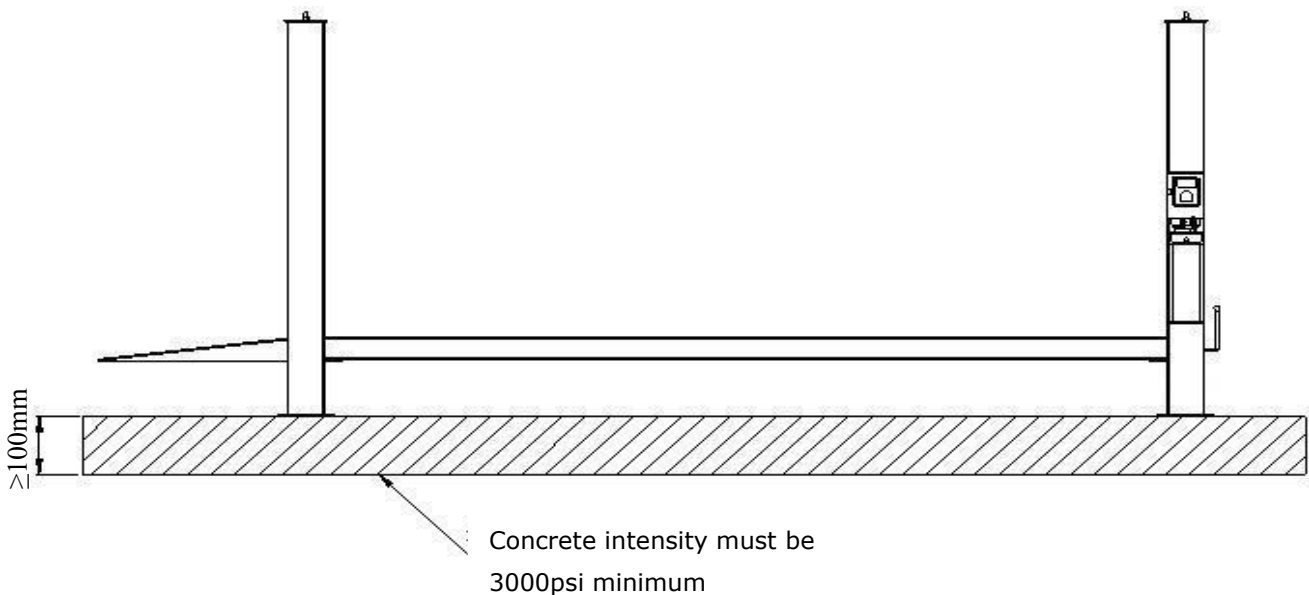

Fig.4

E. POWER SUPPLY

The electrical source must be 2.2kw minimum. The source cable size must be 2.5mm^2 minimum and in good condition of contacting with floor.

III. STEPS OF INSTALLATION

A. Check the parts before assembly

1. Packaged lift and Hydraulic Power Unit (See Fig. 5).



Fig. 5

Optional Plastic oil tray

2. Open the outer packing carefully, check the parts according to the shipment list. (See Fig. 6)

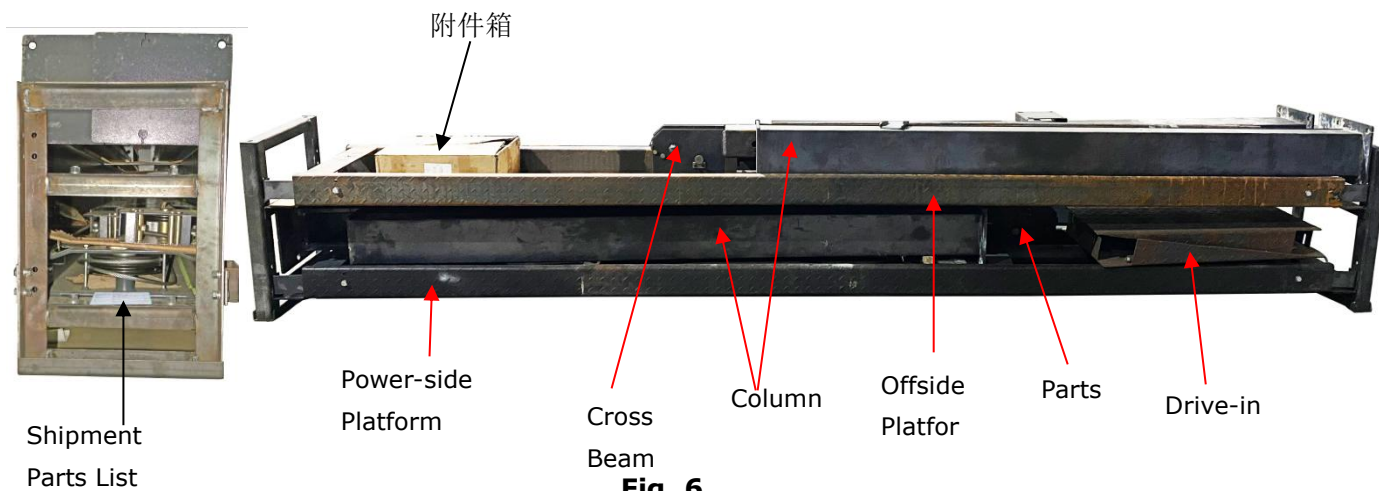

Fig. 6

3. Take off the drive-thru ramps and columns (See Fig.7).

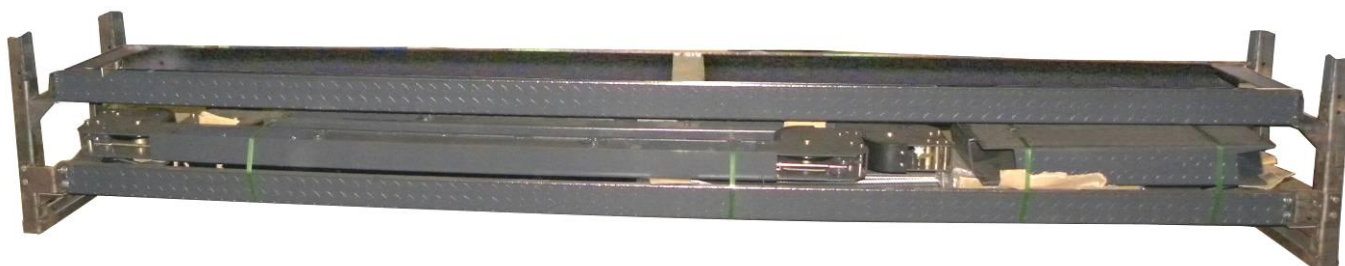

Fig.7

4. Loose the screws of the upper package stand, take off the offside platform, take out the parts inside the power-side platform, then remove the package stand.

5. Move aside the parts and check the parts according to the shipment parts list
(See Fig. 8).



Fig. 8

6. Open the carton of parts and check the parts according to the parts box list
(See Fig. 9)



Fig. 9

7. Check the parts of the parts bag according to the parts bag list (See Fig. 10).



B. Use a carpenter's chalk line to establish installation layout as per Table 1. Make sure the size is right and base is flat (see Fig. 11).

Note: Reserve space front and behind the installation site.

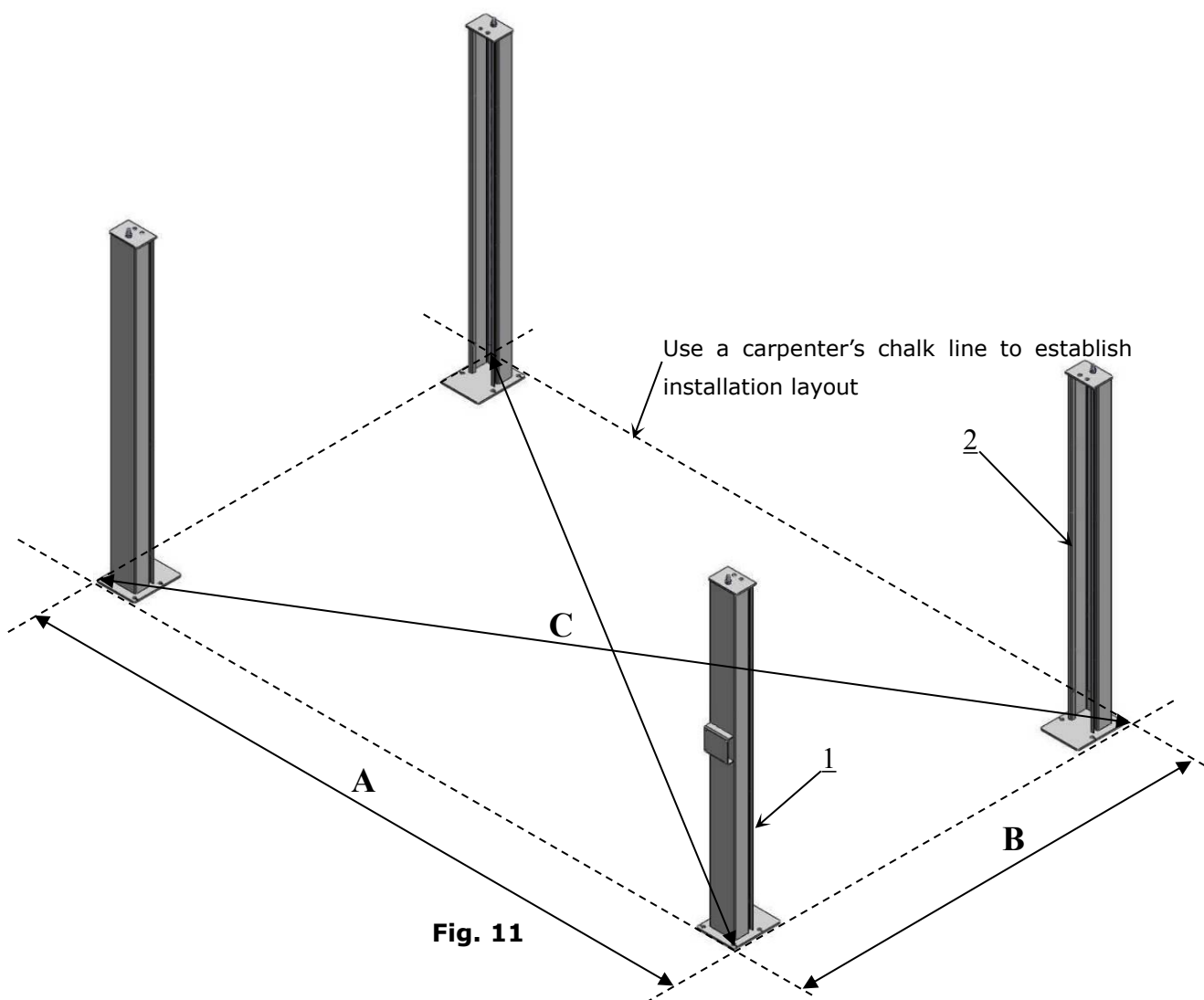

Fig. 11

MODEL	A	B	C
CL3000-4P	3862mm	2509mm	4605mm

C. Install cross beams (Note that Hole of the beam towards inside and the side with the rotating component of the safety mechanism should be the same side as the column where the power unit is installed. See Fig.12 & 13)

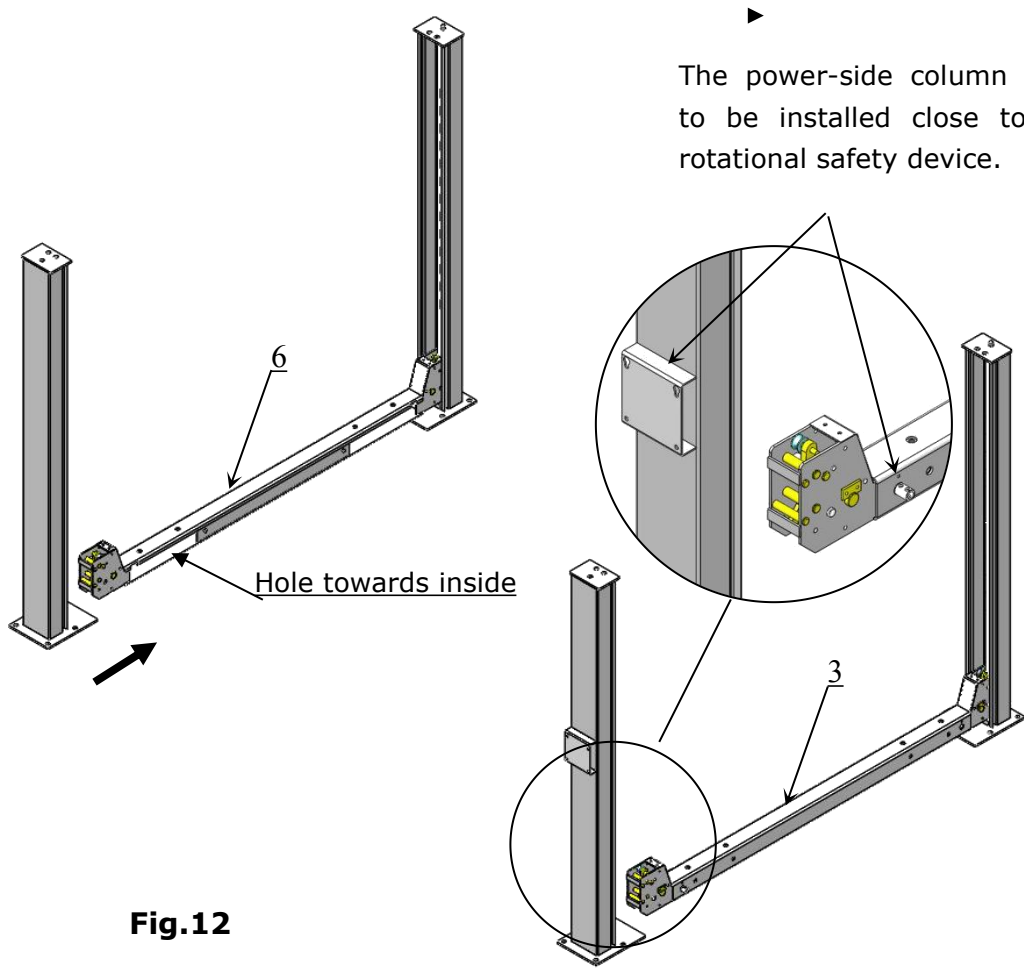

Fig.12

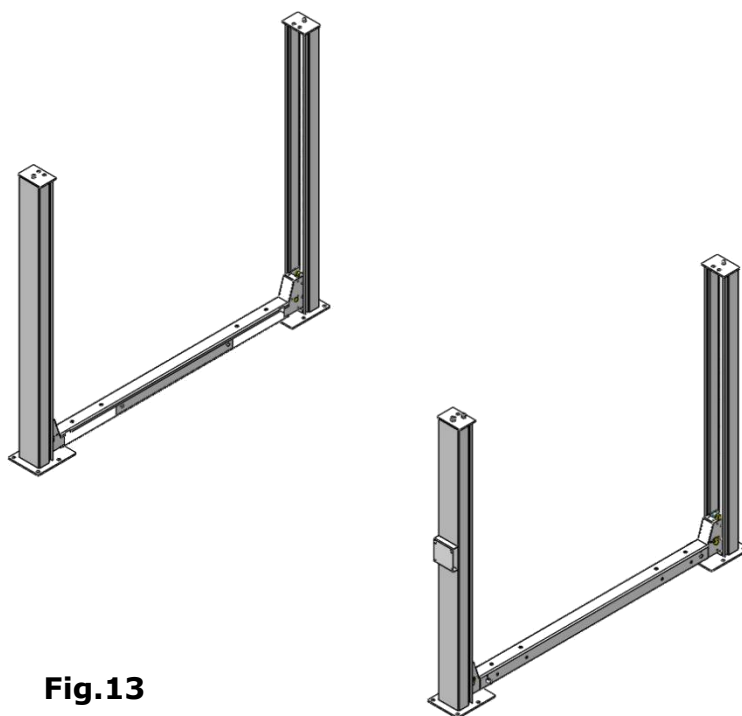

Fig.13

D. Install the Safety Ladders.

1. Take off the pulley safety cover and unscrew a nut of the safety ladders, and then adjust the four lower nuts to be at the same position. Then install the safety ladder (**See Fig. 14**).

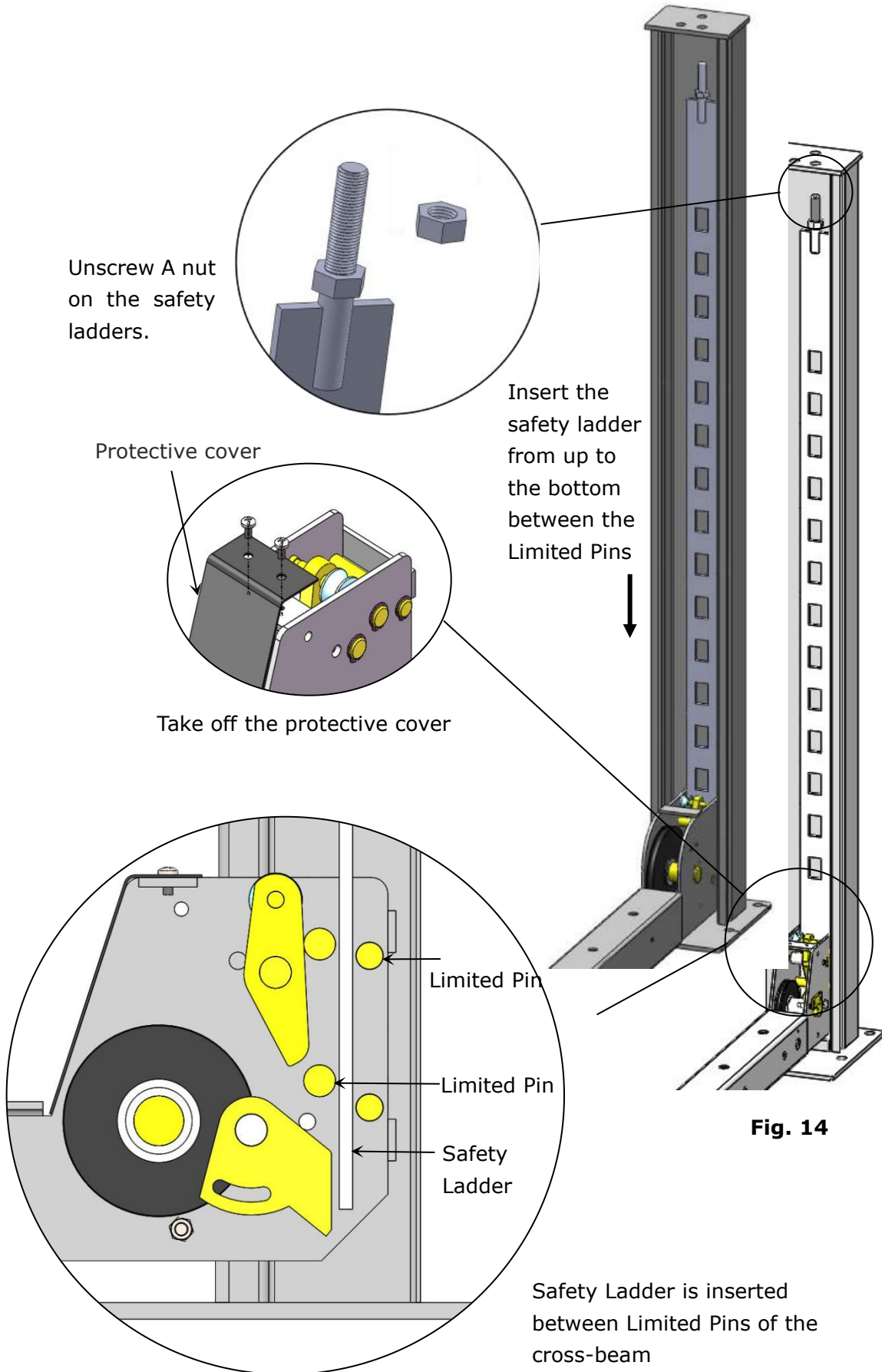
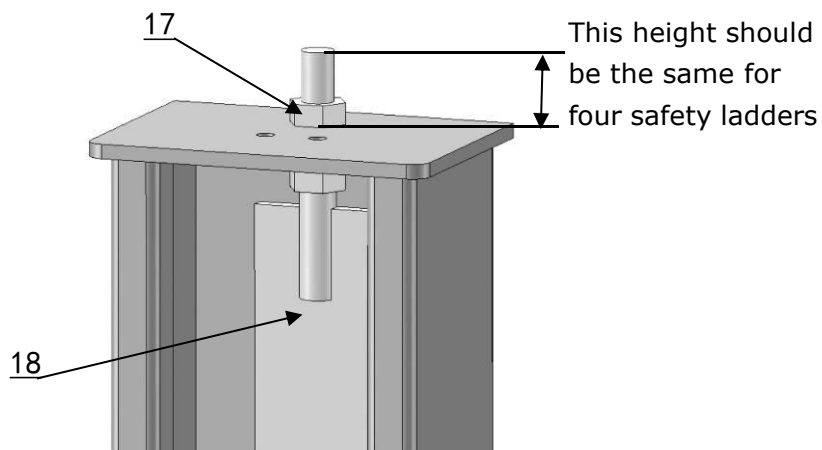

Fig. 14

2. Install Safety Ladders (See Fig. 15).



Safety ladder pass through the hole of the top plate, then tighten the two nuts

Fig. 15

E. Put the cross beams at the same height and lock on the safety ladder (See Fig. 16).

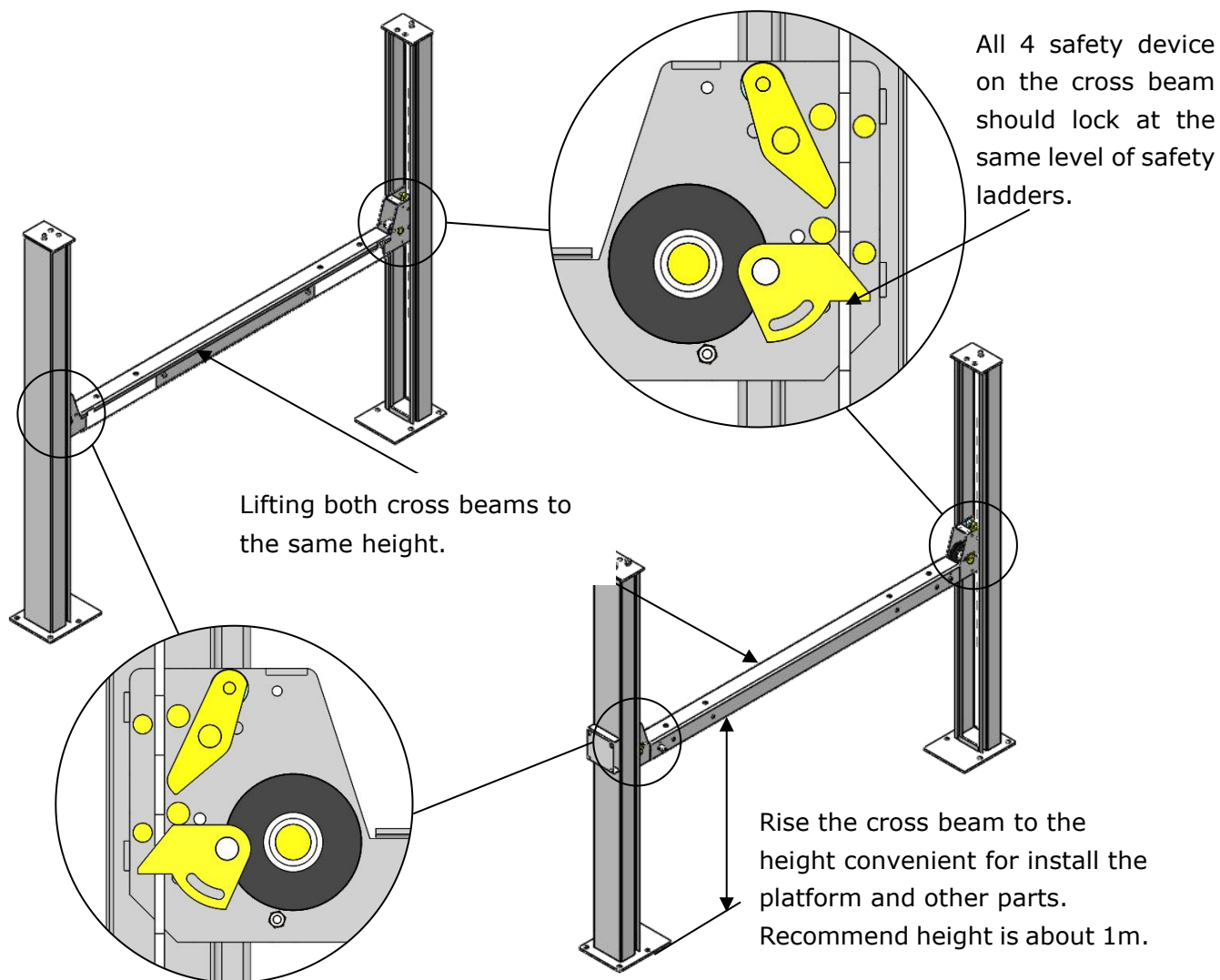
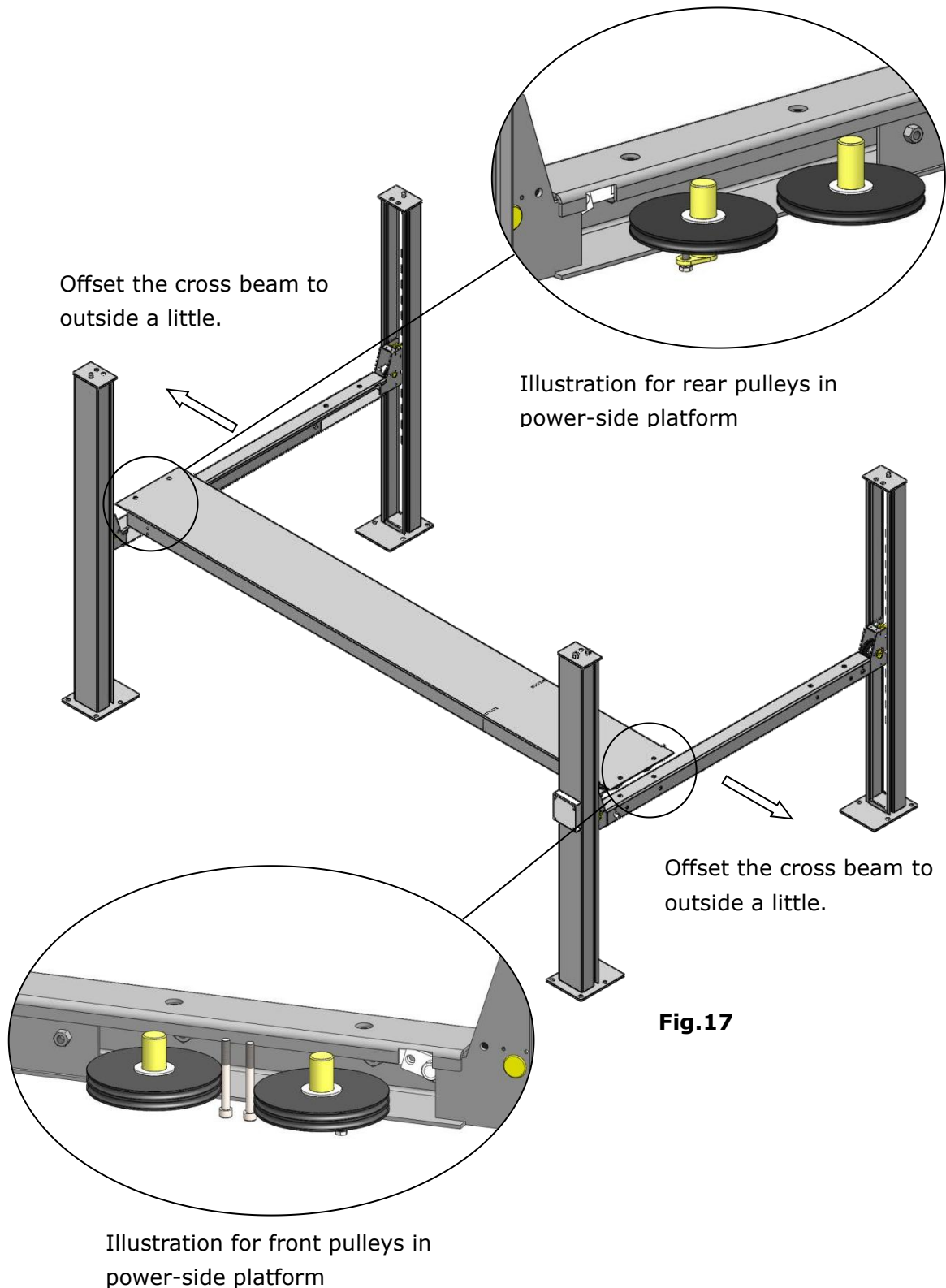

Fig. 16

F. Install power side platform.

1. Install the power-side platform on the cross beams by a fork lift or manual, offset the cross beams to outside a little until the pulleys of both platforms enter into the cross beams opening (**See Fig.17**). Aligning holes on the power-side platform and cross beam, then screw up the bolts.



2. **Install tire stop plate with bolts and washer on the platform:** Tighten the platform on cross beam **B** with bolts, tighten the tire stop plate on cross beam **A** with bolts

Note: The bolts for the side with tire stop plate is longer, pay attention when choosing the bolts (**See Fig.18**)

Instruction: 1). This lift is designed in both side (cross beam **A** and cross beam **B**) car in direction, user can install the lift according to the location. Below is the installation for the side of cross beam **B** car in direction. If choosing the side of cross beam **A** car in direction, then install the tire stop plate to the other side.

2). Power-side column can be installed at any position on customers' requirement, but the power unit must be installed near the side with the safety lock release handle.

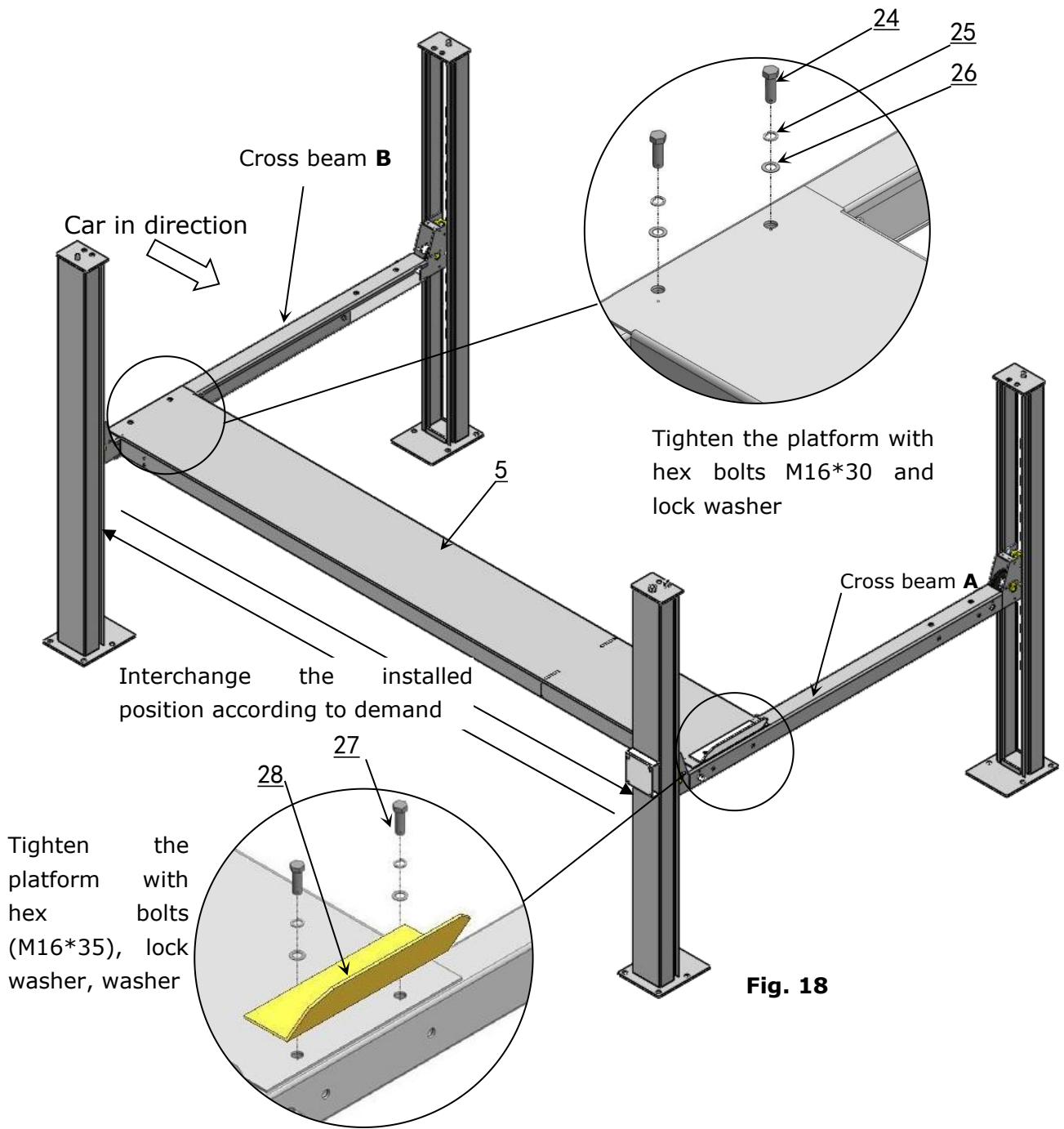
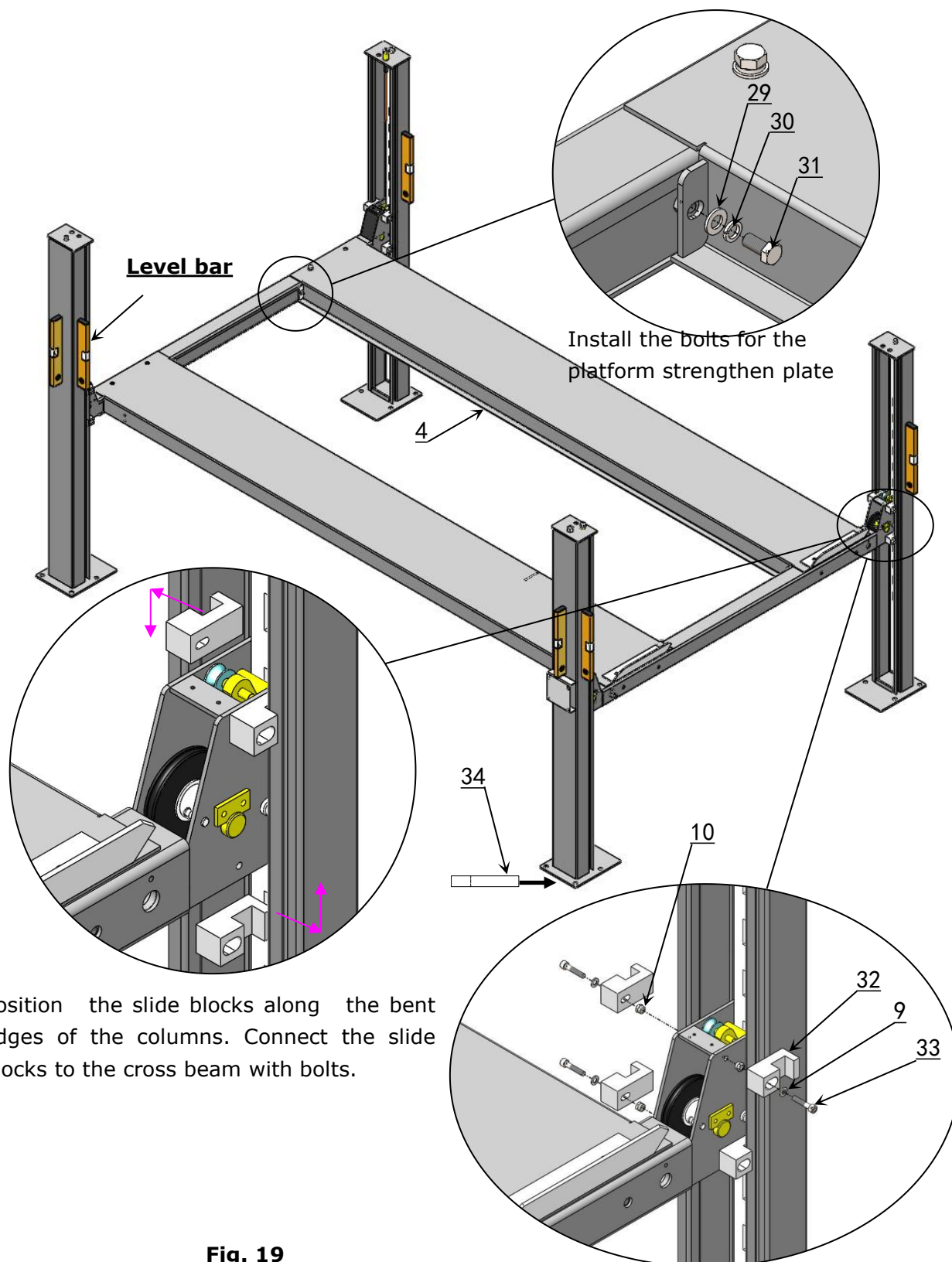

Fig. 18

G. Install offside platform and plastic block, then install the bolts for the platform strengthen plate, check the plumbness of columns with level and adjusting with the shims (See Fig. 19)



Position the slide blocks along the bent edges of the columns. Connect the slide blocks to the cross beam with bolts.

Fig. 19

Note: DO NOT completely tighten the limit slide blocks. Loosen 1/4 lap after tightening.

H. Illustration for cable installation

1. Pass through the cables from the platform to the columns according to the number of the cables (**See Fig. 20**)

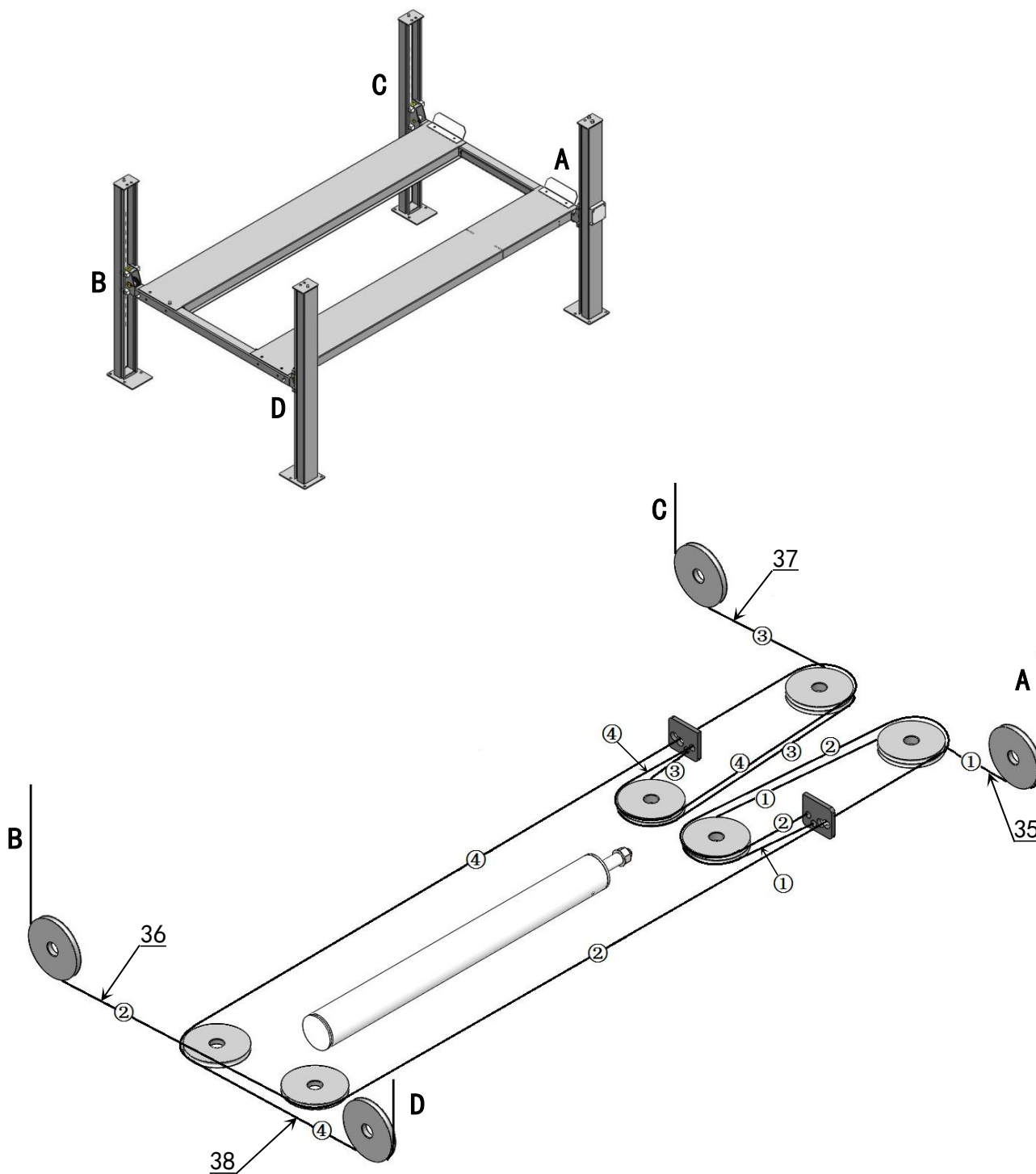

Cable installation diagram

Fig. 20

NO.	①	②	③	④
Cable				
Length (inc. connecting fitting)	4264mm	9529mm	5684mm	8112mm

2. The cable goes through the cross beam to top plate of columns and be screwed with cable nuts (**See Fig. 21**).

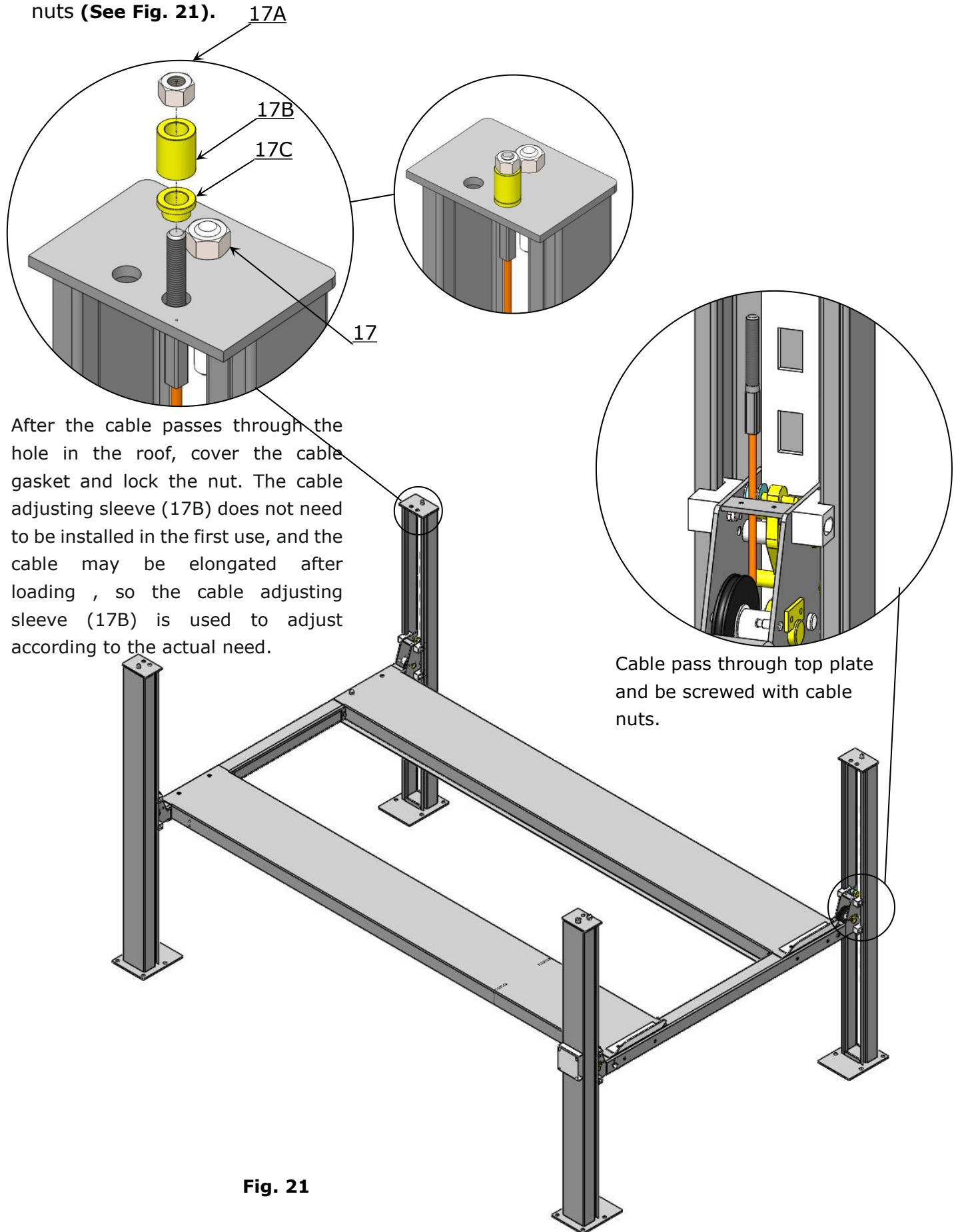

After the cable passes through the hole in the roof, cover the cable gasket and lock the nut. The cable adjusting sleeve (17B) does not need to be installed in the first use, and the cable may be elongated after loading , so the cable adjusting sleeve (17B) is used to adjust according to the actual need.

Cable pass through top plate and be screwed with cable nuts.

Fig. 21

3. Illustration for platform cables (See Fig. 22).

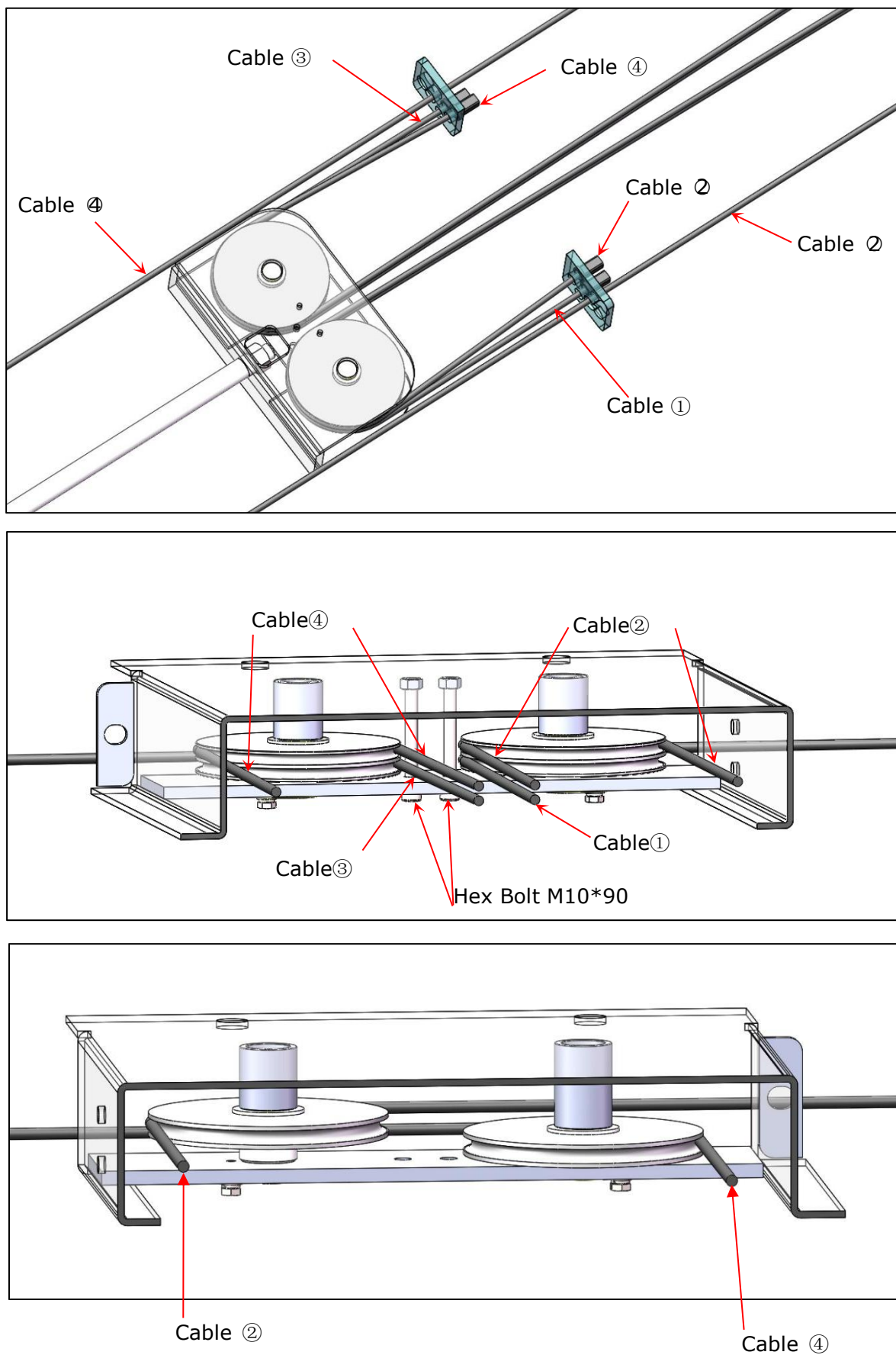

Fig. 22

I. Install release handle assy. See Fig.23

Noted: Power unit must be installed near the safety release handle.

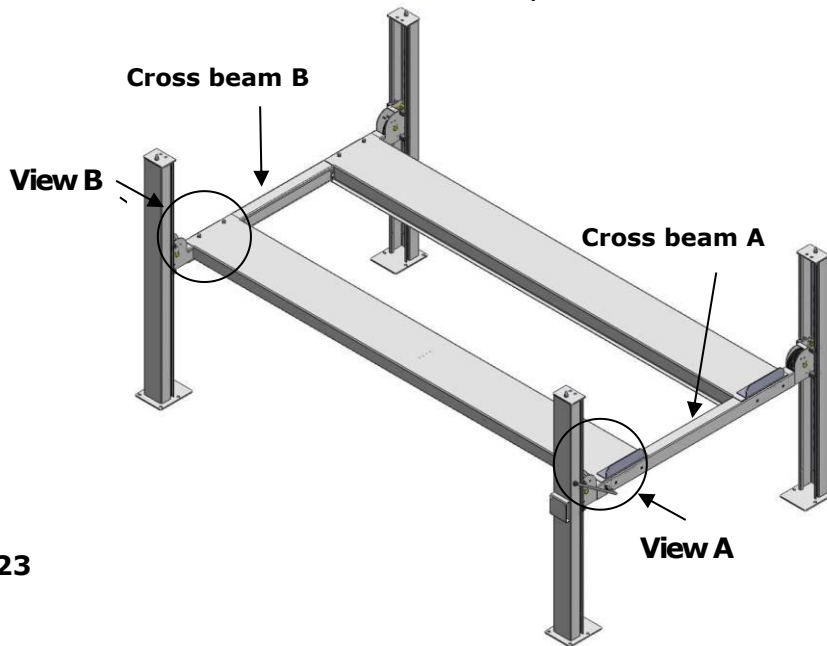
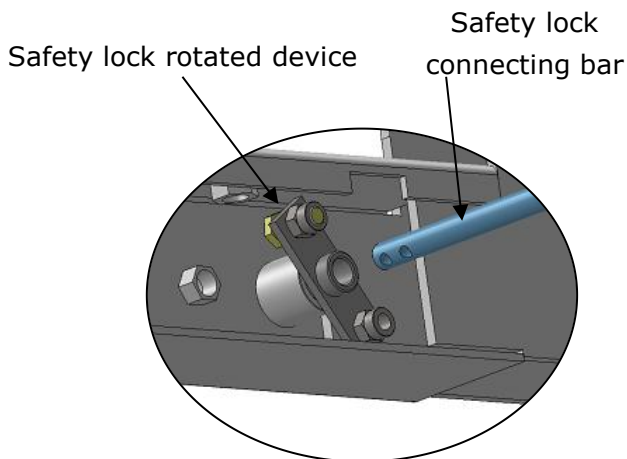
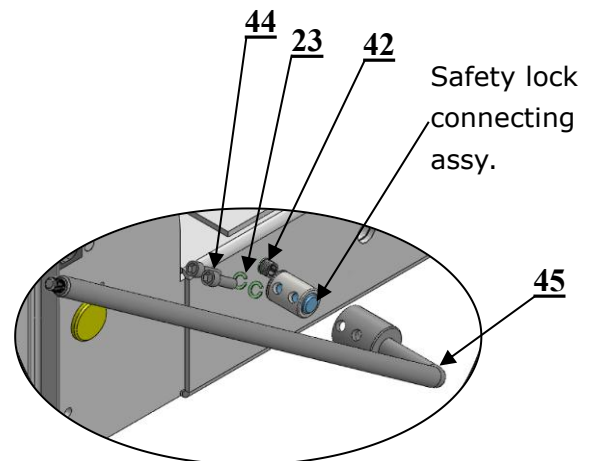

Fig. 23



Pass through the connecting bar from the safety lock rotated device of cross beam **A/B**



View A

According to the above diagram, fix lock release handle and the safety lock connecting with M8*35 bolts and washers on cross beam **A**.

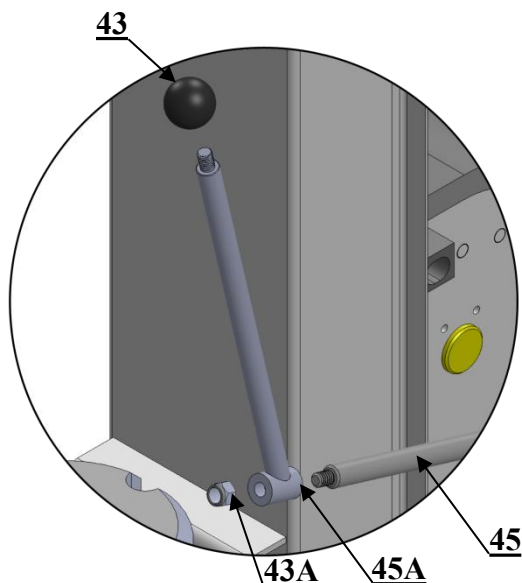

Install extend lock release handle and plastic ball

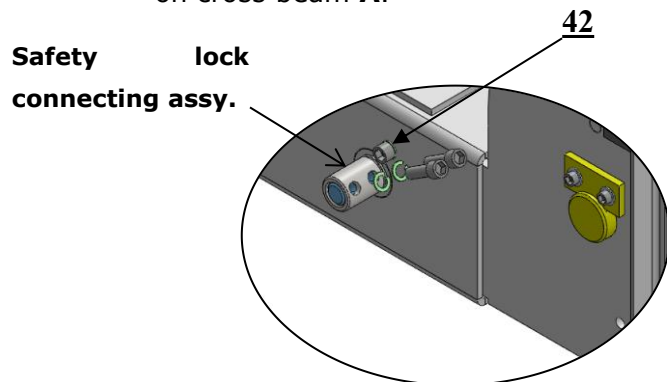

View B

According to the above diagram, fix safety lock connecting bar and safety lock connecting by M8*35 bolts and washers on cross beam **B**.

J. Install power unit and connecting tube (See Fig. 24).

Noted: Power unit must be installed near the safety release handle.

1. Install Power unit on the cross beam **A**

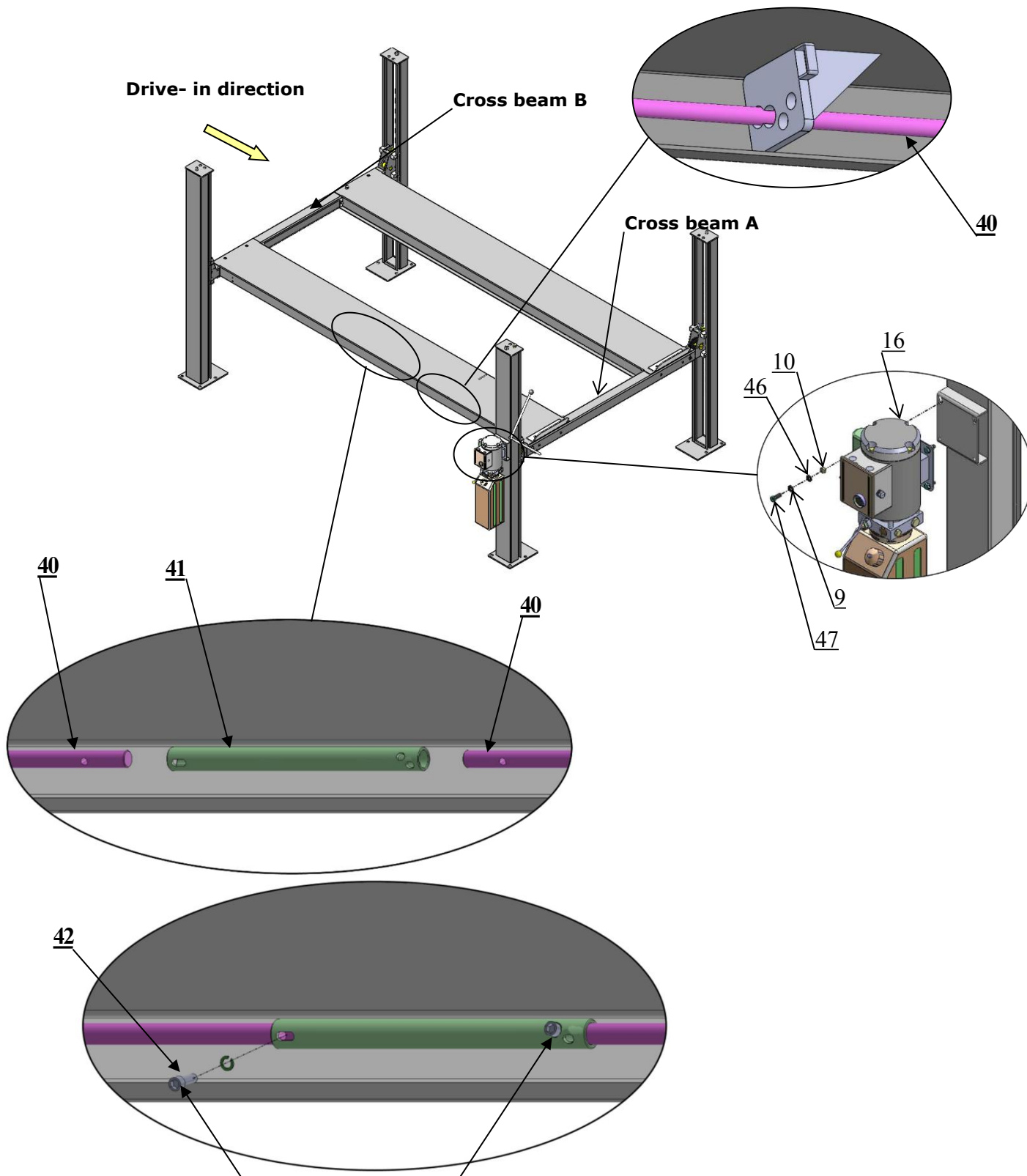

Fix the connecting tube and the connecting bar for safety device by M8*25 socket bolts (Connecting tube pass through the fixing plate)

Fig. 24

2. Install Power unit on the cross beam **B** (See Fig. 25).

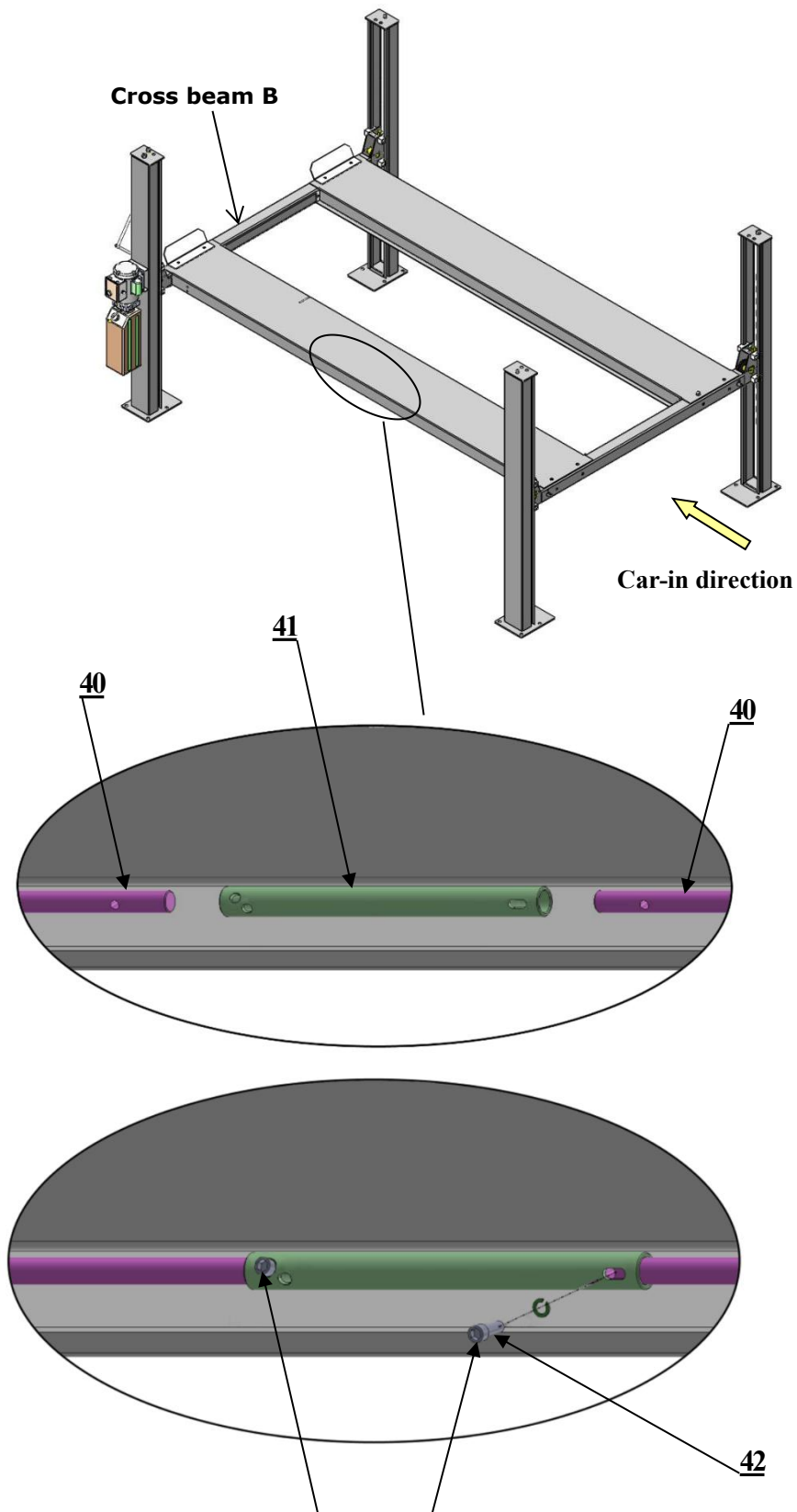

**Fix the connecting tube and the connecting bar for safety device by M8*25 socket bolts
(Connecting tube pass through the fixing plate)**

Fig. 25

K. Install Hydraulic System

1. For power unit attached to the column of cross beam **A** (See Fig. 26)

Note: Oil hoses connected to oil cylinder must be passed above the cable to avoid the oil hose scratched by cable.

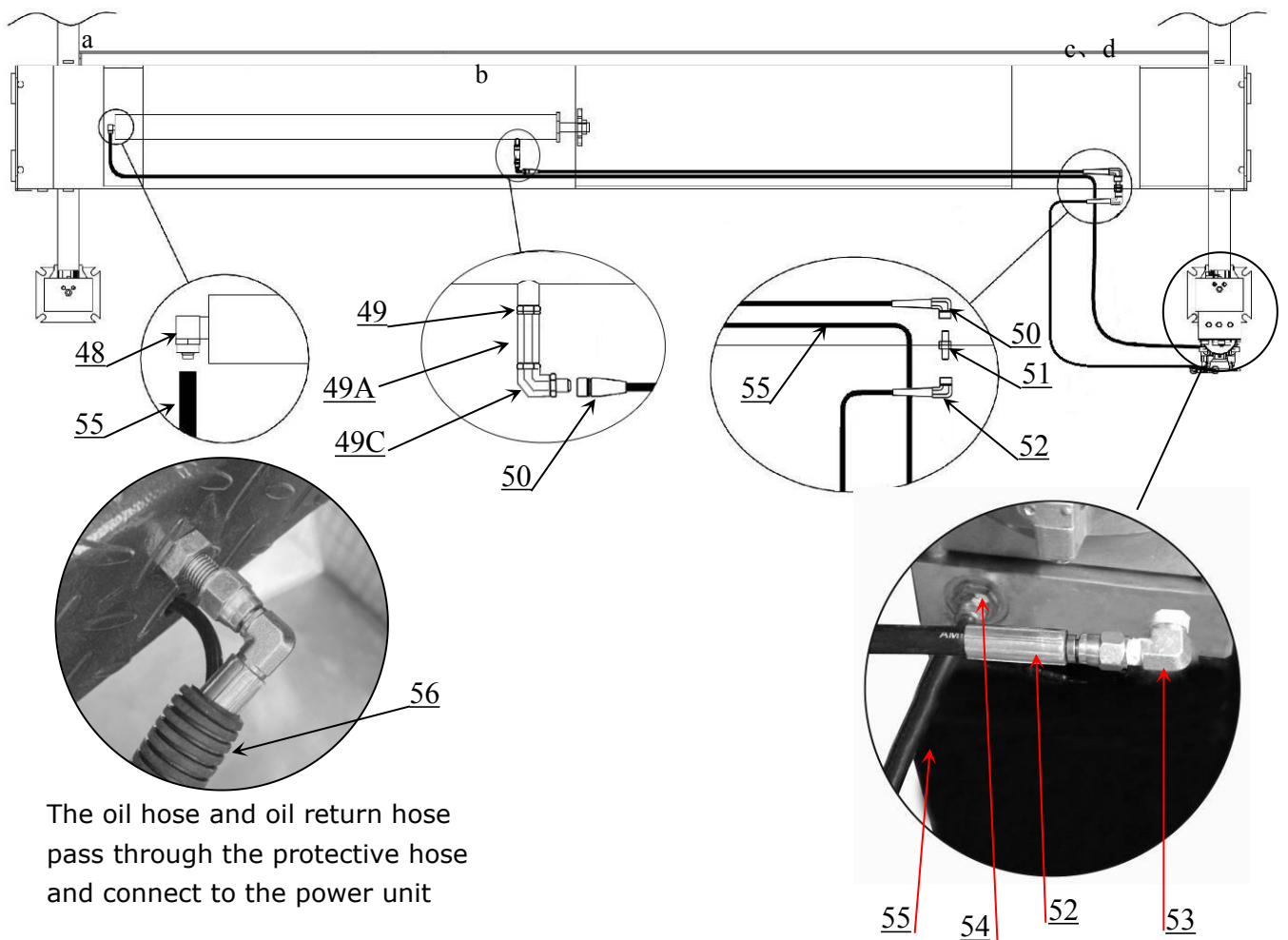
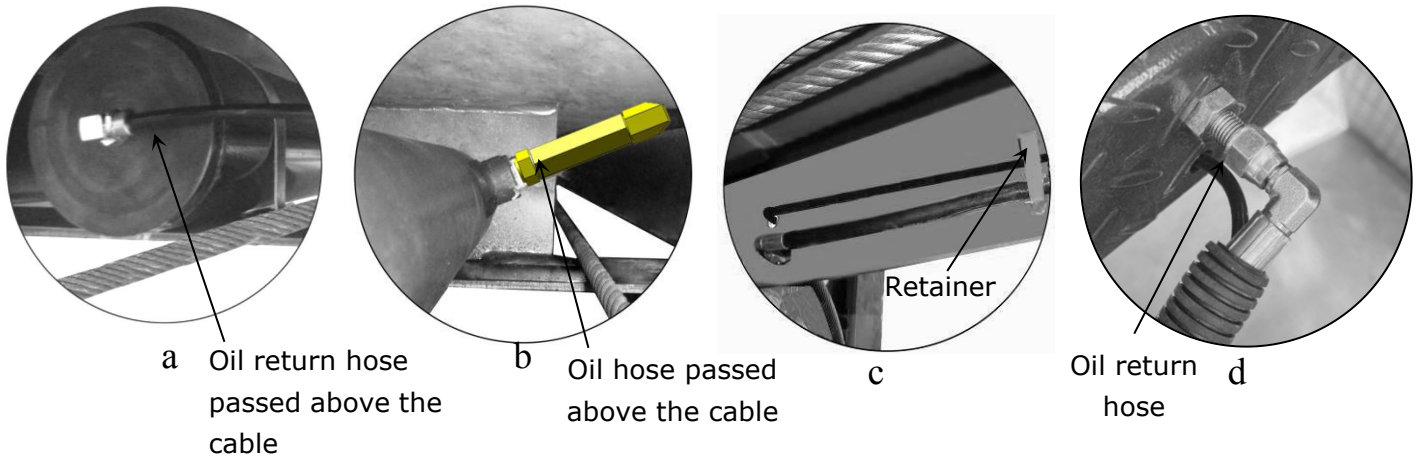

Fig. 26

2. For power unit attached to the column of cross beam **B** (See Fig. 27).

Note: The oil return hose can be adjusted when installation.

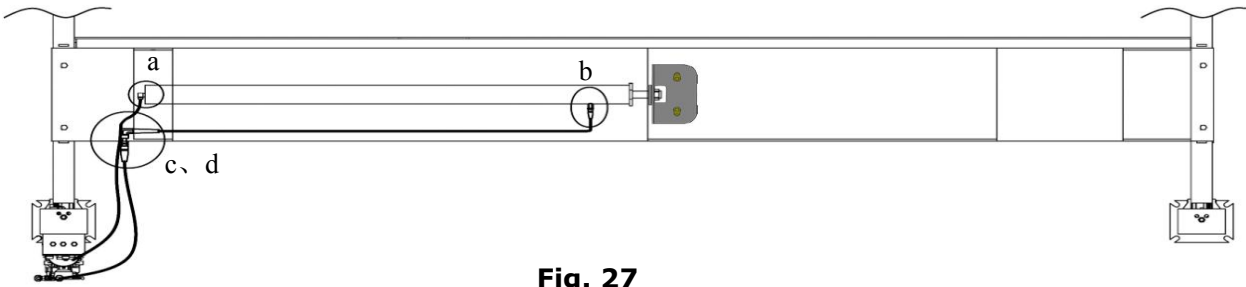

Fig. 27

L. Install Electrical System

Connect the power source on the data plate of Power Unit.

Note: For the safety of operators, the power wiring must contact the floor well.

Single phase motor (See Fig. 28).

1. Connecting the two power supply lines (active wire **L** and neutral wire **N**) to terminals of AC contactor marked **L1, L3** respectively.
2. Connecting the two motor wires to terminals of AC contactor marked **T1, T3**.
3. Connecting **A2** to **L3** of AC contactor.
4. Connecting the two wire of the button switch to the terminals of AC contactor marked **A2,**

L1.

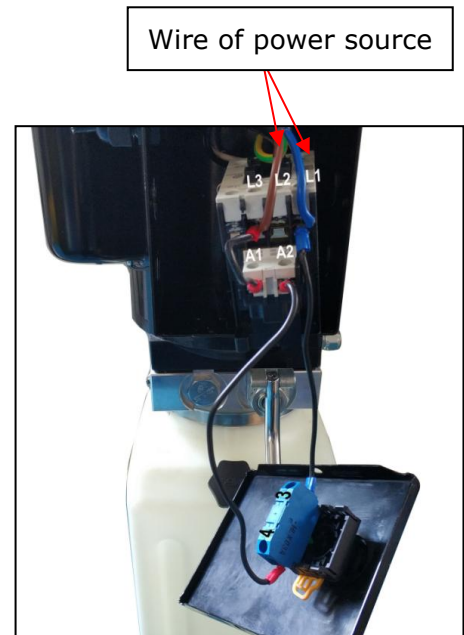
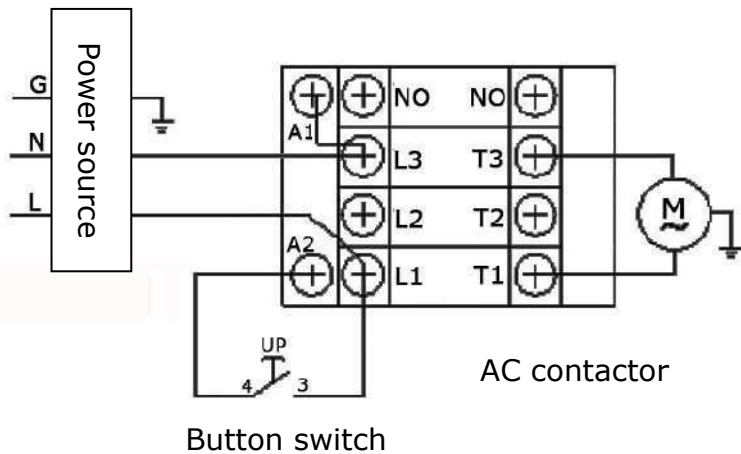

Fig. 28

M. Install spring and safety cover of cross beam (See Fig. 29).

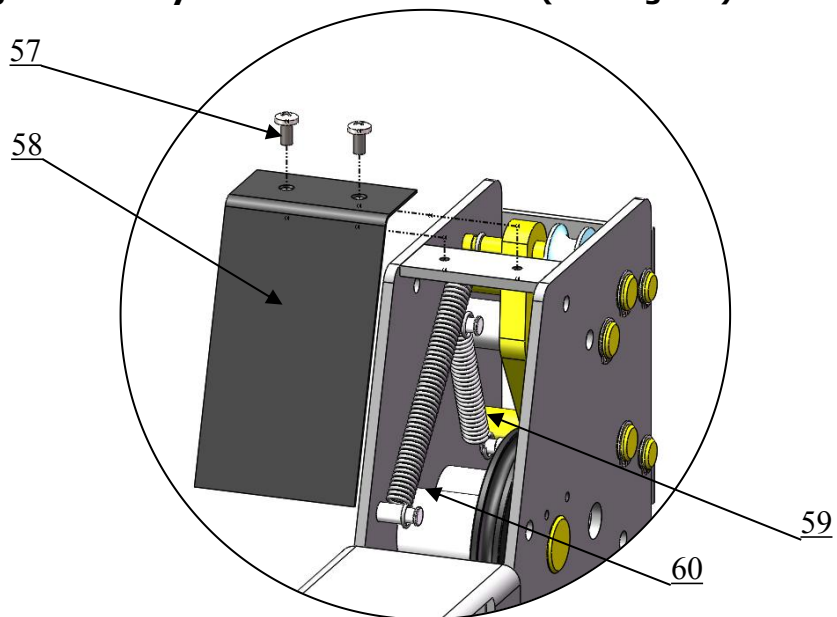

Fig. 29

N. Install drive-in ramp, optional jack tray and optional plastic oil pans (See Fig. 30).

According to the below diagram screw up the M16*30 bolts, then attach the drive-in ramp.

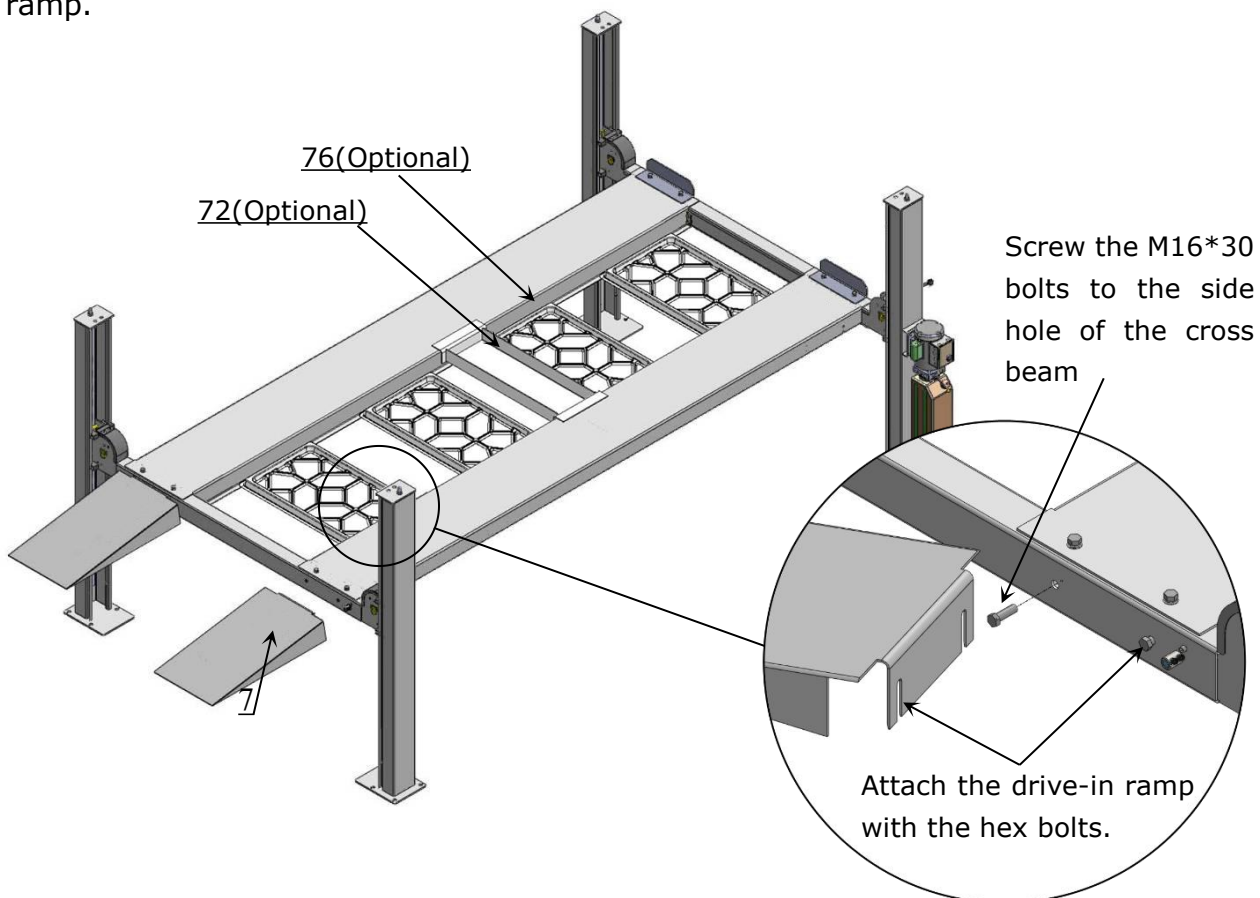

Fig. 30

O. Install Rear wheel stop plates (See Fig. 31)

After driving the vehicle on the lift, take off the drive-in ramp, install rear wheel stop plates to the drive-in ramp position.

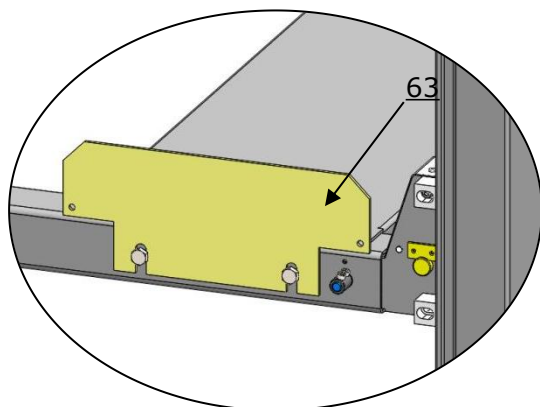

Fig. 31

P. For optional kits installation.

1. Install optional caster kits (See Fig. 32)

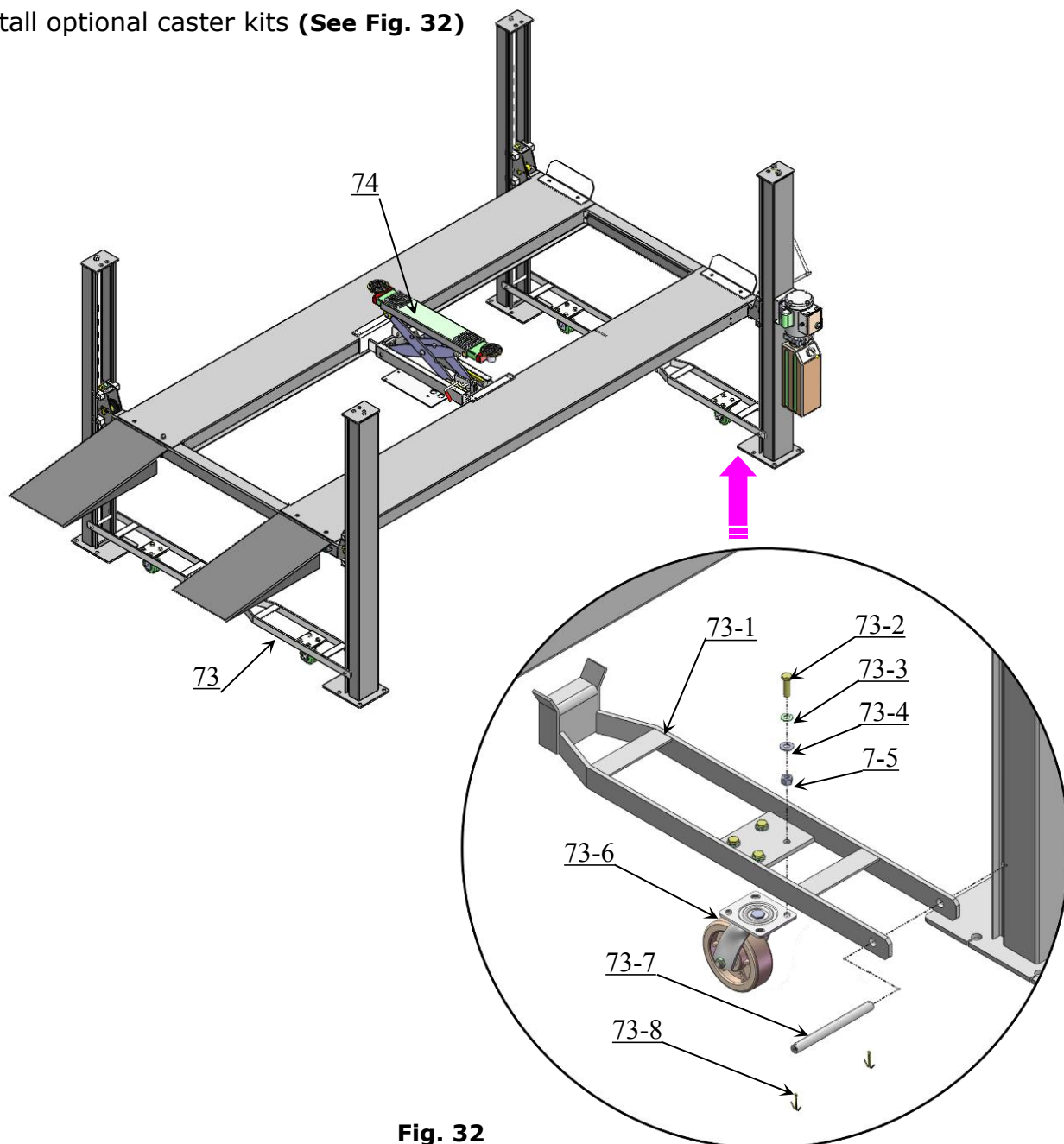
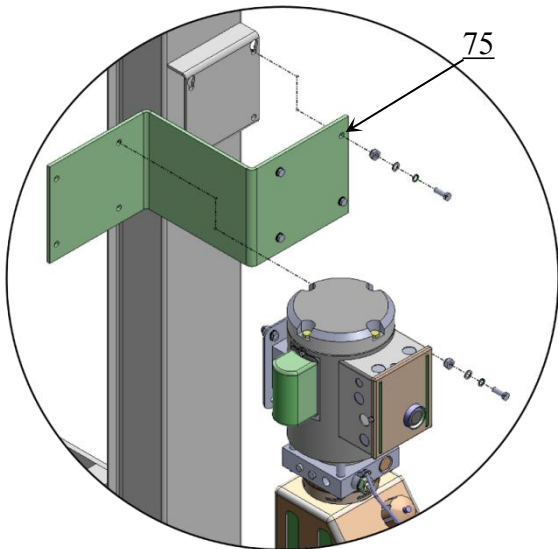

Fig. 32

Item	Part#	Description	QTY.	Note
73-1	11410042A	Support bracket	4	
73-2	10209125	Hex bolt	16	
73-3	10209039	Lock washer $\phi 10$	16	
73-4	10209022	Washer $\phi 10$	16	
73-5	10209021	Hex nut M10	16	
73-6	10410035	Plastic wheel	4	
73-7	11410034	Connecting pin $\phi 19 \times 216$	4	
73-8	10209012	Hair Pin $\phi 3.2$	8	

2. Install optional motor fixing bracket (See Fig. 33, Fig.34).



Motor fixing bracket on cross beam **A**

Fig. 33

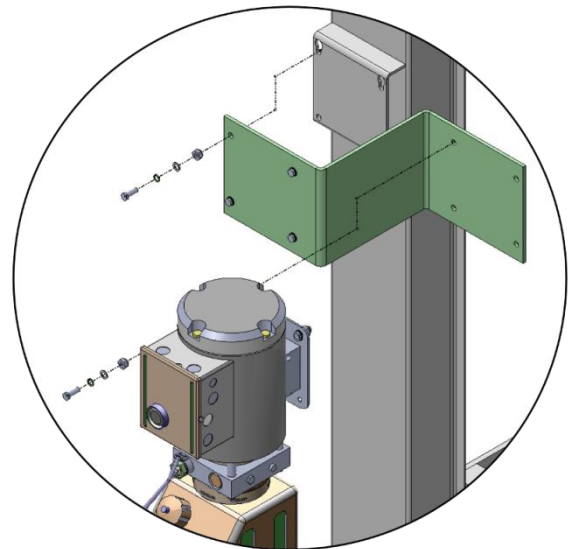

Motor fixing bracket on cross beam **B**

Fig. 34

P. Fix the anchor bolts

1.1 Prepare the anchor bolts (See Fig. 35).

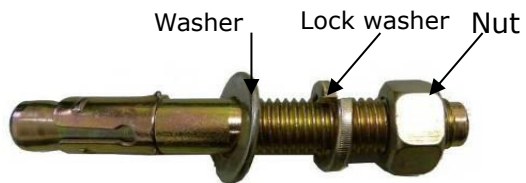

Fig. 35

1.2 Using the prescribed rotary hammer drill, and drill all the anchor holes and install the anchor bolts. Do not tighten the anchor bolts (**See Fig. 36**).

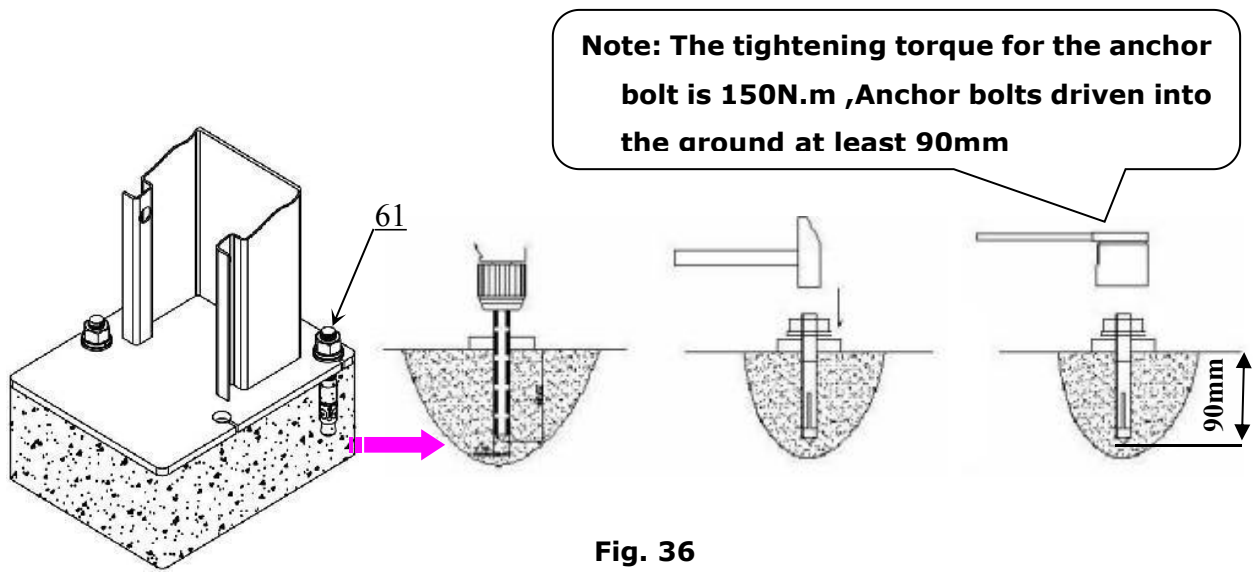

Fig. 36

IV. EXPLODED VIEW

Model CL3000-4P

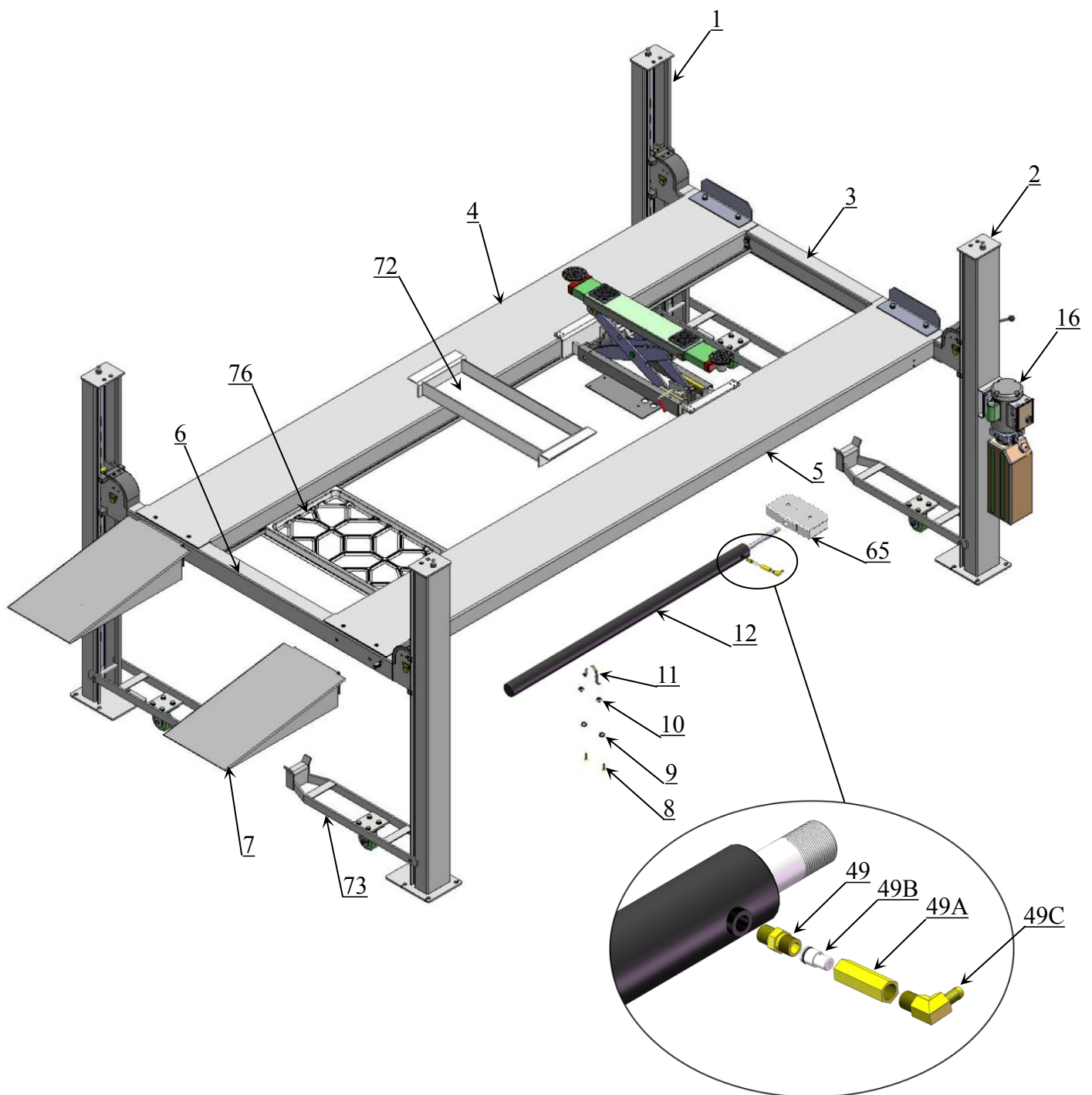

Fig. 37

Power-side platform

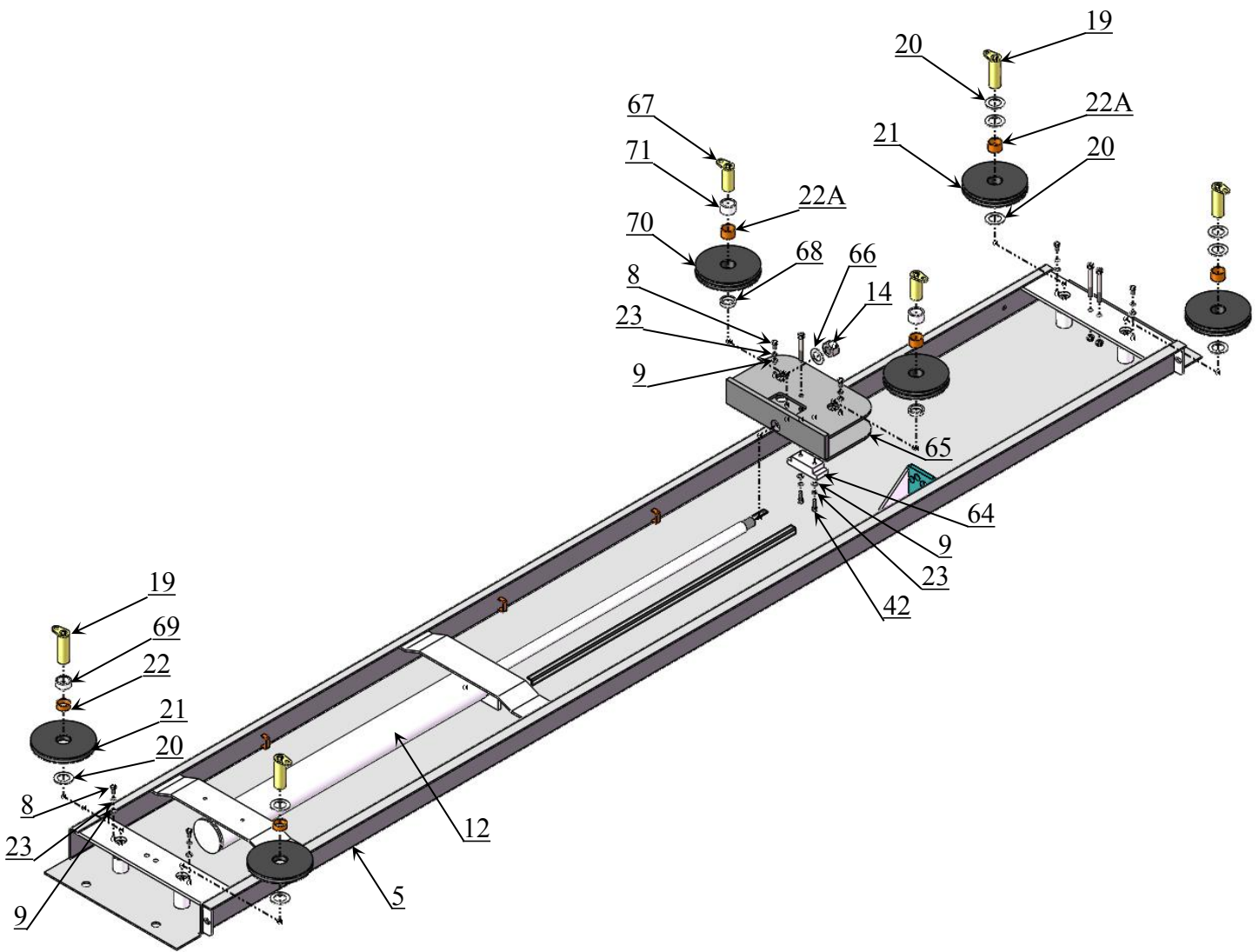

Fig. 38

PARTS LIST FOR MODEL CL3000-4P

Item	Part#	Description	QTY.	Note
1	11410002	Power-side Column	3	
2	11410001	Offside Column	1	
3	1104542001B	Cross Beam A	1	
4	1104543001B	Offside Platform	1	
5	1104543001A	Power-side Platform	1	
6	1104542001B	Cross Beam B	1	
7	1104543010	Drive-in ramp	2	
8	10201002	Hex Bolt M8*16	6	
9	10209033	Washer φ8	36	
10	10209005	Self locking Nut M8	26	
11	11423004	Cylinder fixed ring	1	

Item	Part#	Description	QTY.	Note
12	1004546000	Cylinder φ80*876	1	
13	1104533013A-01	Piston rod connecting seat	1	
14	10410012	Hex Nut M24	1	
15	10201005	Split Pin φ4*50	1	
16	81513006	Manual Power Unit	1	
17	10420175A	Hex nut M20	8	
17A	10209066	Hex nut M16	8	
17B	1104541002	Adjusting sleeve of cable	4	
17C	1104541001	Cable gasket	4	
18	11410022	Safety ladder L=1974	4	
19	1104543009A	Pulley pin φ30*86.5	4	
20	10481005	Washer φ30	21	
21	1104543011	Pulley φ167*16	2	
22	1004542002	Bronze bush for pulley φ36*φ30.1*15	6	
22A	10620141	Bronze bush φ36*φ30.1*24	4	
23	10209034	Lock Washer φ8	16	
24	10410013	Hex Bolt M16*30	8	
25	10420137	Lock washer φ16	8	
26	10420029	Washer φ16	8	
27	10410014	Hex Bolt M16*35	4	
28	11410116-1	Tire stop plate	2	
29	10206006	Washer φ12	8	
30	10420026	Lock washer φ12	4	
31	10410105	Hex Bolt M12*20	4	
32	10410016A	Plastic block 81*38*38mm	16	
33	10410017	Socket bolt M8*40	16	
34	10201090	Shim(1mm)	20	
	10620065	Shim(2mm)	20	
35	1004543003	Cable ①	1	
36	1004543004	Cable ②	1	
37	1004543002	Cable ③	1	
38	1004543001	Cable ④	1	
39	85090099	Socket Bolt M10*90	2	
39A	85090332	Socket Bolt M10*70	1	
40	1104542009	Connecting bar for safety device φ19*1791mm	2	
41	11410024	Connecting tube	1	
42	10209032	Socket bolt M8*25	6	
43	10217005	Plastic ball M10	1	
43A	10209056	Self locking Nut M10	1	
44	10410025	Socket bolt M8*35	4	
45	11410026	Safety release handle	1	
45A	11410100	Extension lock release handle	1	

Item	Part#	Description	QTY.	Note
46	10209004	Rubber ring $\phi 8 * \phi 20 * 3$	4	
47	10209003	Hex Bolt M8*25	8	
48	10420166	90° Fitting	1	
49	11420243	Straight Fitting for cylinder	1	
49A	11420245	Limit block	1	
49C	11209119	Compensation Valve	1	
49C	10201020	90°degree fitting	1	
50	1004543005	Oil hose	1	
51	10420120	Extend straight fitting with nut	1	
52	1004543008	Oil hose	1	
53	10209060	90° Fitting for power unit	1	
54	10420095	Straight fitting	1	
55	1004543007	Oil return hose L=4962mm	1	
56	10410036	Protective hose $\phi 20 * 1 * 1500 \text{mm}$	1	
57	10209145A	Cup head bolt with washer M6*12	8	
58	1104542012	Plastic cover for cross beam	4	
59	1004542001	Spring $\phi 14 * 2.0 * 50$	4	
60	10420033	Spring $\phi 14 * 1.8 * 100$	4	
61	10209059	Anchor bolt 3/4*5-1/2	16	
62		Parts box	1	
63	11410094	Tire stop plate	2	
64	1004543006	Slider block 106*40*29	1	
65	1104533013A-01	Piston rod connecting seat	1	
66	10640109	Washer $\phi 25.5 * 44 * 2$	1	
67	1104533017A-01	Pulley Pin $\phi 25 * 77.5$	2	
68	1104543019	Adjusting sleeve of pulley $\phi 40 * 4.75 * 9$	2	
69	1104543016	Adjusting sleeve of pulley $\phi 40 * 4.75 * 18$	1	
70	1104543017	Pulley $\phi 167 * 25$	4	
71	1104533024	Pad tube $\phi 40 * 4.75 * 23$	2	
Optional kits				
72	11410040	Jack tray	1	
73	1040801	Caster kits	4	
74	96600002	Sliding jack	1	
75	1140802B	Motor fixing bracket	1	
76	10410039	Plastic oil tray	4	

4.1 CYLINDERS (1004536000)

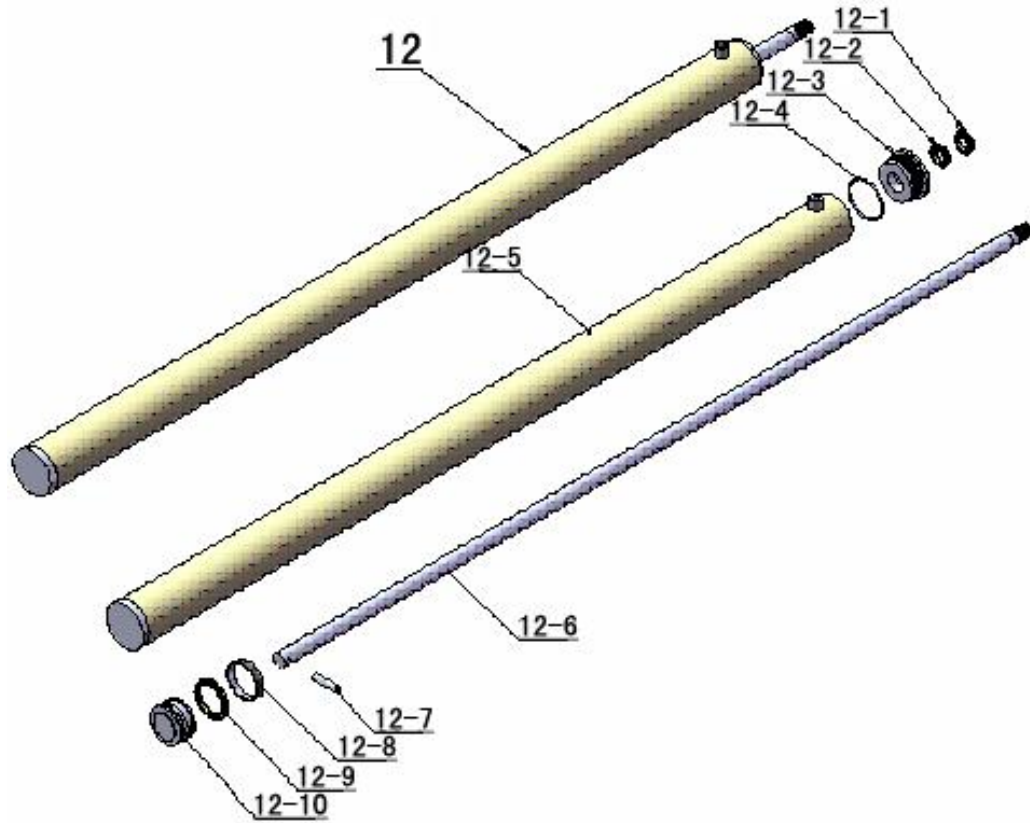

Fig. 39

Parts For Cylinder

Item	Part#	Description	QTY.	Note
12-1	10420059	Dust ring $\Phi 30 * \Phi 38 * (5 \sim 6.5)$	1	
12-2	10420060	Y- Ring IDI $\Phi 30 * \Phi 40 * 8$	1	
12-3	11420061	End cover	1	
12-4	10420062	O- Ring $\Phi 81.5 * 3.55$	1	
12-5	1004546001A	Cylinder components	1	
12-6	1104546002	Piston Rod	2	
12-7	11420065	Cylindrical pin	1	
12-8	10420066	Support Ring $\Phi 74 * \Phi 80 * 15 * 3$	1	
12-9	10420067	Y- Ring OSI $\Phi 70 * \Phi 80 * 6$	1	
12-10	11420068	Piston	1	

4.2 CROSS BEAM (10410003/10410006)

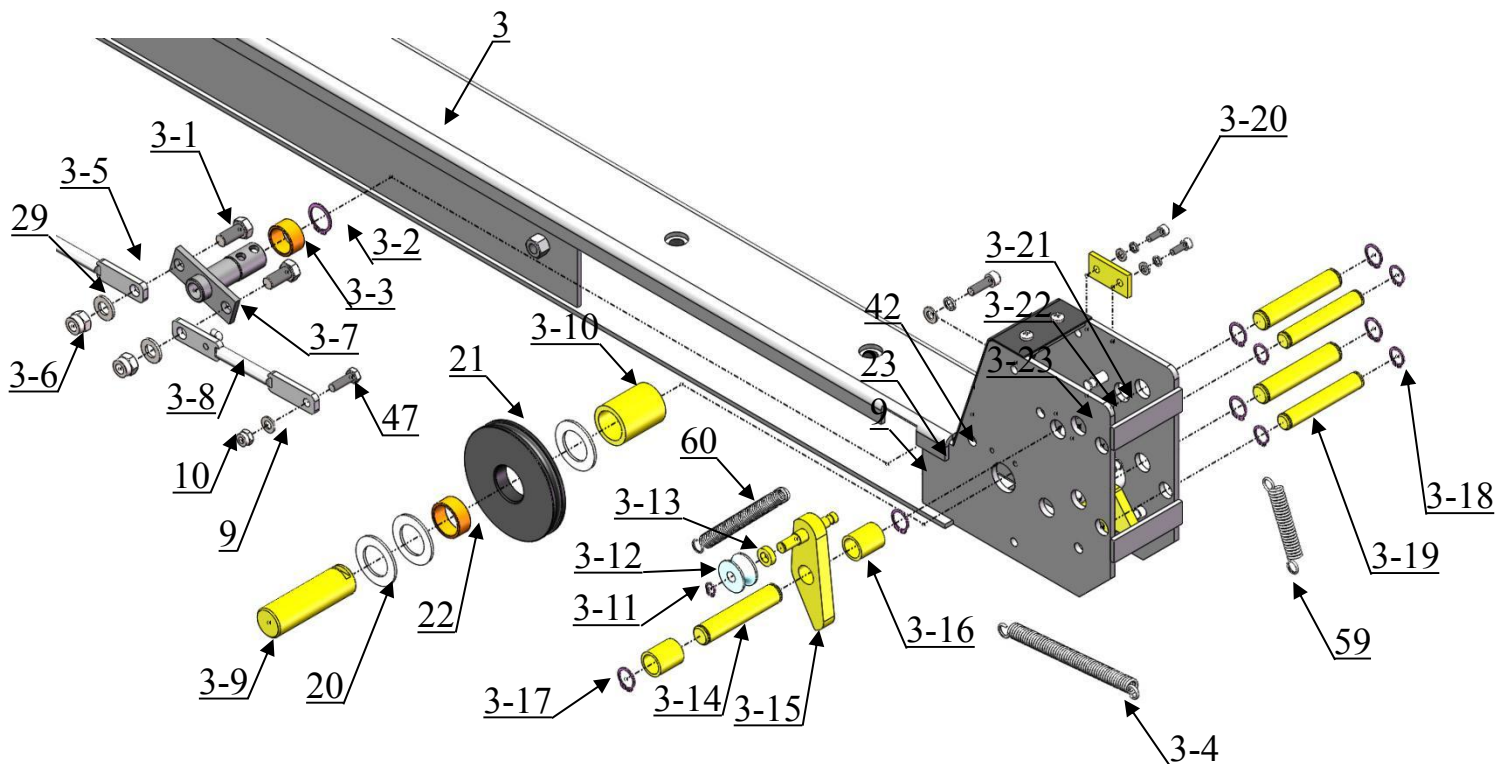

Fig.40

Parts For cross beam

Item	Part#	Description	QTY.	Note
3-1	10206024	Hex Bolt M12*25	4	
3-2	10206032	Snap Ring $\phi 25$	2	
3-3	10217020	Bronze Bush $\phi 31 * \phi 25.1 * 16$	2	
3-4	10410099	Spring $\phi 14 * \phi 2.5 * 100$	2	
3-5	1104542008	Connecting bar for safety lock	2	
3-6	10206023	Self locking Nut	4	
3-7	1104542005A	Safety lock rotated device assy.	2	
3-8	1104542011A	Connecting bar assy. for safety lock	2	
3-8	1104542011A	Pulley Pin	4	
3-9	1104542006-01	Pulley Bush	10	
3-10	1104542007	Pulley pin sleeve	4	
3-11	10209010	Snap ring	4	
3-12	10420035	Tension pulley	4	
3-13	11420174	Spacer	4	
3-14	11420171	Pin	12	
3-15	11420175	Slack-cable safety lock (Left & Right)	2 each	
3-16	11420172	Pin Bush For Slack-cable safety lock	8	
3-17	10206019	Snap ring $\phi 19$	24	
3-18	10420037	Snap ring $\phi 16$	16	
3-19	11420038	Pin $\phi 16 * 98$	8	
3-20	10420138	Socket Bolt M6*16	8	
3-21	10209149	Lock washer $\phi 6$	8	
3-22	10420045	Washer $\phi 6$	8	
3-23	11420044	Stop block	4	

4.3 Manual Power Unit (81513006)
220V/50HZ/Single Phase

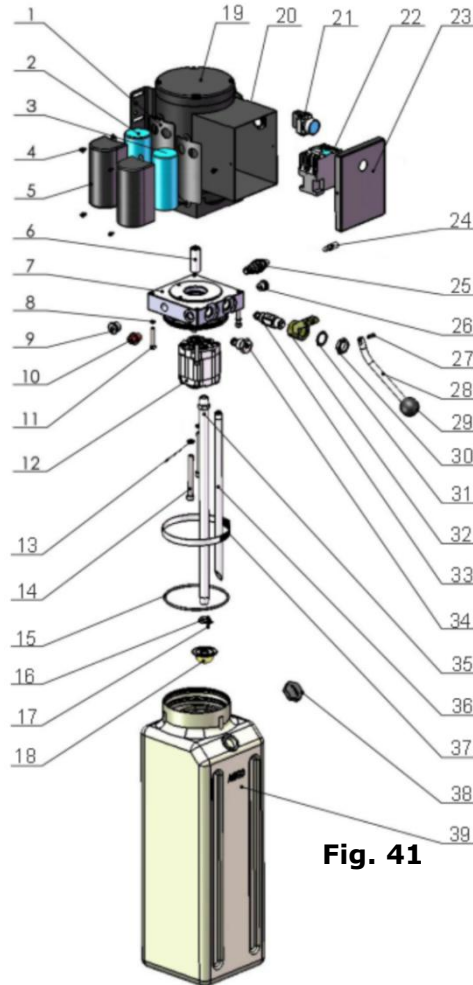

Fig. 41

Item	Part#	Description	QTY.	Note
1	81400180	Rubber Pad	2	
2	81400250	Start Capacitor	1	
3	81400200	Run Capacitor	1	
4	1061K052	Cup Head bolt with washer	6	
5	81400527	Capacitor cover	2	
6	81400363	Motor Connecting Shaft	1	
7	80101013	Manifold Block	1	
8	10209149	Lock washer	4	
9	81400276	Iron Plug	1	
10	81400259	Rubber Plug	1	
11	85090142	Socket Bolt	4	
12	81400280	Gear Pump	1	
13	10209034	Lock Washer	2	
14	81400295	Socket Bolt	2	
15	81400365	O Ring	1	
16	10209152	Tie	1	
17	85090167	Magnet	1	
18	81400290	Filter	1	
19	81400413	Motor	1	

20	80101036	Button	1	
21	10420070	Ac Contactor	1	
22	41030055	Terminal Box Cover	1	
23	80101037	Sticker	1	
24	81400560	Throttle valve	1	
25	81400266	Relief Valve	1	
26	81400284	Iron Plug	1	
27	81400452	Pin	1	
28	81400451	Release Valve Handle	1	
29	10209020	Plastic Ball	1	
30	81400421	Release Valve Nut	1	
31	81400422	Self Lock washer	1	
32	81400449	Valve Seat	1	
33	81400567	Release Valve	1	
34	80203001	Check Valve	1	
35	81400375	Oil suction hose	1	
36	81400376	Oil return hose	1	
37	81400364	clamp	1	
38	81400263	Oil tank cover	1	
39	81400320	Oil tank	1	

Illustration of hydraulic valve for hydraulic power unit

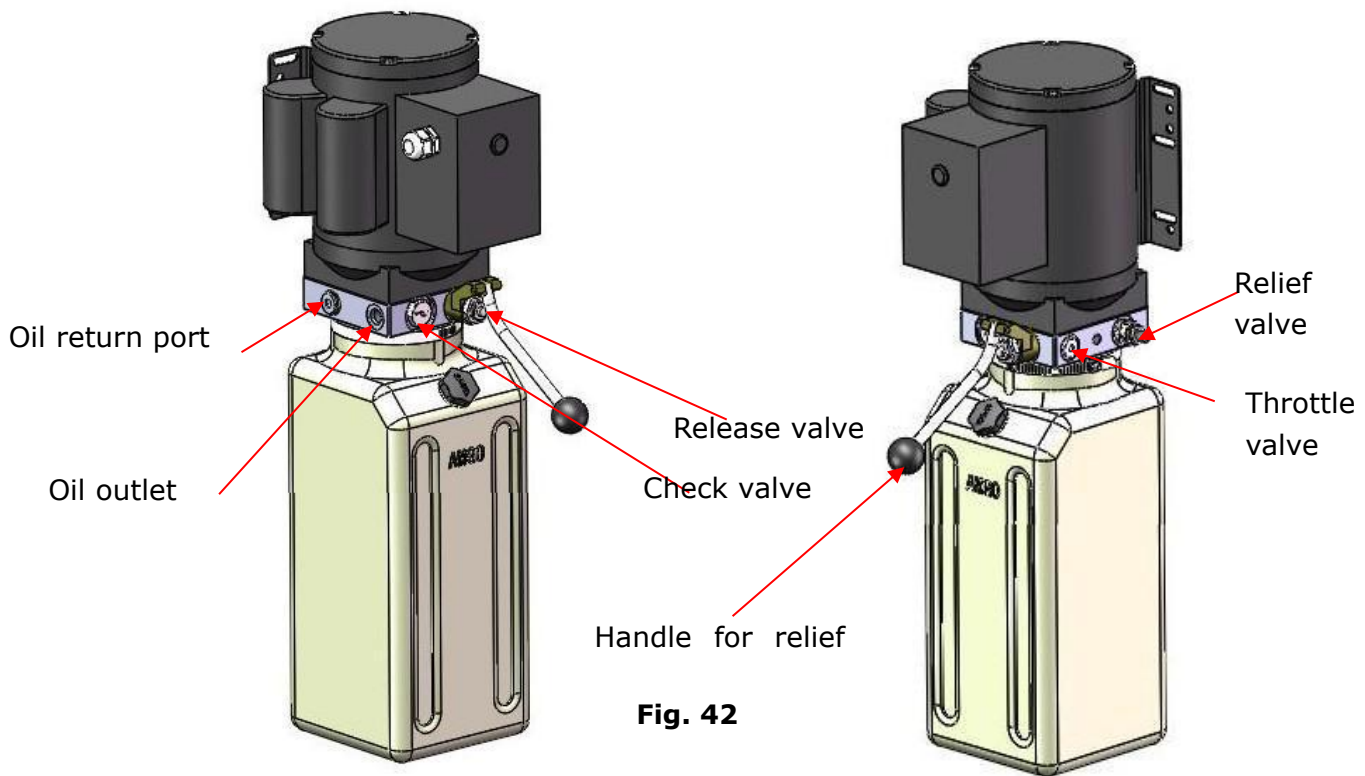

Fig. 42

VI. OPERATION INSTRUCTIONS

To lift vehicle

1. Keep clean of environment near the lift.
2. Drive vehicle to the platform and put on the brake.
3. Take off the drive-in ramp, install rear wheel stop plates to the drive-in ramp position.
4. Turn on the power and press the control button, raise the lift to the working position.

Note: make sure the vehicle is steady when the lift is raised.

5. Press the release valve handle to lock the lift in the safety position. Make sure the safety device is locked at the same height.

To lower vehicle

1. Be sure the clearance of around and under the lift, only leaving operator in lift area.
2. Press the control button, the lift will be raised for 3-5 seconds, and then press the safety release handle, make sure the safety device released, press the release valve handle by the other hand, then the lift starts being lowered automatically.
3. Drive away the vehicle when the lift is lowered to the lowest position. Take off the rear wheel stop plates and install drive-in ramp, then left the lift.
4. Turn off the power.

VII. MAINTENANCE SCHEDULE

Monthly:

1. Lubricate cable with lubricant;
2. Check all cable connection, bolts and pins to insure proper mounting;
3. Make a visual inspection of all hydraulic hoses/lines for possible wear or leakage;
4. Lubricate all rollers, safety devices with 90wt. gear oil or equivalent.

Every six months:

1. Make a visual inspection of all moving parts for possible wear, interference or damage.
2. Check and adjust as necessary, equalizer tension to insure level lifting.
3. Check columns for plumbness.

Oil cylinder maintenance:

In order to extend the service life of the oil cylinder, please operate according to the following requirements.

1. Recommend to use N46 anti-wear hydraulic oil.
2. The hydraulic oil of the lifts should be replaced regularly during using. Replace the hydraulic oil 3 months after the first installation, Replace the hydraulic oil once a year afterwards.
3. Make at least one full trip raising and lowering per day. For exhausting the air from the system, which could effectively avoid the corrosion of the cylinder and damage to the seals caused by presence of air or water in the system.
4. Protect the outer surface of the oil cylinder's piston rod from bumping and scratching, and timely clean up the debris on the oil cylinder dust-ring and the piston rod.

VIII. TROUBLE SHOOTING

TROUBLE	CAUSE	REMEDY
Motor does not run	<ol style="list-style-type: none"> 1. Button does not work 2. Wiring connections are not in good condition 3. Motor burned out 4. AC contactor burned out 	<ol style="list-style-type: none"> 1. Replace button 2. Repair all wiring connections 3. Repair or replace motor 4. Replace AC contactor
Motor runs but the lift is not raised	<ol style="list-style-type: none"> 1. Motor runs in reverse rotation 2. Release valve in damage 3. Gear pump in damage 4. Relief valve or check valve in damage 5. Low oil level 	<ol style="list-style-type: none"> 1. Reverse two power wire 2. Repair or replace 3. Repair or replace 4. Repair or replace 5. Fill tank
Lift does not stay up	<ol style="list-style-type: none"> 1. Release valve out of work 2. Relief valve or check valve leakage. 3. Cylinder or fittings leaks 	Repair or replace
Lift raises too slow	<ol style="list-style-type: none"> 1. Oil line is jammed 2. Motor running on low voltage 3. Oil mixed with Air 4. Pump leaks 5. Overload lifting 	<ol style="list-style-type: none"> 1. Clean the oil line 2. Check electrical system 3. Fill tank 4. Repair or replace pump 5. Check load
Lift cannot lower	<ol style="list-style-type: none"> 1. Safety device are not in activated 2. Release valve damaged 	<ol style="list-style-type: none"> 1. Operate again 2. Repair or replace

IX. SCRAPING OF EQUIPMENT

Once the equipment is unusable and needs to be scrapped, please follow the local laws and regulations.

CLASSIC LIFT

Manual Part No.: 72203401

Revision Date: 2022/10